

P-LED EALP03SXDYA0-AM



Lead (Pb) Free Product - RoHS Compliant



Features

- High Flux Output.
- Designed for High Current Operation.
- Low Thermal Resistance.
- Low Profile.
- Packaged in Tubes for Use with Automatic Insertion Equipment.
- The product itself will remain within RoHS compliant version.
- Compliance with EU REACH.
- Compliance Halogen Free .(Br <900 ppm ,Cl <900 ppm , Br+Cl < 1500 ppm).

Applications

- Automotive Lighting
- Electronic Signs and Signals
- Special Lighting application

Device Selection Guide

| LED Part No. | Chip | | Resin Color |
|-----------------|----------|------------------|-------------|
| | Material | Emitted Color | |
| EALP03SXDYA0-AM | AlGaInP | Brilliant Yellow | Water Clear |

Absolute Maximum Ratings (Ta=25°C)

| Parameter | Symbol | Rating | Unit |
|---|-----------|--|------|
| Reverse Voltage | V_R | 5 | V |
| Continuous Forward Current | I_F | 70 | mA |
| Peak Forward Current (Duty 1/10 @1KHz) | I_{FP} | 160 | mA |
| Power Dissipation | P_d | 220 | mW |
| LED Junction Temperature | T_j | 115 | °C |
| Operating Temperature | T_{opr} | -40 ~ +100 | °C |
| Storage Temperature | T_{stg} | -40 ~ +100 | °C |
| Electrostatic Discharge | ESD | 2000 | V |
| Soldering Temperature(T=5 sec) | T_{sol} | Wave Soldering : 260 °C for 5 sec. Hand Soldering : 350 °C for 3 sec. | |

Electro-Optical Characteristics (Ta=25°C)

| Parameter | Symbol | Min. | Typ. | Max. | Unit | Condition |
|------------------------------|-----------------|-------|-------|-------|---------------|---------------------|
| Total Flux | Φ_v | 4500 | 6000 | 9000 | mlm | $I_F = 70\text{mA}$ |
| Peak Wavelength | λ_p | ----- | 591 | ----- | nm | $I_F = 70\text{mA}$ |
| Dominant Wavelength | λ_d | 586 | 589 | 594 | nm | $I_F = 70\text{mA}$ |
| Spectrum Radiation Bandwidth | $\Delta\lambda$ | ----- | 15 | ----- | nm | $I_F = 70\text{mA}$ |
| Viewing Angle | $2\theta_{1/2}$ | ----- | 55 | ----- | deg | $I_F = 70\text{mA}$ |
| Forward Voltage | V_F | 2.1 | 2.6 | 3.1 | V | $I_F = 70\text{mA}$ |
| Reverse Current | I_R | ----- | ----- | 10 | μA | $V_R = 5\text{V}$ |

Note:

1. Tolerance of Total Flux: $\pm 11\%$
2. Tolerance of Dominant Wavelength: $\pm 1\text{nm}$
3. Tolerance of Forward Voltage: $\pm 0.1\text{V}$

Bin Range of Dominant Wavelength (Ta=25°C)

| Bin | Min. | Max. | Unit | Condition |
|-----|------|------|------|-----------------------|
| 1 | 586 | 590 | nm | I _F =70 mA |
| 2 | 590 | 594 | | |

Note:

Tolerance of Dominant Wavelength: ±1nm

Bin Range of Forward Voltage (Ta=25°C)

| Bin | Min. | Max. | Unit | Condition |
|-----|------|------|------|----------------------|
| 3 | 2.1 | 2.3 | V | I _F =70mA |
| 4 | 2.3 | 2.5 | | |
| 5 | 2.5 | 2.7 | | |
| 6 | 2.7 | 2.9 | | |
| 7 | 2.9 | 3.1 | | |

Note:

Tolerance of Forward Voltage: ±0.1V

Bin Range of Total Flux (Ta=25°C)

| Bin | Min. | Max. | Unit | Condition |
|-----|------|------|------|----------------------|
| R | 4500 | 5650 | mlm | I _F =70mA |
| S | 5650 | 7150 | | |
| T | 7150 | 9000 | | |

Note:
Tolerance of Total Flux: ±11%

Typical Electro-Optical Characteristics Curves

Typical Curve of Spectral Distribution

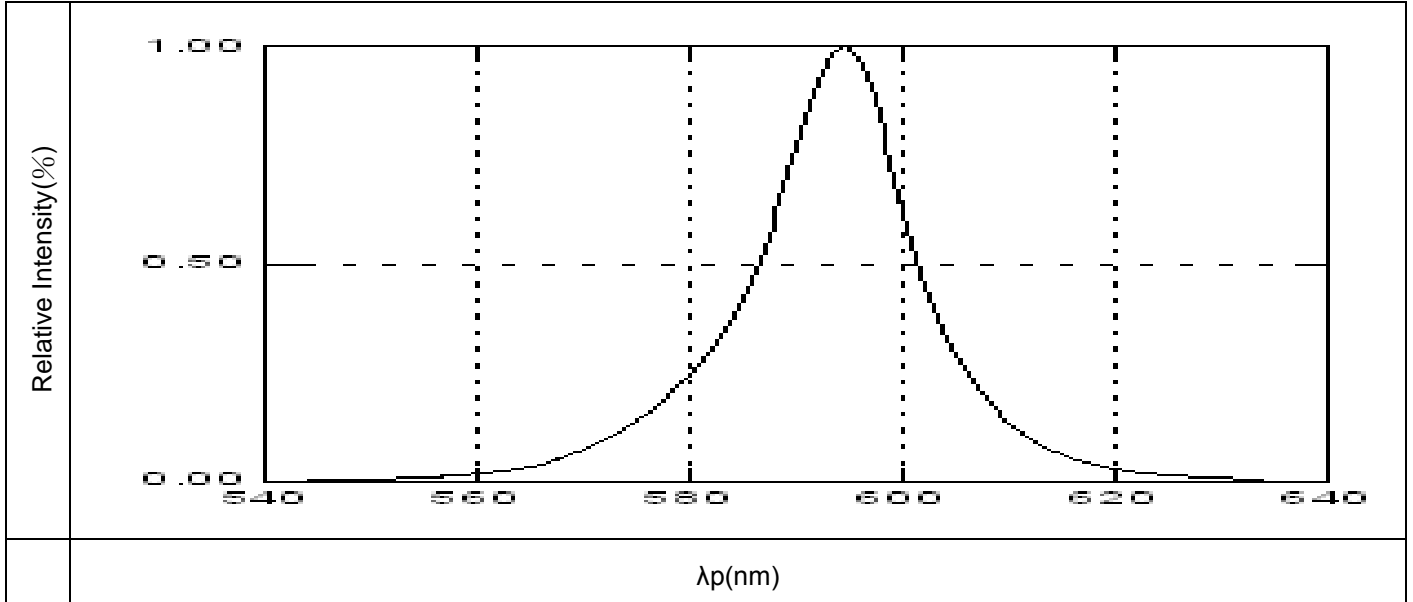

Note: $V(\lambda)$ =Standard eye response curve; $I_F = 70\text{mA}$

Diagram Characteristics of Radiation

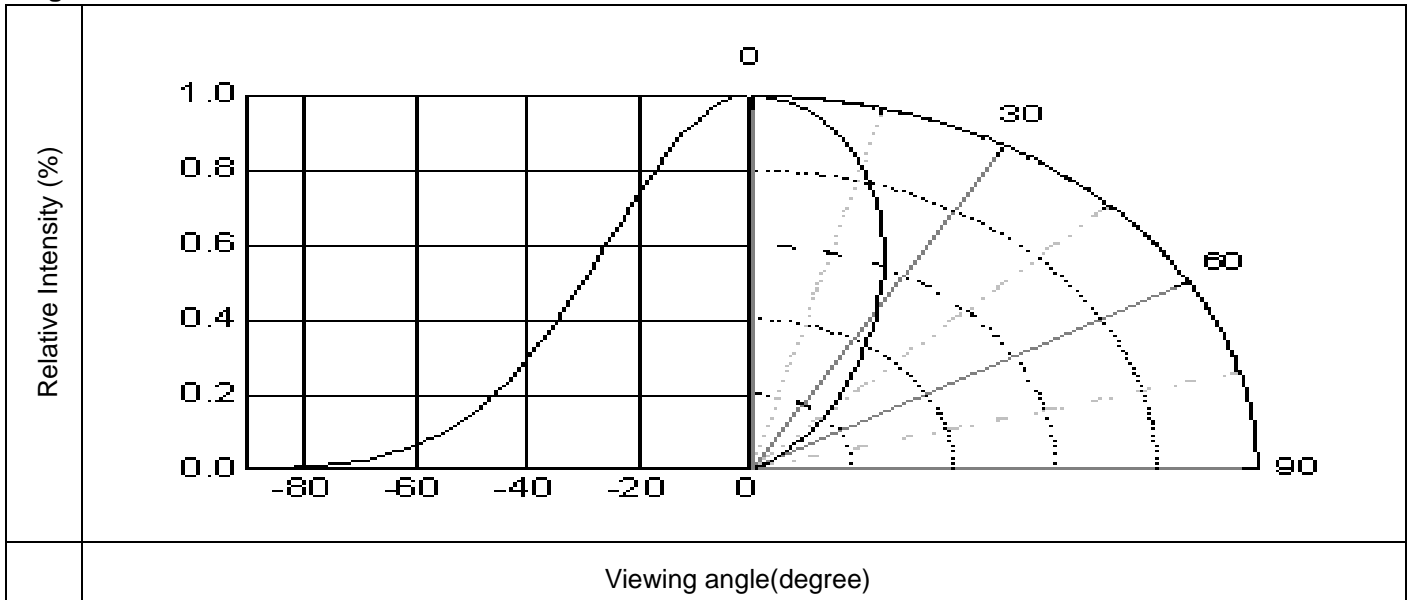

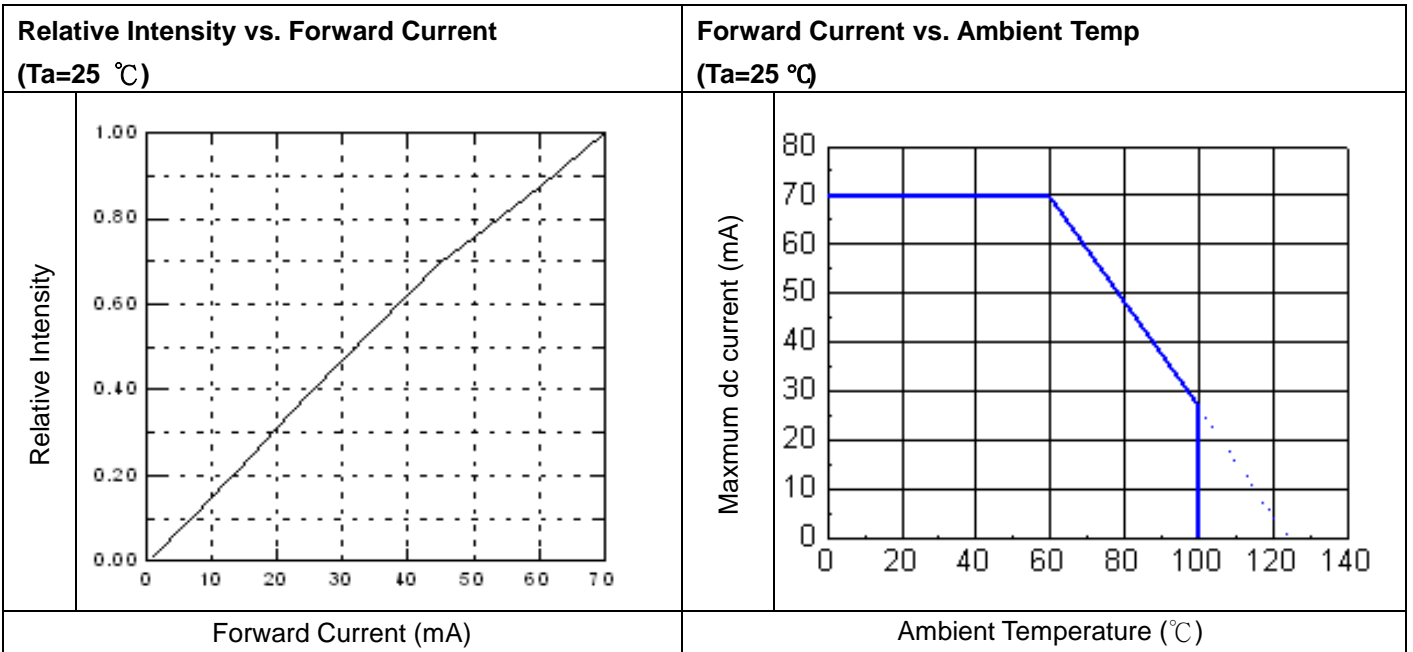
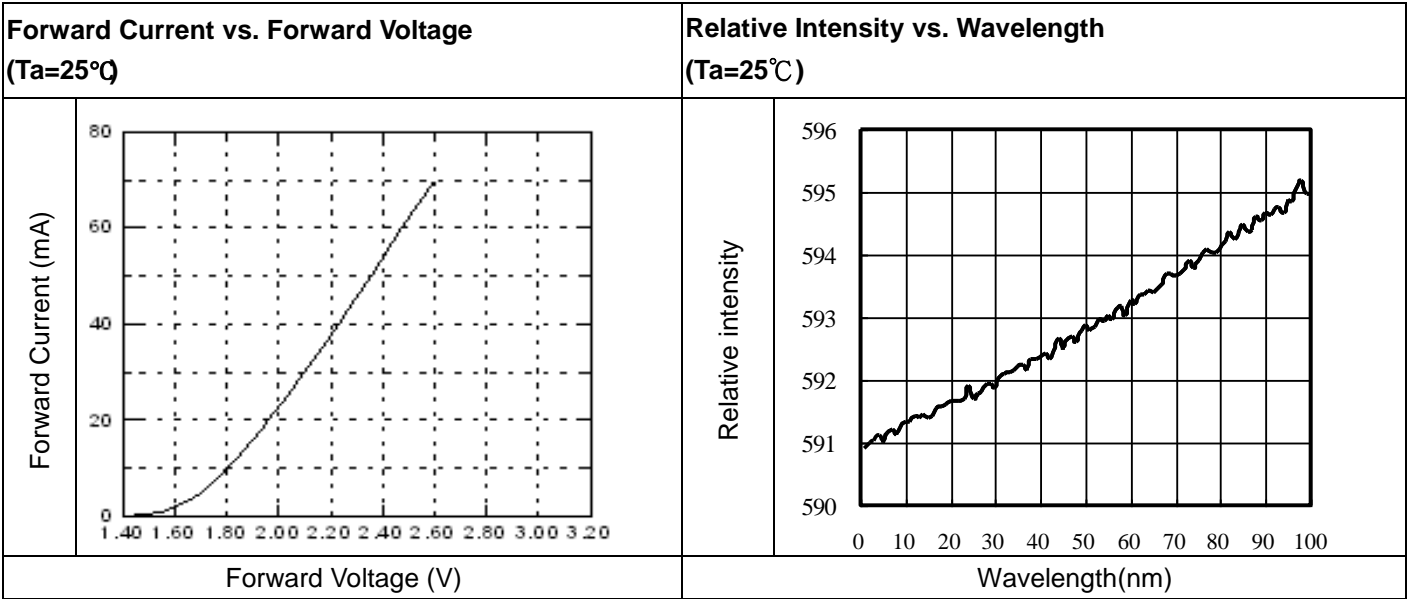

Package Dimensions

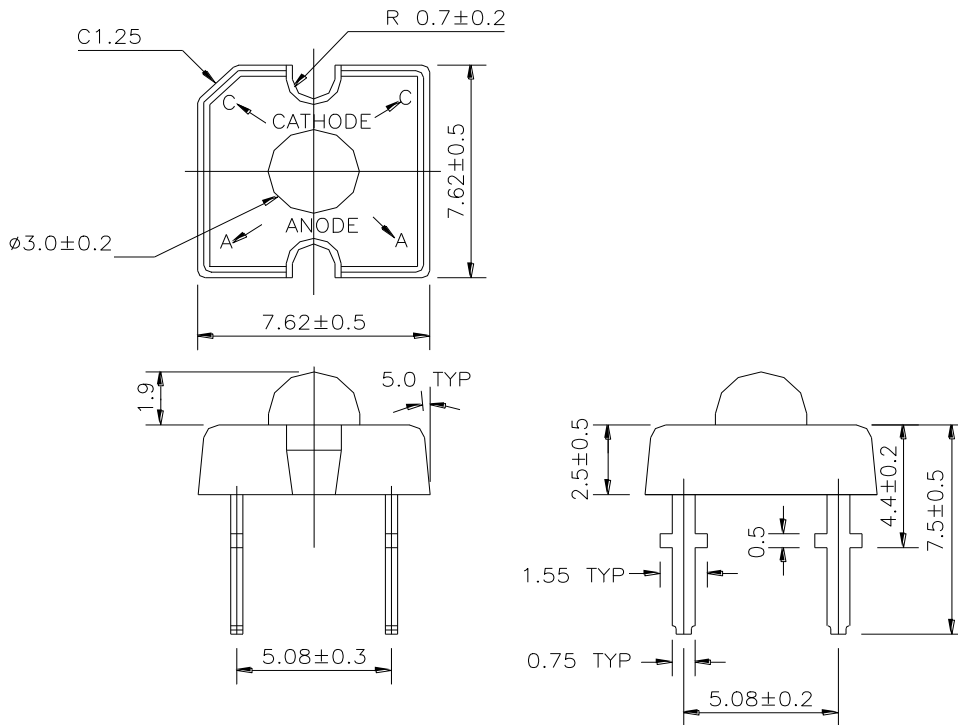

Note:

1. An epoxy meniscus may extend about 1.5mm(0.059") down the leads
2. Tolerances unless dimensions ± 0.25 mm
3. All dimensions are in millimeters

Inner and Outer Label Explanation

Outer Label Explanation



- CPN: Customer's Product Number
- P/N: Product Number
- QTY: Packing Quantity
- CAT: Rank of (VF)(Note*)(ΦV)
- NOTE: λ_d/CIE/Color temperature
- HUE/REF: Reference
- LOT No: Lot Number

Inner Label Explanation



- P/N: Product Number
- QTY: Packing Quantity
- CAT: Rank of (VF)(Note*)(ΦV)
- NOTE: λ_d/CIE/Color temperature
- LOT No: Lot Number

Antistatic Packing Materials Tube
Antistatic Packing Materials Tube
Materials Tube

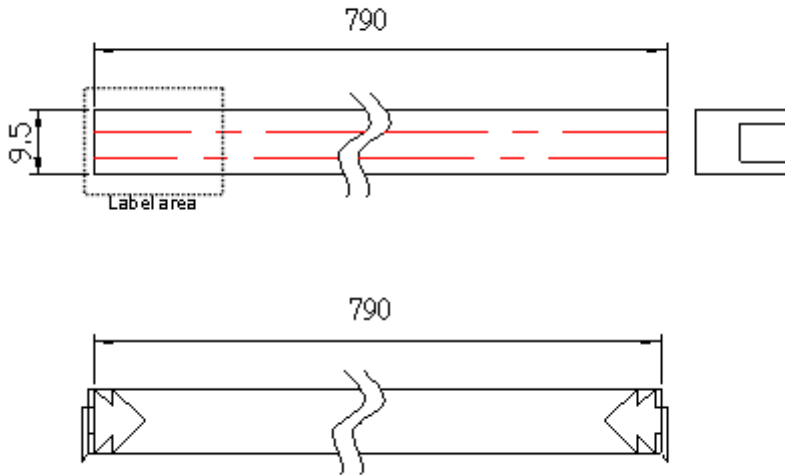

Note:

1. Tolerances unless mentioned $\pm 2.0\text{mm}$.
2. Unit = mm

Standard Boxes

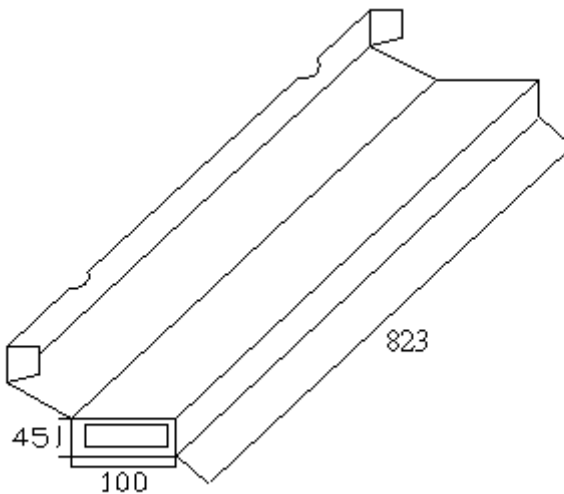

Note:

1. Tolerances unless mentioned $\pm 3.0\text{mm}$.
2. Unit = mm

Precautions for use

1. Lead Forming

- During lead formation, the leads should be bent at a point at least 3mm from the base of the epoxy bulb.
- Lead forming should be done before soldering.
- Avoid stressing the LED package during leads forming. The stress to the base may damage the LED's characteristics or it may break the LEDs.
- Cut the LED leadframes at room temperature. Cutting the leadframes at high temperatures may cause failure of the LEDs.
- When mounting the LEDs onto a PCB, the PCB holes must be aligned exactly with the lead position of the LED. If the LEDs are mounted with stress at the leads, it causes deterioration of the epoxy resin and this will degrade the LEDs.

2. Storage

- The LEDs should be stored at 30°C or less and 60%RH or less after being shipped from Everlight Americas and the storage life limits are 3 months. If the LEDs are stored for 3 months or more, they can be stored for a year in a sealed container with a nitrogen atmosphere and moisture absorbent material.
- Please avoid rapid transitions in ambient temperature, especially, in high humidity environments where condensation can occur.

3. Soldering

- Careful attention should be paid during soldering. Solder the LED no lower than 1.6mm from the base of stopper is recommended.
- Avoiding applying any stress to the lead frame while the LEDs are at high temperature particularly when soldering.
- Recommended soldering conditions:

| Hand Soldering | | DIP Soldering | |
|----------------------|--|---------------|--|
| Temp. at tip of iron | 300°C Max. (30W Max.) | Preheat temp. | 100°C Max. (60 sec Max.) |
| Soldering time | 3 sec Max. | Bath temp. | 260 Max. |
| Distance | No lower than 1.6mm from the base of stopper | Bath time. | 5 sec Max. |
| | | Distance | No lower than 1.6mm from the base of stopper |

■ Recommended soldering profile

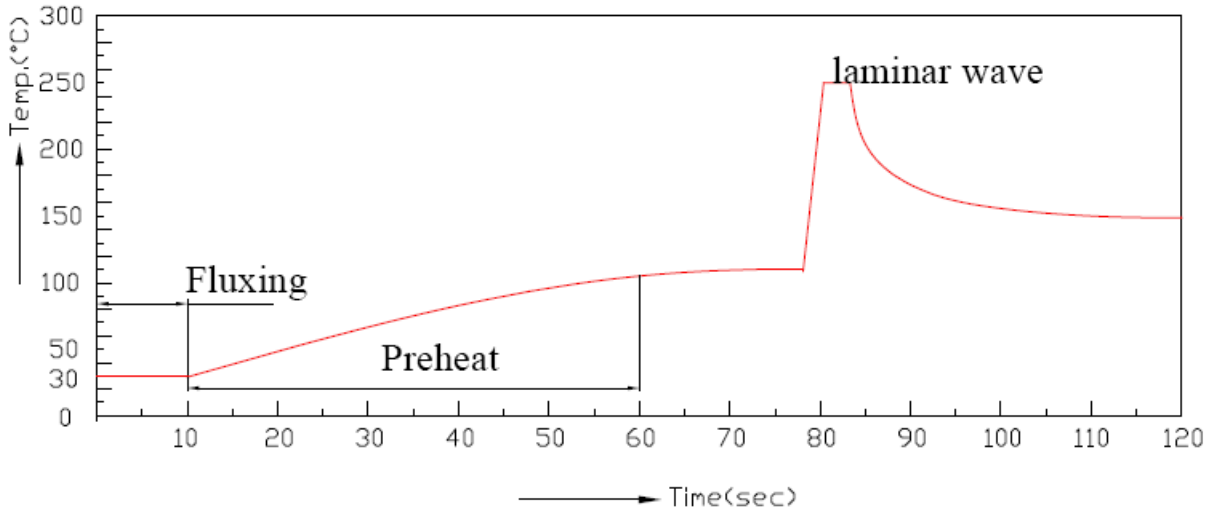

- To avoid any stress to the lead frame while the LEDs are at high temperature particularly when soldering.
- Dip or hand soldering should not be done more than one time.
- The len of LEDs should be protected from mechanical shock or vibration until return to room temperature after soldering.
- Cooling rapidly is not recommended after cold down from peak temperature.
- Dipping parameters must be set and maintain according to recommended range.

4. Cleaning

- Cleaning with isopropyl alcohol should not more than one minute and dry it in room temperature.
- Ultrasonic cleaning is prohibited which may damage the LEDs.

5. Thermal Management

Sufficient thermal management must be implemented. Otherwise, the junction temperature of the die might be over the limit at high current driving condition and LEDs' lifetime might be decreases dramatically.

6. ESD (Electrostatic Discharge)

- The products are sensitive to static electricity or surge voltage. ESD can damage a die and its reliability. When handling the products, the following measures against electrostatic discharge are strongly recommended:
 - Eliminating the charge
 - Grounded wrist strap, ESD footwear, clothes, and floors
 - Grounded workstation equipment and tools
 - ESD table/shelf mat made of conductive materials
- Proper grounding is required for all devices, equipment, and machinery used in product assembly. Surge protection should be considered when designing of commercial products.
- If tools or equipment contain insulating materials such as glass or plastic,

the following measures against electrostatic discharge are strongly recommended:

- Dissipating static charge with conductive materials
- Preventing charge generation with moisture
- Neutralizing the charge with ionizers

7. Directions for use

- The LEDs should be operated with forward bias. The driving circuit must be designed so that the LEDs are not subjected to forward or reverse voltage while it is off. If reverse voltage is continuously applied to the LEDs, it may cause migration resulting in LED damage

8. Other

- EVERLIGHT AMERICAS assumes no responsibility for any damage resulting from use of the product which does not comply with the absolute maximum ratings and the instructions included in these specification sheets.
- These specification sheets include all the contents are protected under copyright of EVERLIGHT AMERICAS Corporation. Please don't reproduce or cause anyone to reproduce without EVERLIGHT AMERICAS's permission.

Application Restrictions

High reliability applications such as military/aerospace, automotive safety/security systems, and medical equipment may require different product. If you have any concerns, please contact Everlight before using this product in your application. This specification guarantees the quality and performance of the product as an individual component. Do not use this product beyond the specification described in this document.

Revision History

| Rev. | Modified date | File modified contents |
|------|---------------|---------------------------|
| 1 | 2012-4-13 | New Spec. |
| 2 | 2014-2-18 | Modify the version format |