

SMD ■ SMD- Full Color Top View LEDs EAPL3527RGBA0



Features

- P-LCC-4 package.
- White package and black surface.
- Optical indicator.
- Ideal for backlight and light pipe application.
- Wide viewing angle.
- Suitable for vapor-phase reflow, Infrared reflow and wave solder processes.
- Computable with automatic placement equipment.
- Available on tape and reel (8mm Tape).
- Pb-free.
- The product itself will remain within RoHS compliant version.
- Compliance with EU REACH.
- Compliance Halogen Free .(Br <900 ppm ,Cl <900 ppm , Br+Cl < 1500 ppm).
- Precondition: Bases on JEDEC J-STD 020D Level 3

Description

The EAPL3527RGBA0 series is available in soft orange, green, blue, and yellow. Due to the package design, the LED has wide viewing angle and optimized light coupling by inter reflector. This feature makes the LED ideal for light pipe application. The low current requirement makes this device ideal for portable equipment or any other application where power is at a premium.

Applications

- Telecommunication: indicator and backlighting in telephone and fax.
- Flat backlight for LCD's, switches and symbols.
- Light pipe application.
- General use.

Device Selection Guide

Chip Materials	Emitted Color	Resin Color
AlGaInP	Brilliant Red	Water Clear
InGaN	Brilliant Green	
InGaN	Blue	

Absolute Maximum Ratings (Ta=25°C)

Parameter	Symbol	Rating	Unit	
Reverse Voltage	V_R	5	V	
Forward Current	I_F	RS	50	mA
		GH	30	
		BH	30	
Peak Forward Current (Duty 1/10 @1KHz)	I_{FP}	RS	100	mA
		GH	100	
		BH	100	
Power Dissipation	P_d	RS	120	mW
		GH	110	
		BH	110	
Total Power Dissipation	P_{tot}	340	mW	
Operating Temperature	T_{opr}	-40 ~ +85	°C	
Storage Temperature	T_{stg}	-40 ~ +90	°C	
ESD	ESD_{HBM}	RS	2000	V
		GH	1000	
		BH	1000	
Soldering Temperature	T_{sol}	Reflow Soldering : 260 °C for 10 sec. Hand Soldering : 350 °C for 3 sec.		

Electro-Optical Characteristics (Ta=25°C)

Parameter	Symbol	Code	Min.	Typ.	Max.	Unit	Condition
Luminous Intensity	I _v	RS	565	---	1120	mcd	I _F =20mA
		GH	900	---	1420		
		BH	225	---	450		
Viewing Angle	2θ _{1/2}		---	120	---	deg	I _F =20mA
Peak Wavelength	λ _p	RS	---	632	---	nm	I _F =20mA
		GH	---	518	---		
		BH	---	468	---		
Dominant Wavelength	λ _d	RS	617.5	---	627	nm	I _F =20mA
		GH	520	---	535		
		BH	465	---	470		
Spectrum Radiation Bandwidth	Δλ	RS	---	25	---	nm	I _F =20mA
		GH	---	35	---		
		BH	---	35	---		
Forward Voltage	V _F	RS	---	2.0	2.4	V	I _F =20mA
		GH	---	3.5	4.0		
		BH	---	3.5	4.0		
Reverse Current	I _R		---	---	10	μA	V _R =5V

Note:

1. Tolerance of Luminous Intensity: ±10%
2. Tolerance of Dominant Wavelength: ±1nm
3. Tolerance of Forward Voltage: ±0.1V

Bin Range of Luminous Intensity

Chip	Bin Code	Min.	Max.	Unit	Condition
RS	U2	565	715	mcd	I _F =20mA
	V1	715	900		
	V2	900	1120		
GH	V2	900	1120		
	W1	1120	1420		
BH	S2	225	285		
	T1	285	360		
	T2	360	450		

Note:
Tolerance of Luminous Intensity: ±10%

Bin Range of Dominant Wavelength

Chip	Bin Code	Min.	Max.	Unit	Condition
RS	1	617.0	622.0	nm	I _F =20mA
	2	622.0	627.0		
GH	X	520	525		
	Y	525	530		
	Z	530	535		
BH	X	465.0	470.0		

Note:
Tolerance of Dominant Wavelength: ±1nm

Typical Electro-Optical Characteristics Curves (RS)

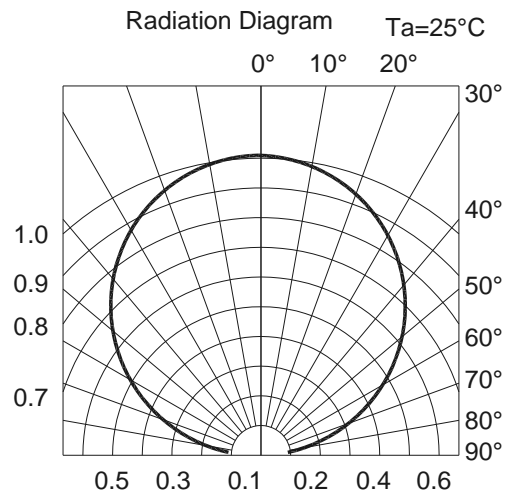
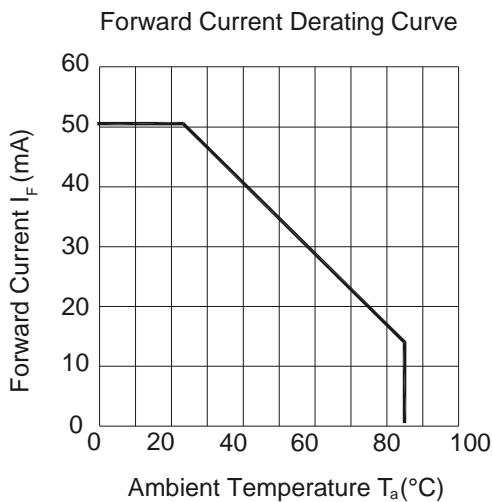
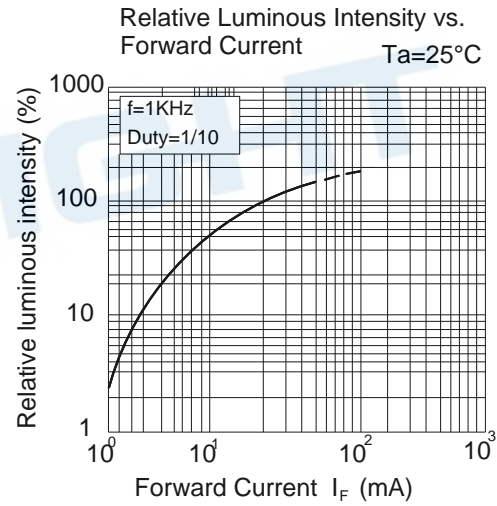
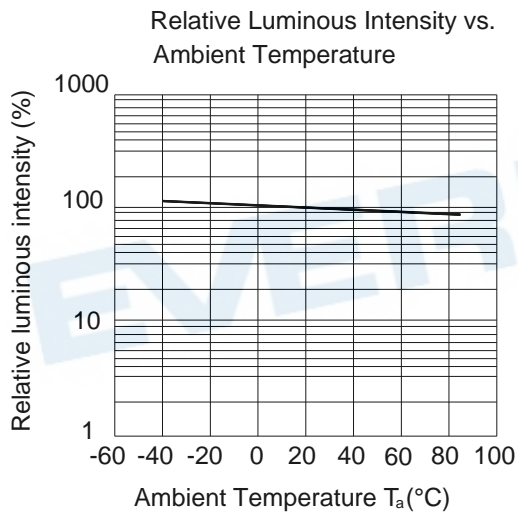
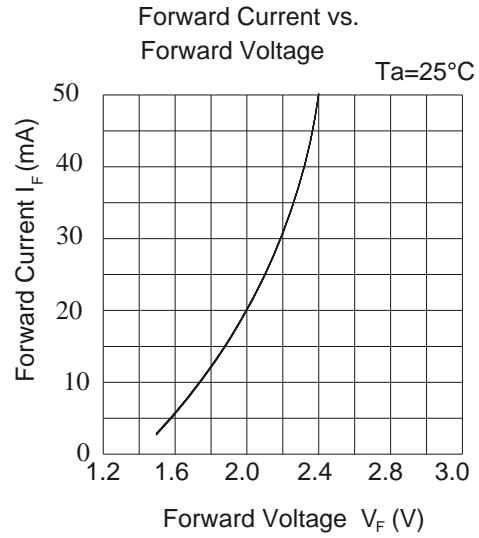
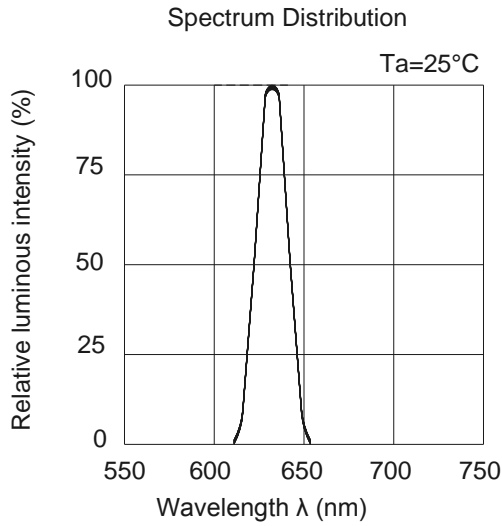

Typical Electro-Optical Characteristics Curves (GH)

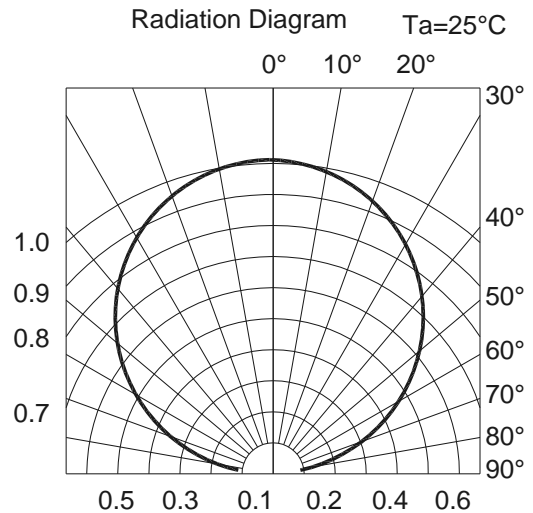
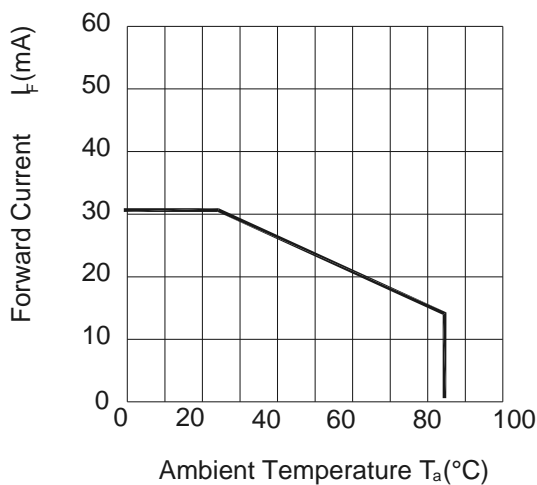
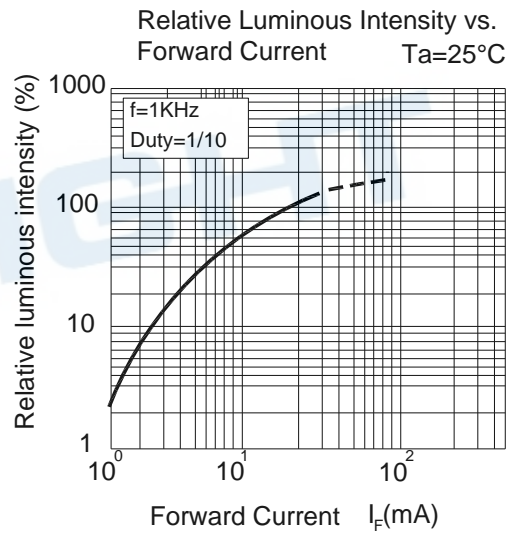
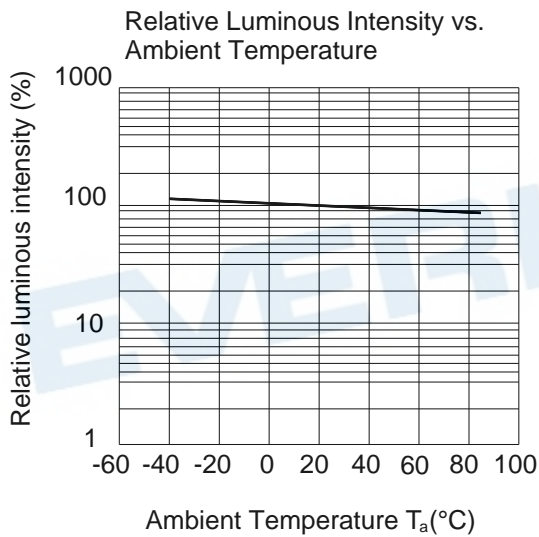
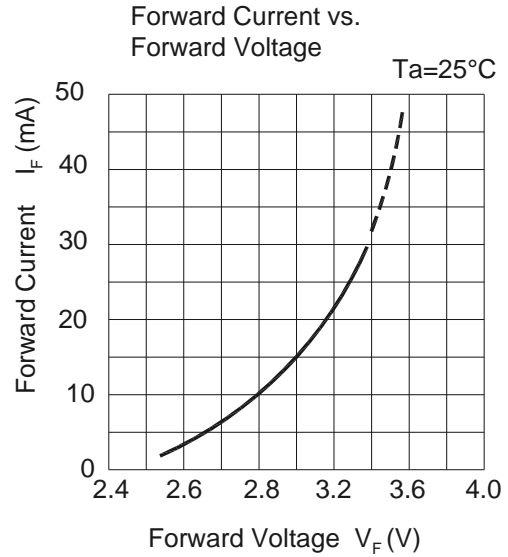
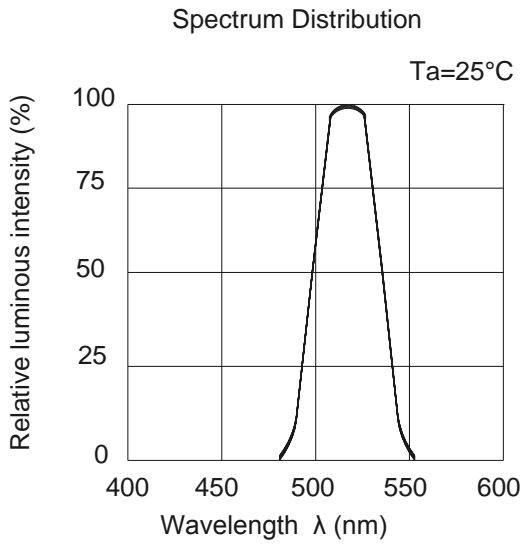

Typical Electro-Optical Characteristics Curves (BH)

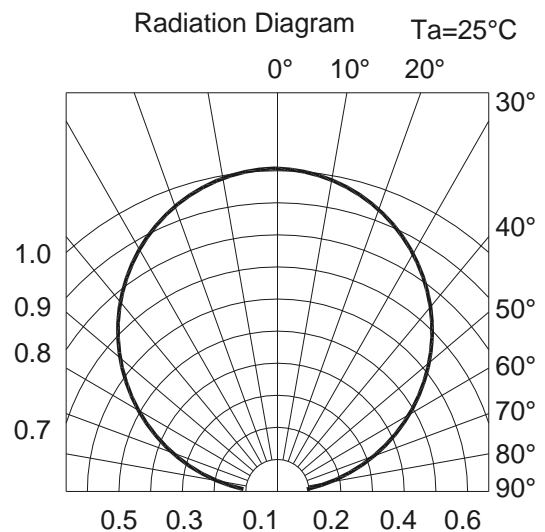
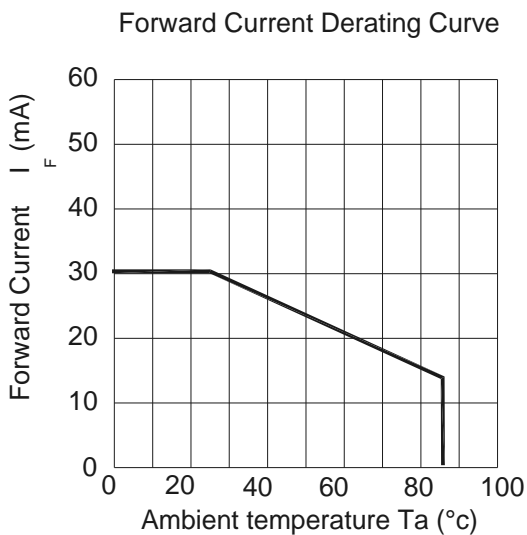
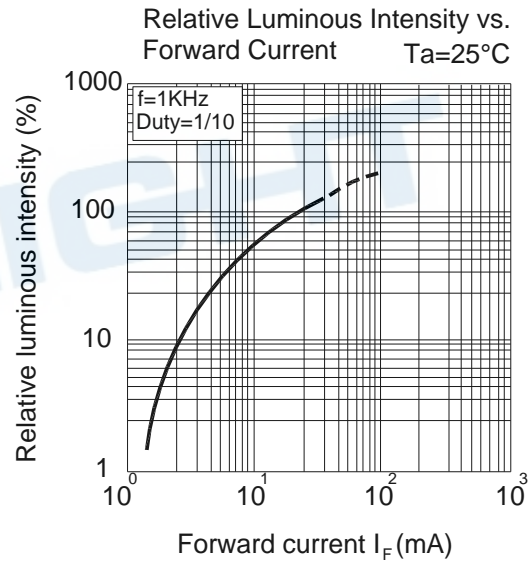
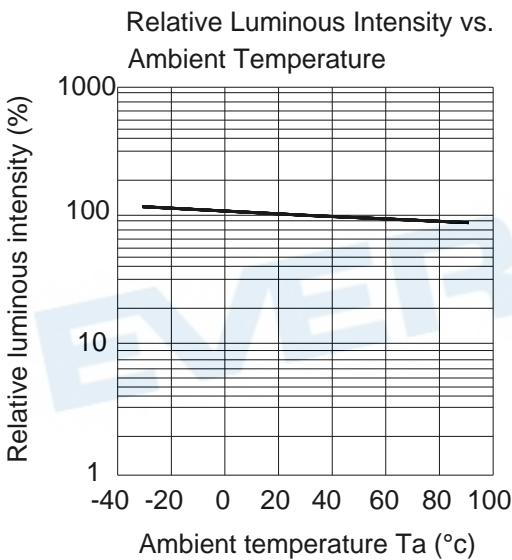
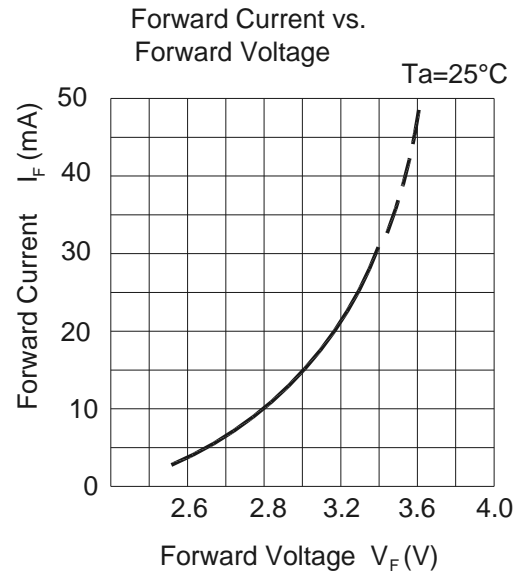
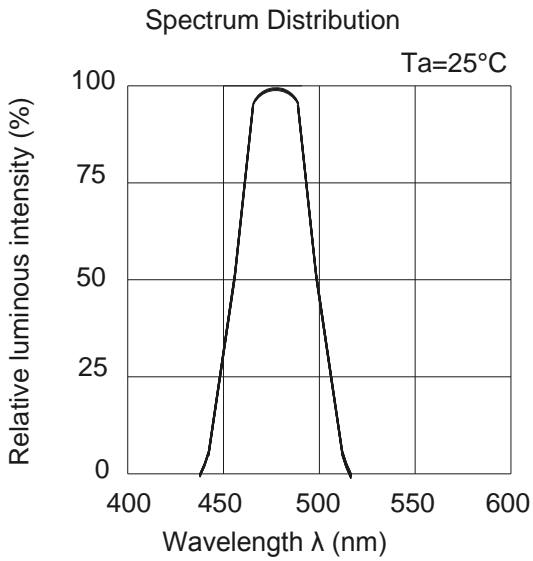

Package Dimension

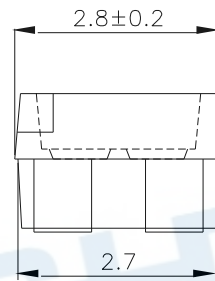
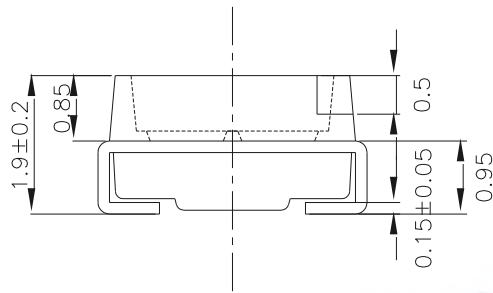
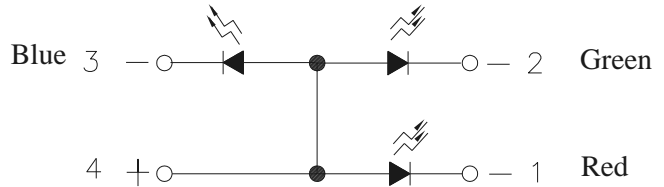
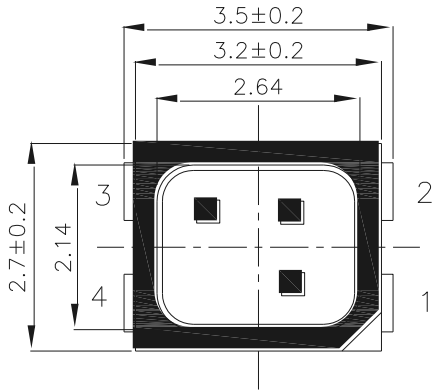

Recommended Solder Pad

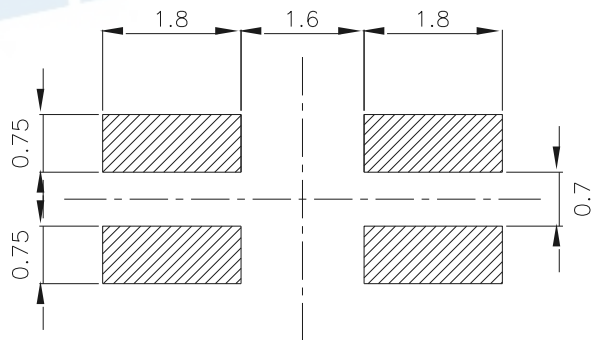
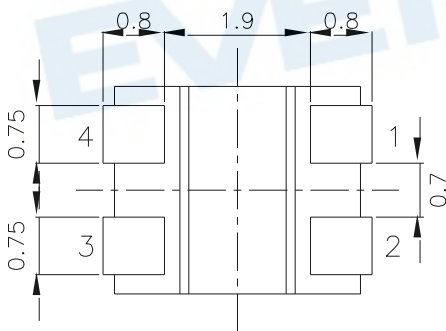

Note: Tolerances unless mentioned ±0.1mm. Unit = mm

Moisture Resistant Packing Materials

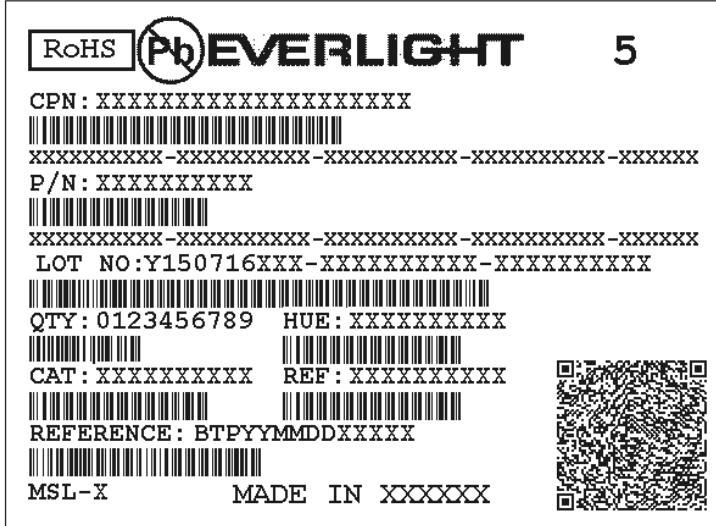

- CPN: Customer's Product Number
- P/N: Product Number
- QTY: Packing Quantity
- CAT: Luminous Intensity Rank
- HUE: Dom. Wavelength Rank
- REF: Forward Voltage Rank
- LOT No: Lot Number

Reel Dimensions

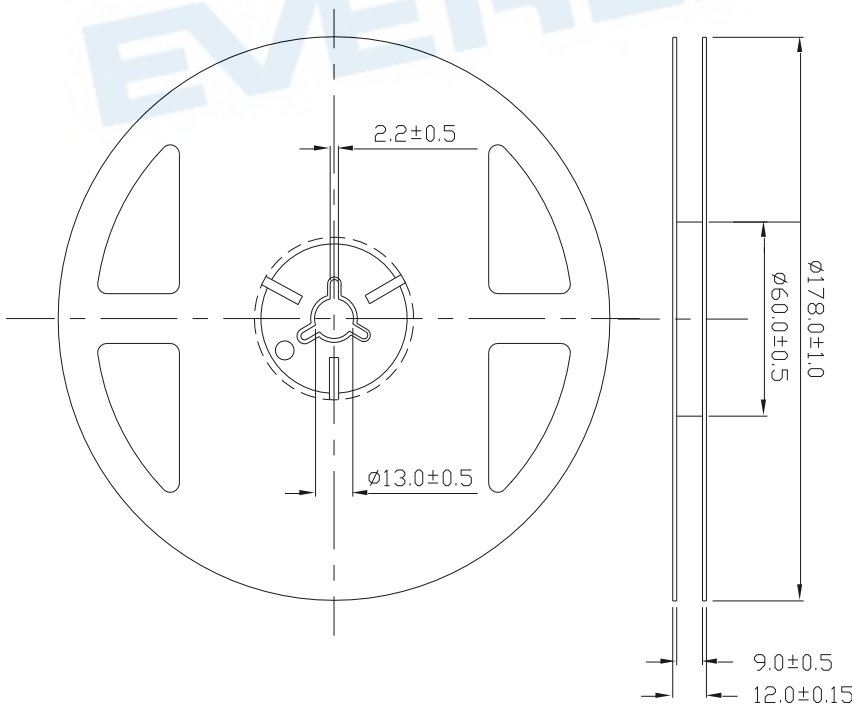

Note: Tolerances unless dimension ± 0.1 mm; Unit = mm

Carrier Tape Dimensions:

Minimum packing amount is 1000 pcs per reel

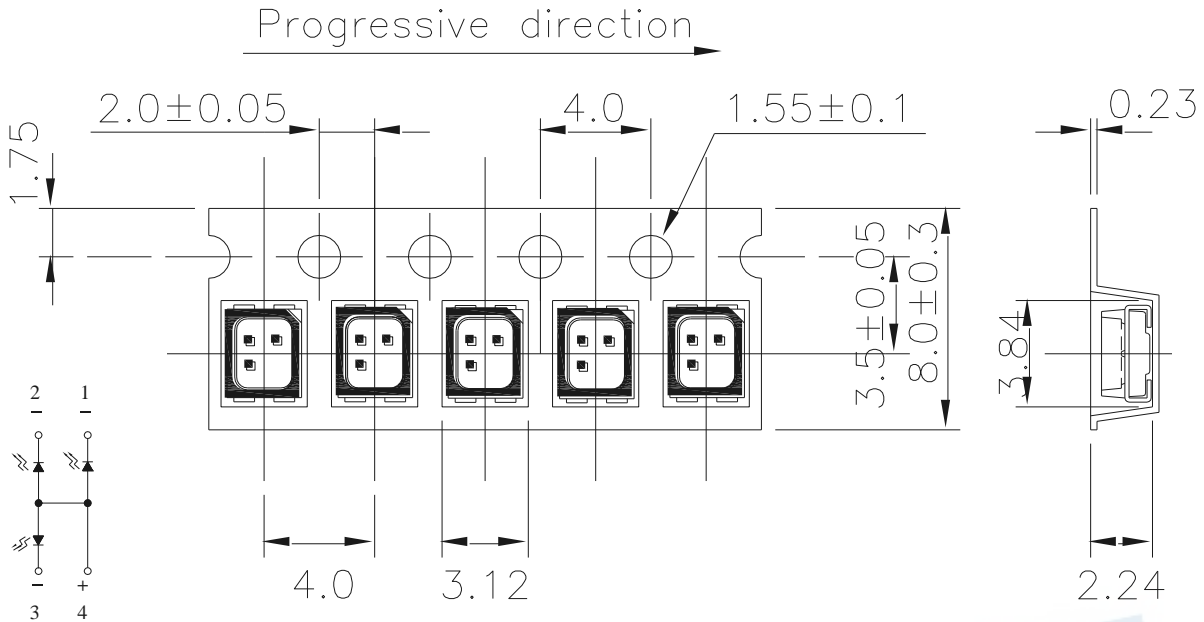

Note: Tolerances unless mentioned ±0.1mm. Unit = mm

Moisture Resistant Packing Process

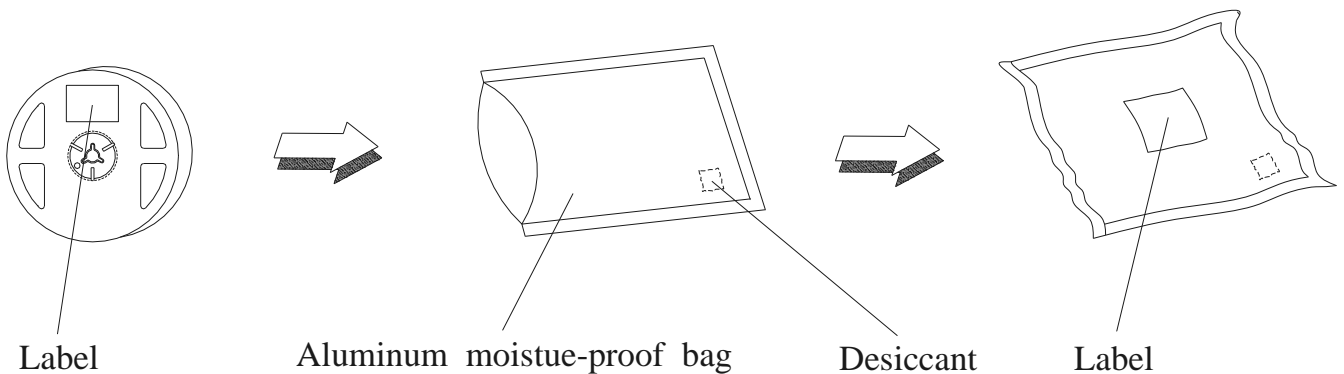

Note: Tolerances unless mentioned ±0.1mm. Unit = mm

Precautions for Use

1. Over-current-proof

1.1 Customer must apply resistors for protection, otherwise slight voltage shift will cause big current change (Burn out will happen).

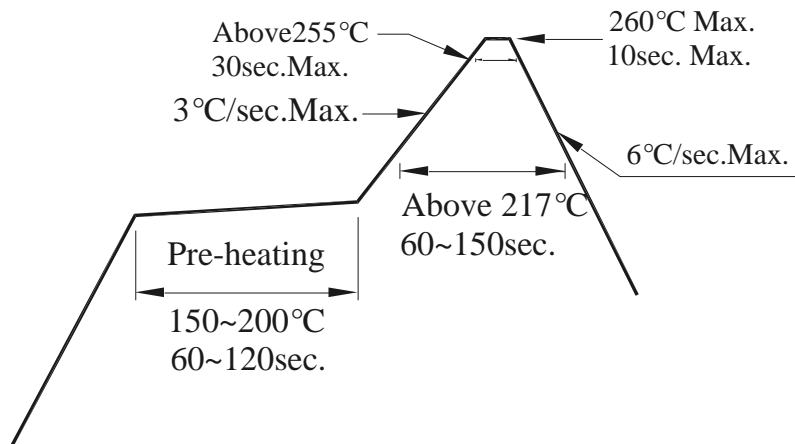

2. Storage

- 2.1 Moisture proof bag should only be opened immediately prior to usage.
- 2.2 Environment should be less than 30°C and 60% RH when moisture proof bag is opened.
- 2.3 After opening the package MSL Conditions stated on page 1 of this spec should not be exceeded.
- 2.4 If the moisture sensitivity card indicates higher than acceptable moisture, the component should be baked at min. 60deg +/-5deg for 24 hours.

3. Soldering Condition

- 3.1 Pb-free solder temperature profile
- 3.2 Reflow soldering should not be done more than two times.
- 3.3 When soldering, do not put stress on the LEDs during heating.
- 3.4 After soldering, do not warp the circuit board.

4. Soldering Iron

Each terminal is to go to the tip of soldering iron temperature less than 350°C for 3 seconds within once in less than the soldering iron capacity 25W. Leave two seconds and more intervals, and do soldering of each terminal. Be careful because the damage of the product is often started at the time of the hand solder.

5. Repairing

Repair should not be done after the LEDs have been soldered. When repairing is unavoidable, a double-head soldering iron should be used (as below figure). It should be confirmed beforehand whether the characteristics of the LEDs will or will not be damaged by repairing.

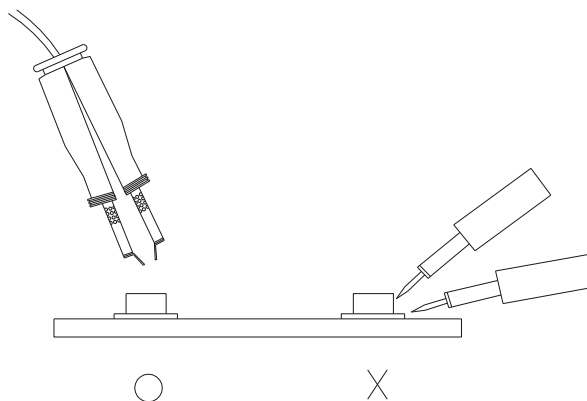

DISCLAIMER

1. EVERLIGHT reserves the right(s) on the adjustment of product material mix for the specification.
2. The product meets EVERLIGHT published specification for a period of twelve (12) months from date of shipment.
3. The graphs shown in this datasheet are representing typical data only and do not show guaranteed values.
4. When using this product, please observe the absolute maximum ratings and the instructions for using outlined in these specification sheets. EVERLIGHT assumes no responsibility for any damage resulting from the use of the product which does not comply with the absolute maximum ratings and the instructions included in these specification sheets.
5. These specification sheets include materials protected under copyright of EVERLIGHT. Reproduction in any form is prohibited without obtaining EVERLIGHT's prior consent.
6. This product is not intended to be used for military, aircraft, automotive, medical, life sustaining or life saving applications or any other application which can result in human injury or death. Please contact authorized Everlight sales agent for special application request.

EVERLIGHT