

EL Mini TOP VIEW LED 65-11-IB0100L-AM



Features

- Black Package : Ice Blue LED with PLCC 2 black package
- Emitted Color : Ice Blue
- Typ. Luminance Intensity : 355 mcd @ 10mA
- Typ. Luminous Flux : 1 lm @ 10mA
- Viewing angle : 120°
- ESD; up to 8KV
- MSL : 2a
- Preconditioning : According to JEDEC J-STD 020D Level 2a
- Qualifications; According to AEC-Q101
- Compliance with RoHS and REACH

Applications

- Automotive Interior Lighting , Dashboard, Switch, Reading lamp, Audio and Car Infotainment....etc
- Backlight: LCD, switches, symbol, mobile phone and illuminated advertising.
- Optical indicator.
- General applications.

Contents

Characteristics	3
Absolute Maximum Ratings	4
Characteristics Graph	5
Binning Information	9
Part Number	16
Ordering Information	17
Mechanical Dimension	18
Recommended Soldering Pad	19
Reflow Soldering Profile	19
Packaging Information	20
Precaution for Use	22

1. Characteristics

Parameter		Symbol	Min.	Typ.	Max.	Unit	Condition
Forward Current	Ice Blue	I_F	2	10	20	mA	---
Luminous Intensity	Ice Blue	Φ_v	140	355	560	mcd	$I_F=10\text{mA}$
Forward Voltage	Ice Blue	V_F	2.75	3.1	3.75	V	$I_F=10\text{mA}$
Viewing Angle	Ice Blue	φ	---	120	---	deg	$I_F=10\text{mA}$
Color	Ice Blue	CIE x	---	0.18	---	---	$I_F=10\text{mA}$
Color	Ice Blue	CIE y	---	0.23	---	---	$I_F=10\text{mA}$
Thermal Resistance (Junction to Solder)	Real	$R_{th\ JS\ real}$	---	120	---	K/W	$I_F=10\text{mA}$
	Electrical	$R_{th\ JS\ el}$	---	95	---		

Notes:

1. Luminous Intensity measurement tolerance: $\pm 8\%$.
2. The data of Luminous Intensity measured at thermal pad= 25°C .
3. Typical luminous Intensity or light output performance is operated within the condition guided by this datasheet.
4. Forward voltage measurement tolerance: $\pm 0.1\text{V}$.
5. The V_F range shown in the table above indicates 99% output.
6. Tolerance of Chromaticity Coordinates x,y: ± 0.005 .

2. Absolute Maximum Ratings

Parameter	Symbol	Ratings	Unit
Power Dissipation	P_d	76	mW
Forward Current	I_F	2~20	mA
Reverse Voltage	V_R	Not designed for reverse operation	V
Junction Temperature	T_J	125	°C
Operating Temperature	T_{opr}	-40 ~ +110	°C
Storage Temperature	T_{stg}	-40 ~ +110	°C
ESD Sensitivity (R=1.5kΩ, C= 100pF)	ESD_{HBM}	8K	V
Soldering Temperature	Reflow	260°C for 30sec	°C

3.Characteristics Graph

Wavelength Characteristics Relative Spectral Distribution
@ Ts = 25°C, If=10mA, RH=30%

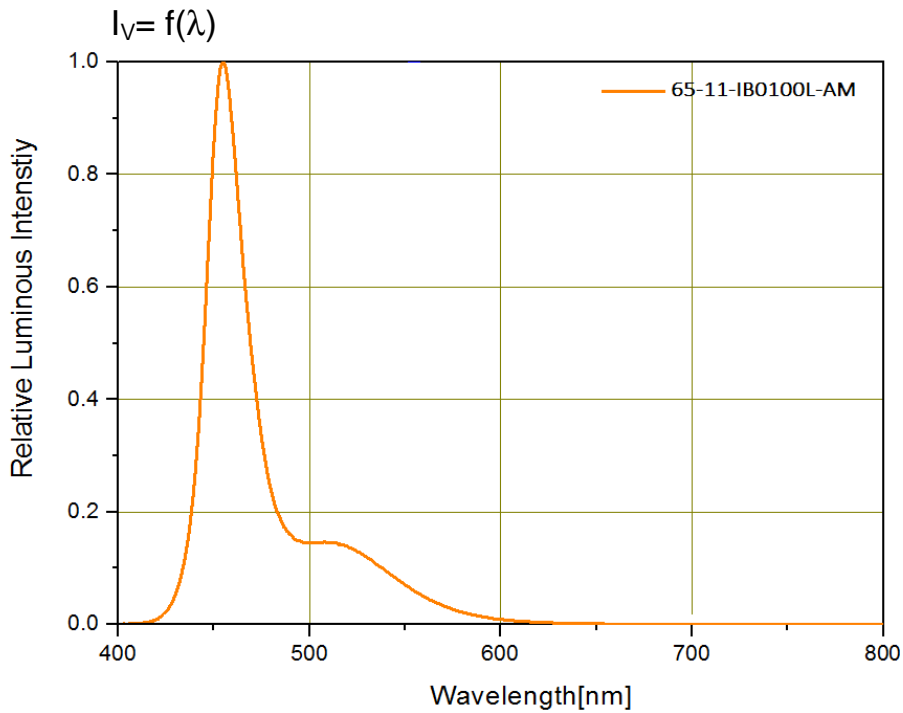

Typical Diagram Characteristics of Radiation

$$\Phi_V / \Phi_V(0^\circ) = f(\varphi)$$

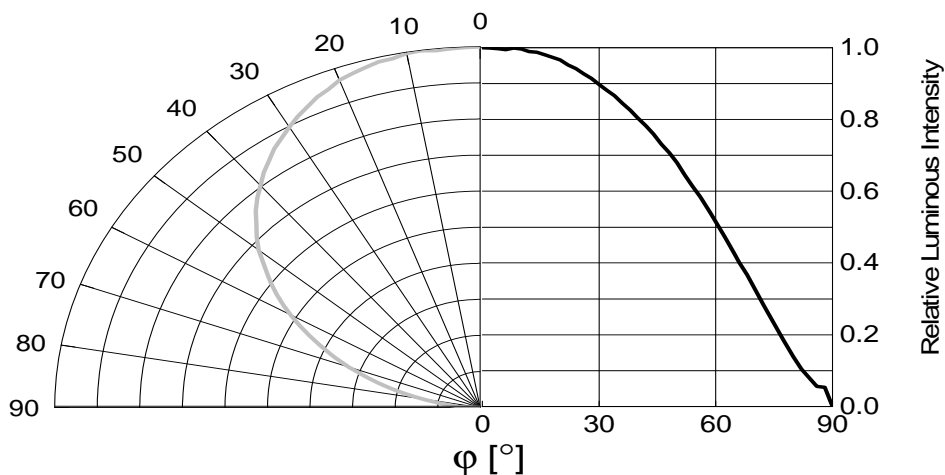

Notes:

1. φ is the off axis angle from lamp centerline where the luminous intensity is 1/2 of the peak value.

Forward Current vs. Forward Voltage

@ Ts = 25°C

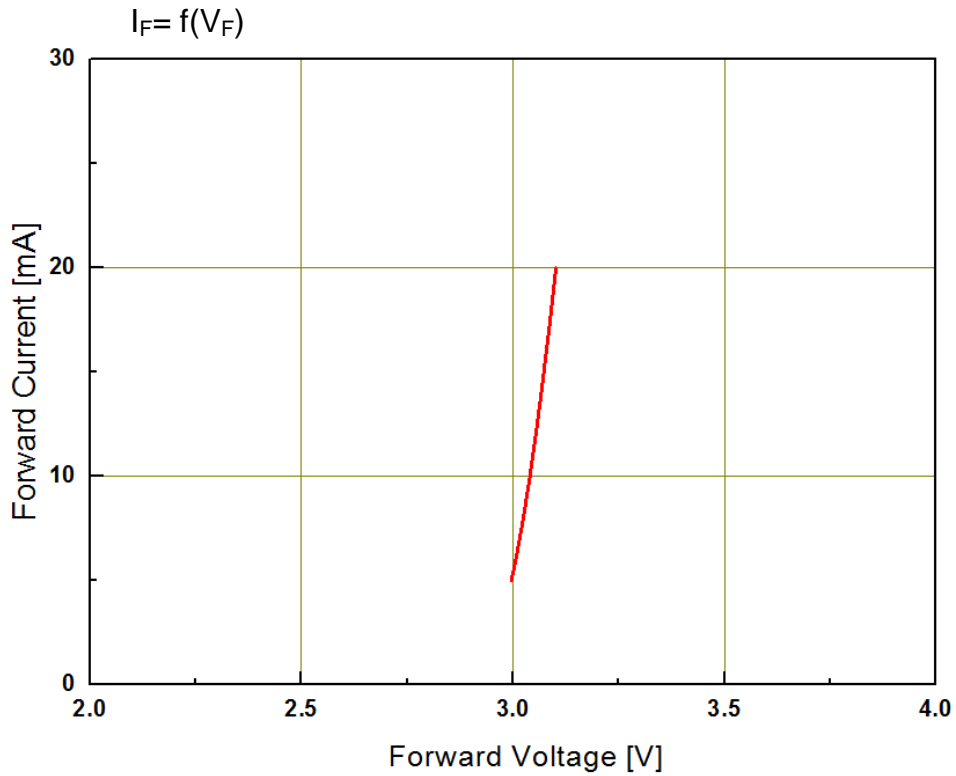

Luminous vs. Forward Current

@ Ts = 25°C

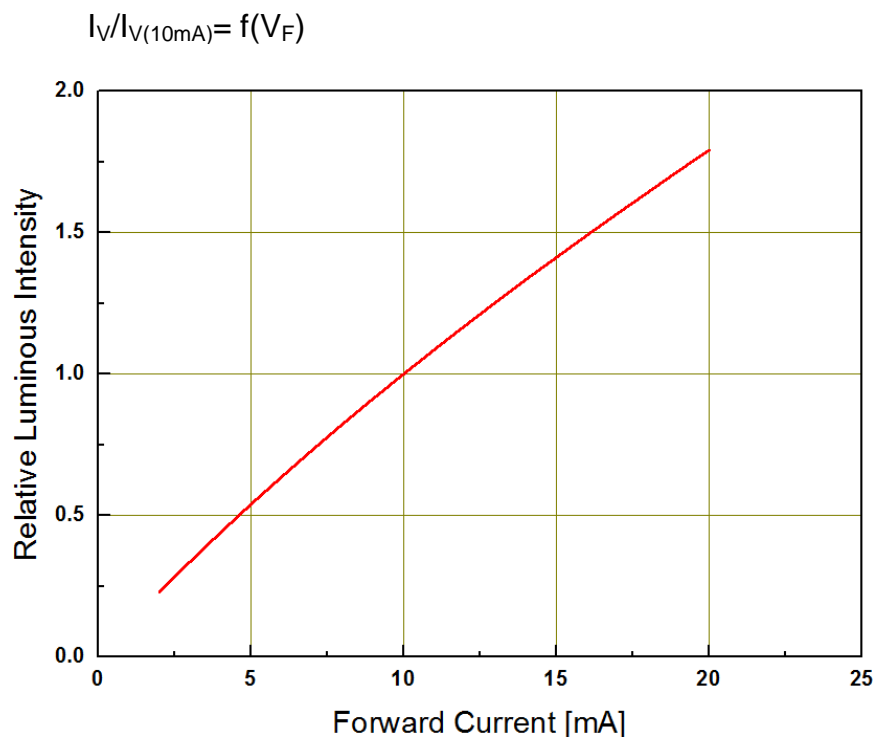

Chromaticity Coordinates Shift vs. Forward Current @ $T_s = 25^\circ\text{C}$

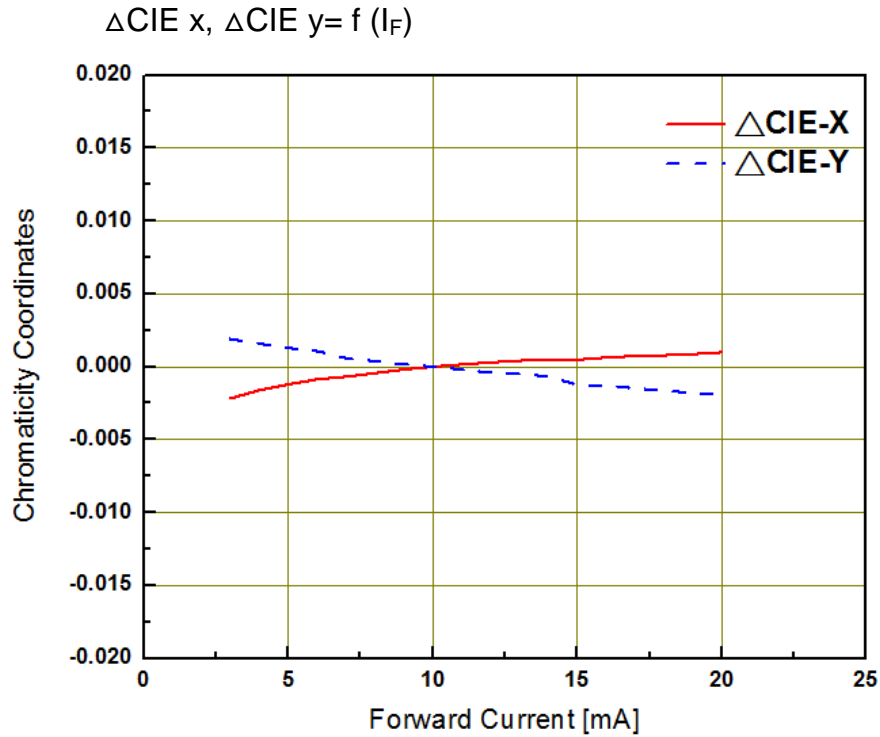

Relative Forward Voltage vs. Junction Temperature @ $I_F = 10\text{mA}$

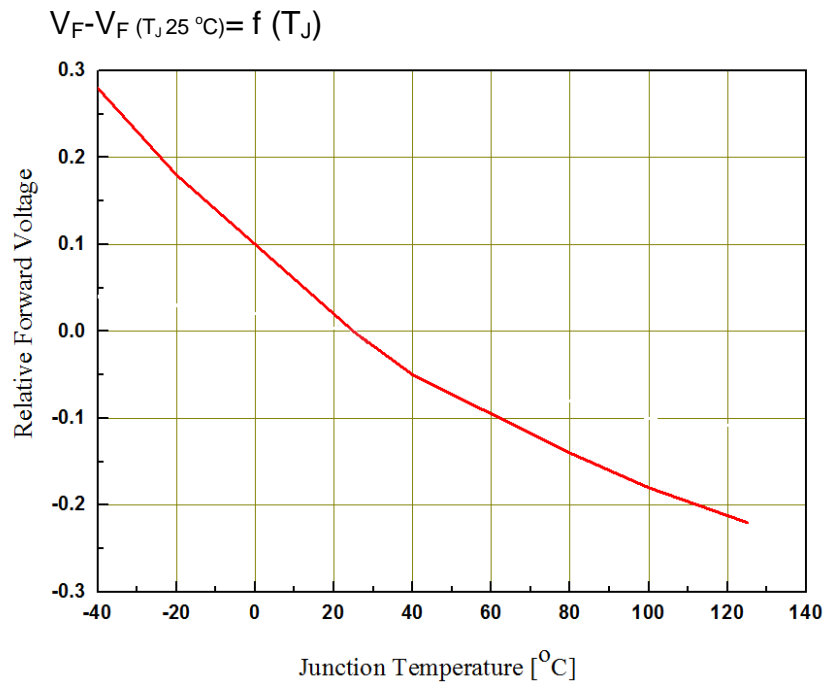

Relative Luminous Intensity vs. Junction Temperature

@ $I_F=10\text{mA}$

$$I_V/I_V(T_J 25^\circ\text{C}) = f(T_J)$$

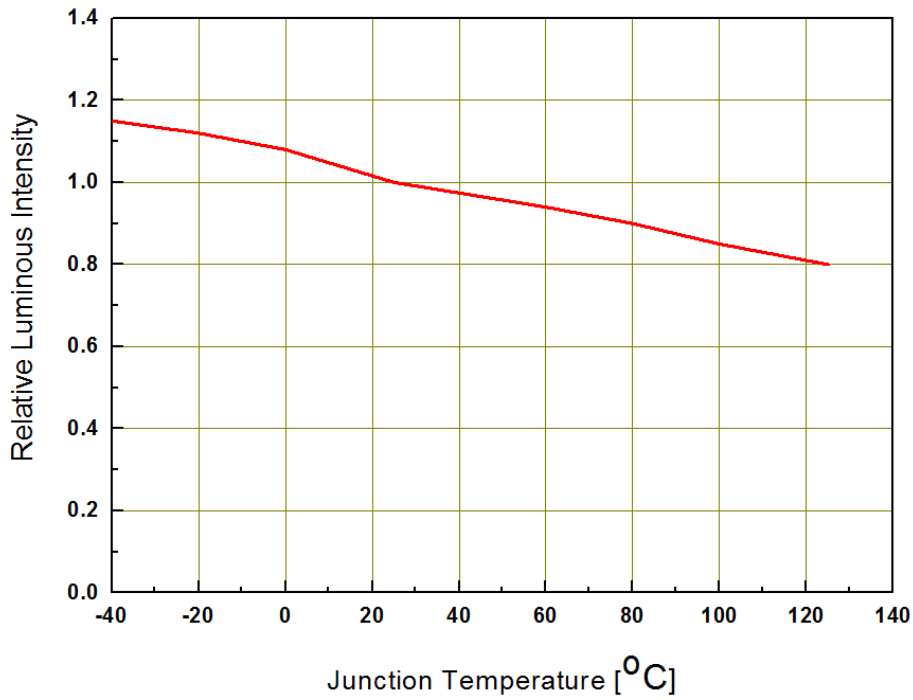

Forward Current Derating Curve

$$I_F = f(T_S)$$

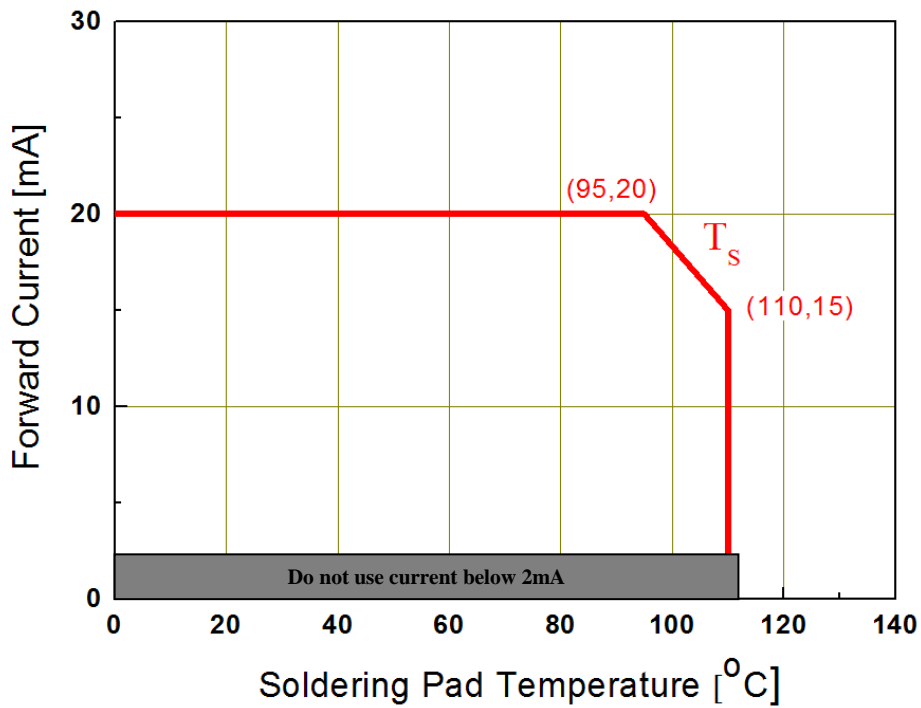

4. Binning Information

Luminous Intensity Bins

Group Bin	Minimum Luminous Intensity (mcd)	Maximum Luminous Intensity (mcd)
L1	11.2	14
L2	14	18
M1	18	22.4
M2	22.4	28
N1	28	35.5
N2	35.5	45
P1	45	56
P2	56	71
Q1	71	90
Q2	90	112
R1	112	140
R2	140	180
S1	180	224
S2	224	280
T1	280	355
T2	355	450
U1	450	560
U2	560	710
V1	710	900
V2	900	1120
AA	1120	1400
AB	1400	1800
BA	1800	2240
BB	2240	2800
CA	2800	3550
CB	3550	4500
DA	4500	5600
DB	5600	7100
EA	7100	9000
EB	9000	11200
FA	11200	14000
FB	14000	18000
GA	18000	22400

Notes:

1. Luminous flux measurement tolerance: $\pm 8\%$.
2. Highlighted Black Box is available bins.

Ice Blue Bin Structure

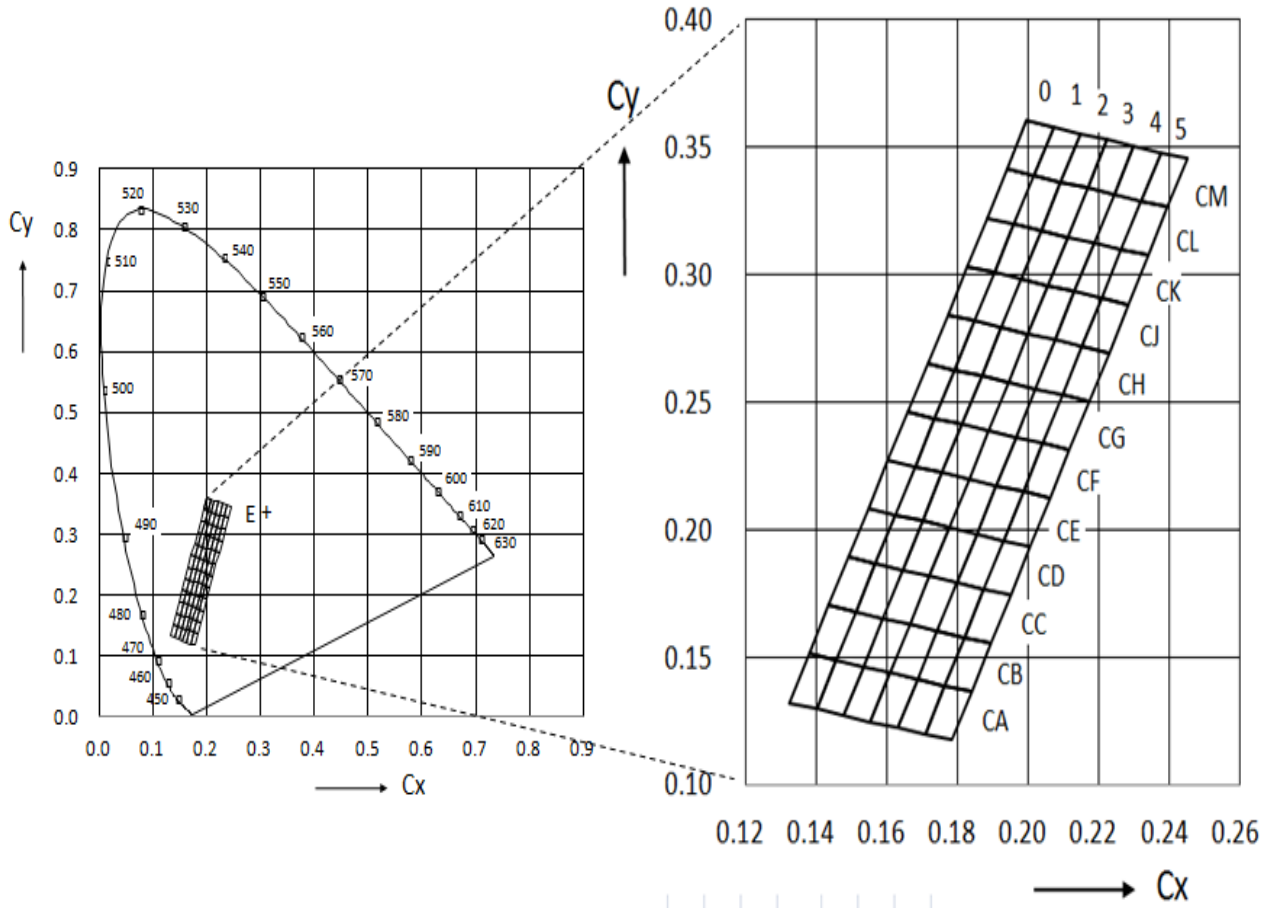

Ice Blue Bin Coordinates

Bin Code	CIE_x	CIE_y	Bin Code	CIE_x	CIE_y	Condition
CM0	0.1940	0.3415	CL3	0.2112	0.3151	I _F = 10mA
	0.1996	0.3605		0.2168	0.3341	
	0.2072	0.3580		0.2244	0.3316	
	0.2016	0.3390		0.2188	0.3126	
CM1	0.2016	0.3390	CL4	0.2188	0.3126	
	0.2072	0.3580		0.2244	0.3316	
	0.2148	0.3556		0.2319	0.3291	
	0.2092	0.3366		0.2264	0.3101	
CM2	0.2092	0.3366	CL5	0.2264	0.3101	
	0.2148	0.3556		0.2319	0.3291	
	0.2224	0.3531		0.2395	0.3267	
	0.2168	0.3341		0.2340	0.3077	
CM3	0.2168	0.3341	CK0	0.1828	0.3035	
	0.2224	0.3531		0.1884	0.3225	
	0.2299	0.3506		0.1960	0.3200	
	0.2244	0.3316		0.1904	0.3010	
CM4	0.2244	0.3316	CK1	0.1904	0.3010	
	0.2299	0.3506		0.1960	0.3200	
	0.2375	0.3481		0.2036	0.3176	
	0.2319	0.3291		0.1980	0.2986	
CM5	0.2319	0.3291	CK2	0.1980	0.2986	
	0.2375	0.3481		0.2036	0.3176	
	0.2451	0.3457		0.2112	0.3151	
	0.2395	0.3267		0.2056	0.2961	
CL0	0.1884	0.3225	CK3	0.2056	0.2961	
	0.1940	0.3415		0.2112	0.3151	
	0.2016	0.3390		0.2188	0.3126	
	0.1960	0.3200		0.2132	0.2936	
CL1	0.1960	0.3200	CK4	0.2132	0.2936	
	0.2016	0.3390		0.2188	0.3126	
	0.2092	0.3366		0.2264	0.3101	
	0.2036	0.3176		0.2208	0.2911	
CL2	0.2036	0.3176	CK5	0.2208	0.2911	
	0.2092	0.3366		0.2264	0.3101	
	0.2168	0.3341		0.2340	0.3077	
	0.2112	0.3151		0.2284	0.2887	

Ice Blue Bin Coordinates

Bin Code	CIE_x	CIE_y	Bin Code	CIE_x	CIE_y	Condition
CJ0	0.1772	0.2845	CH3	0.1945	0.2581	I _F = 10mA
	0.1828	0.3035		0.2000	0.2771	
	0.1904	0.3010		0.2077	0.2746	
	0.1848	0.2820		0.2021	0.2556	
CJ1	0.1848	0.2820	CH4	0.2021	0.2556	
	0.1904	0.3010		0.2077	0.2746	
	0.1980	0.2986		0.2153	0.2721	
	0.1924	0.2796		0.2097	0.2531	
CJ2	0.1924	0.2796	CH5	0.2097	0.2531	
	0.1980	0.2986		0.2153	0.2721	
	0.2056	0.2961		0.2229	0.2697	
	0.2000	0.2771		0.2173	0.2507	
CJ3	0.2000	0.2771	CG0	0.1660	0.2465	
	0.2056	0.2961		0.1716	0.2655	
	0.2132	0.2936		0.1792	0.2630	
	0.2077	0.2746		0.1736	0.2440	
CJ4	0.2077	0.2746	CG1	0.1736	0.2440	
	0.2132	0.2936		0.1792	0.2630	
	0.2208	0.2911		0.1869	0.2606	
	0.2153	0.2721		0.1813	0.2416	
CJ5	0.2153	0.2721	CG2	0.1813	0.2416	
	0.2208	0.2911		0.1869	0.2606	
	0.2284	0.2887		0.1945	0.2581	
	0.2229	0.2697		0.1889	0.2391	
CH0	0.1716	0.2655	CG3	0.1889	0.2391	
	0.1772	0.2845		0.1945	0.2581	
	0.1848	0.2820		0.2021	0.2556	
	0.1792	0.2630		0.1965	0.2366	
CH1	0.1792	0.2630	CG4	0.1965	0.2366	
	0.1848	0.2820		0.2021	0.2556	
	0.1924	0.2796		0.2097	0.2531	
	0.1869	0.2606		0.2043	0.2341	
CH2	0.1869	0.2606	CG5	0.2043	0.2341	
	0.1924	0.2796		0.2097	0.2531	
	0.2000	0.2771		0.2173	0.2507	
	0.1945	0.2581		0.2118	0.2317	

Ice Blue Bin Coordinates

Bin Code	CIE_x	CIE_y	Bin Code	CIE_x	CIE_y	Condition
CF0	0.1604	0.2275	CE3	0.1777	0.2011	I _F = 10mA
	0.1660	0.2465		0.1833	0.2201	
	0.1736	0.2440		0.1909	0.2176	
	0.1680	0.2250		0.1854	0.1986	
CF1	0.1680	0.2250	CE4	0.1854	0.1986	
	0.1736	0.2440		0.1909	0.2176	
	0.1813	0.2416		0.1986	0.2151	
	0.1757	0.2226		0.1930	0.1961	
CF2	0.1757	0.2226	CE5	0.1930	0.1961	
	0.1813	0.2416		0.1986	0.2151	
	0.1889	0.2391		0.2062	0.2127	
	0.1833	0.2201		0.2007	0.1937	
CF3	0.1833	0.2201	CD0	0.1492	0.1895	
	0.1889	0.2391		0.1548	0.2085	
	0.1965	0.2366		0.1624	0.2060	
	0.1909	0.2176		0.1568	0.1870	
CF4	0.1909	0.2176	CD1	0.1568	0.1870	
	0.1965	0.2366		0.1624	0.2060	
	0.2043	0.2341		0.1701	0.2036	
	0.1986	0.2151		0.1645	0.1846	
CF5	0.1986	0.2151	CD2	0.1645	0.1846	
	0.2043	0.2341		0.1701	0.2036	
	0.2118	0.2317		0.1777	0.2011	
	0.2062	0.2127		0.1721	0.1821	
CE0	0.1548	0.2085	CD3	0.1721	0.1821	
	0.1604	0.2275		0.1777	0.2011	
	0.1680	0.2250		0.1854	0.1986	
	0.1624	0.2060		0.1798	0.1796	
CE1	0.1624	0.2060	CD4	0.1798	0.1796	
	0.1680	0.2250		0.1854	0.1986	
	0.1757	0.2226		0.1930	0.1961	
	0.1701	0.2036		0.1875	0.1771	
CE2	0.1701	0.2036	CD5	0.1875	0.1771	
	0.1757	0.2226		0.1930	0.1961	
	0.1833	0.2201		0.2007	0.1937	
	0.1777	0.2011		0.1951	0.1747	

Ice Blue Bin Coordinates

Bin Code	CIE_x	CIE_y	Bin Code	CIE_x	CIE_y	Condition
CC0	0.1436	0.1705	CB3	0.1610	0.1441	$I_F = 10\text{mA}$
	0.1492	0.1895		0.1666	0.1631	
	0.1568	0.1870		0.1742	0.1606	
	0.1513	0.1680		0.1687	0.1416	
CC1	0.1513	0.1680	CB4	0.1687	0.1416	
	0.1568	0.1870		0.1742	0.1606	
	0.1645	0.1846		0.1819	0.1581	
	0.1589	0.1656		0.1764	0.1391	
CC2	0.1589	0.1656	CB5	0.1764	0.1391	
	0.1645	0.1846		0.1819	0.1581	
	0.1721	0.1821		0.1896	0.1557	
	0.1666	0.1631		0.1840	0.1367	
CC3	0.1666	0.1631	CA0	0.1324	0.1325	
	0.1721	0.1821		0.1380	0.1515	
	0.1798	0.1796		0.1457	0.1490	
	0.1742	0.1606		0.1401	0.1300	
CC4	0.1742	0.1606	CA1	0.1401	0.1300	
	0.1798	0.1796		0.1457	0.1490	
	0.1875	0.1771		0.1533	0.1466	
	0.1819	0.1581		0.1477	0.1276	
CC5	0.1819	0.1581	CA2	0.1477	0.1276	
	0.1875	0.1771		0.1533	0.1466	
	0.1951	0.1747		0.1610	0.1441	
	0.1896	0.1557		0.1554	0.1251	
CB0	0.1380	0.1515	CA3	0.1554	0.1251	
	0.1436	0.1705		0.1610	0.1441	
	0.1513	0.1680		0.1687	0.1416	
	0.1457	0.1490		0.1631	0.1226	
CB1	0.1457	0.1490	CA4	0.1631	0.1226	
	0.1513	0.1680		0.1687	0.1416	
	0.1589	0.1656		0.1764	0.1391	
	0.1533	0.1466		0.1708	0.1201	
CB2	0.1533	0.1466	CA5	0.1708	0.1201	
	0.1589	0.1656		0.1764	0.1391	
	0.1666	0.1631		0.1840	0.1367	
	0.1610	0.1441		0.1785	0.1177	

Forward Voltage Bins

Bin code	Forward Voltage [V]
10	1.00
12	1.25
15	1.50
17	1.75
20	2.00
22	2.25
25	2.50
27	2.75
30	3.00
32	3.25
35	3.50
37	3.75
40	4.00
42	4.25
45	4.50
47	4.75
50	5.00
52	5.25
55	5.50
57	5.75
60	6.00
62	6.25
65	6.50
67	6.75
70	7.00

Notes:

1. Forward voltage measurement tolerance: $\pm 0.05V$.
2. Forward voltage bins are defined at $I_F = 10mA$ operation.

5.Part Number

65-11-IB0100L-AM

Part number is designated with below details.

65-11 = Product family name.

IB = Color ^[1]

010 = Test current [mA]

0 = Lead Frame Type (0=Ag; 1=Au)

L = Brightness Level (H=High; L=Low)

AM = Automotive application

Note

^[1] Color :

Symbol	Description
C	Cool White
N	Neutral White
W	Warm White
PA	Phosphor Converted Amber
PR	Phosphor Converted Red
UB	Blue
IB	Ice Blue
SB	Sky Blue
UG	Green
UY	Yellow
UA	Amber
UR	Red
SR	Super Red
RGB	RGB-Color

6. Ordering Information

65-11-IB0100L-ABCDEFGHIJKLM-PQ-AM

Part Number of the 65-11	Order Code
65-11-IB0100L-AM	65-11-IB0100L-CM5CA0R2U12737-2T-AM

Order code contains information with below details :

ABCDEF = min/max wavelength or CCT

GHJK = min./max. luminous flux in [lm] or luminous intensity in [mcd]

LMNO = min./max. forward voltage

PQ = internal code

AM = Automotive Application

7. Mechanical Dimension

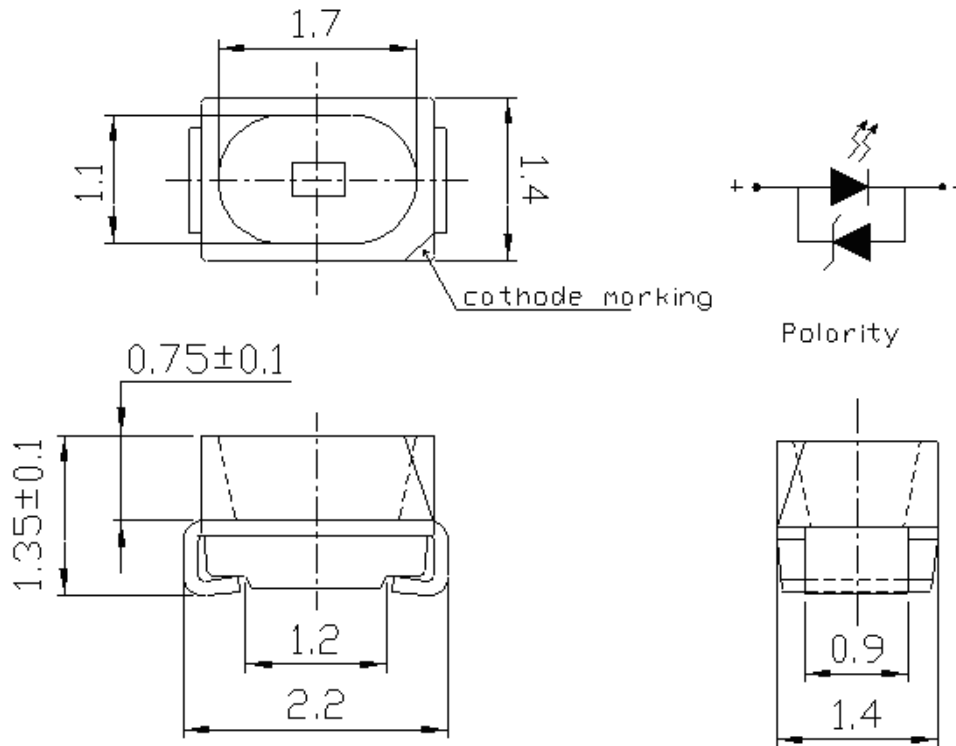

Notes:

1. Dimensions are in millimeters.
2. Tolerances unless mentioned are ± 0.1 mm.

8. Recommended Soldering Pad

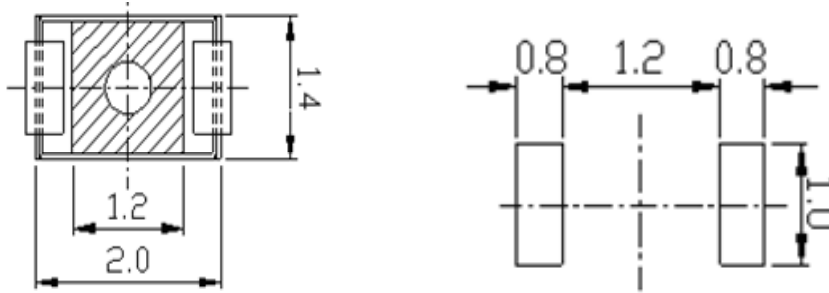

9. Reflow Soldering Profile

Soldering Condition (Reference: IPC/JEDEC J-STD-020D)

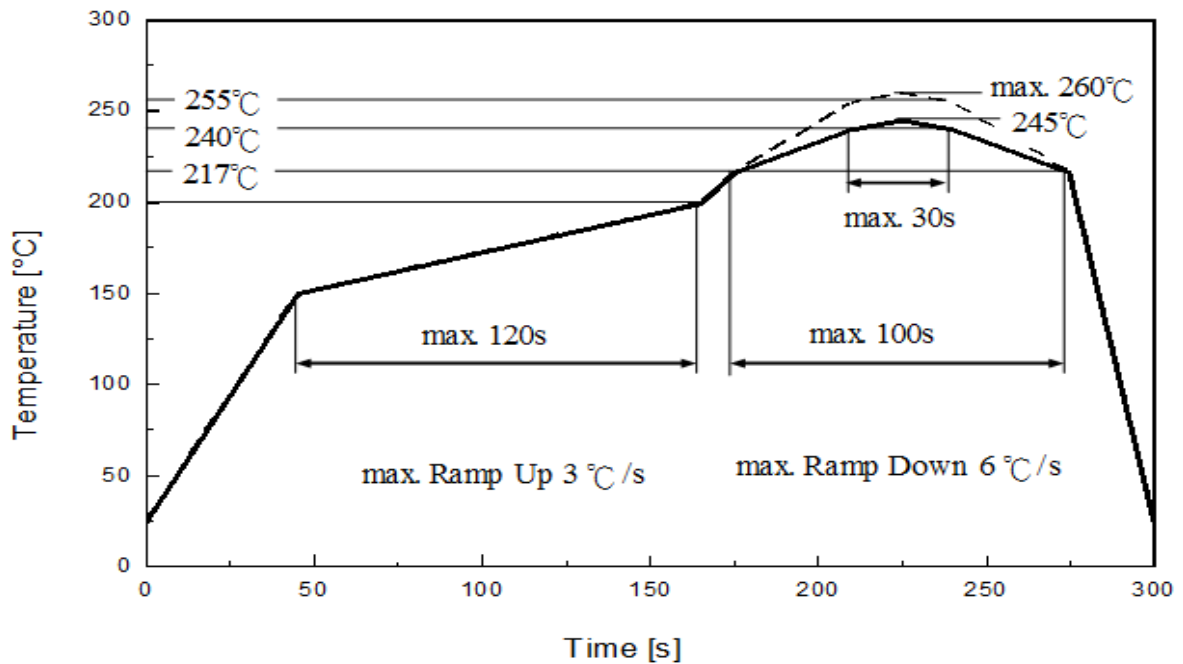

Profile Feature	Pb-Free Assembly	Unit
	Recommendation	
Ramp-up rate to preheat 25 °C to 150 °C	3	°C /sec
Time of soaking zone 150 °C to 200 °C	120	sec
Ramp-up rate to peak	3	°C /sec
Liquidus temperature	217	°C
Time above liquidus temperature	100	sec
Peak temperature (max.)	260	°C
Time within 5°C of the specified peak temperature	30	sec
Ramp-down Rate (max.)	6	°C /sec

10. Packaging Information

● Product Labeling

RoHS **(Pb) EVERLIGHT** 5

CPN: XXXXXXXXXXXXXXXXXXXX
 XXXXXXXXXXXX-XXXXXXXXXX-XXXXXXXXXX-XXXXXXXXXX-XXXXXX
 P/N: XXXXXXXXXXXX
 XXXXXXXXXXXX-XXXXXXXXXX-XXXXXXXXXX-XXXXXXXXXX-XXXXXX
 LOT NO: Y150716XXX-XXXXXXXXXX-XXXXXXXXXX
 QTY: 0123456789 HUE: XXXXXXXXXXXX
 CAT: XXXXXXXXXXXX REF: XXXXXXXXXXXX
 REFERENCE: BTPYMMDDXXXXX
 MSL-X MADE IN XXXXXX



- CPN : Customer's Product Number
- P/N : Everlight Part Number
- QTY : Packing Quantity
- CAT : Luminous Flux (Brightness) Bin
- HUE : Color Bin
- REF : Forward Voltage Bin
- LOT No : Lot Number

● Packing: Loaded Quantity 2000 pcs Per Reel

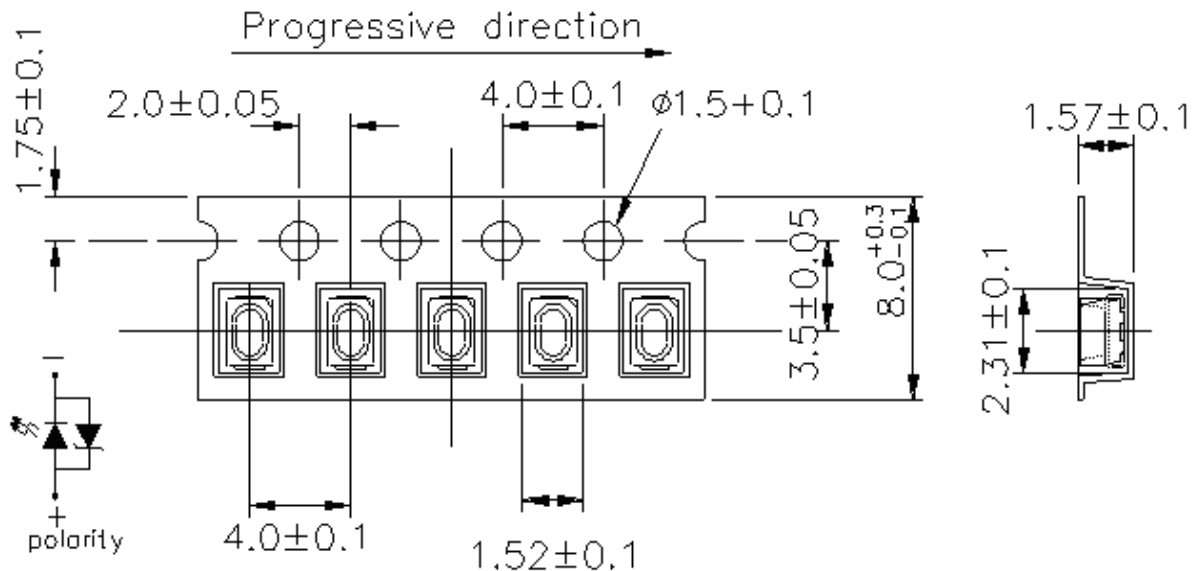

Notes:

1. Dimensions are in millimeters.
2. Tolerances for fixed dimensions are ± 0.2 mm.

Reel Dimensions

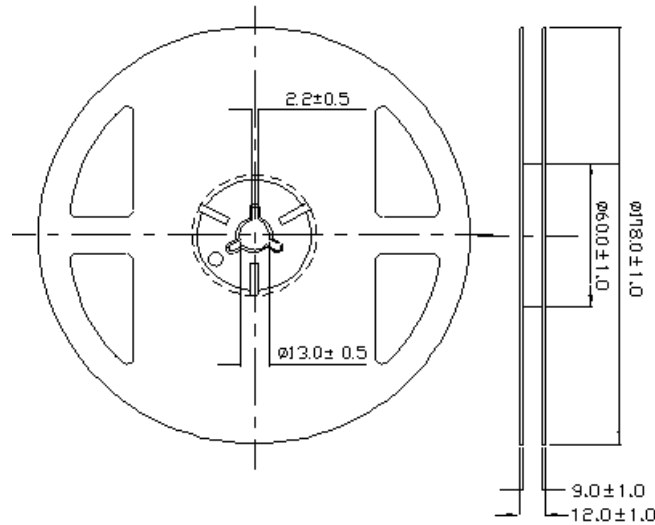

Notes:

1. Dimensions are in millimeters.
2. Tolerances unless mentioned are ± 0.2 mm.

● Moisture Resistant Packing Process

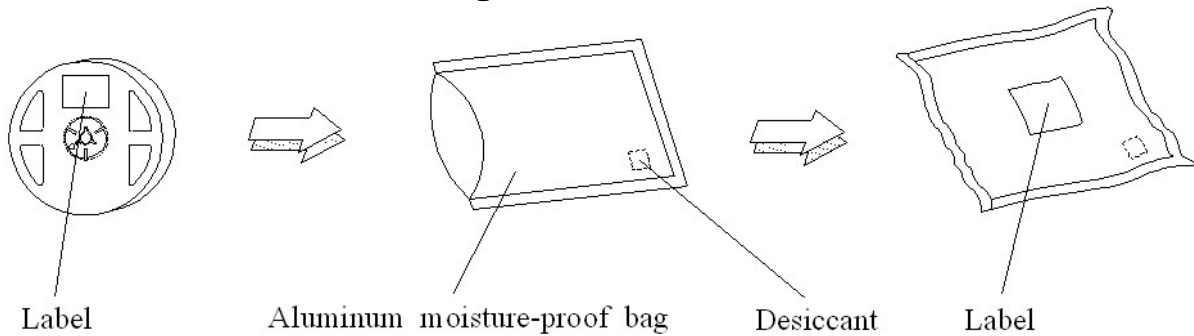

Notes:

1. Dimensions are in millimeters.
2. Tolerances unless mentioned are ± 0.2 mm.

11. Precaution for Use

1. Over-current-proof

Customer must apply resistors for protection; otherwise slight voltage shift will cause big current change (burn out will happen).

2. Assemblies

Do not stack assemblies containing LEDs to prevent damage to the optical surface of LEDs. Forces applied to the optical surface may result in the surface being damaged.

3. Soldering Condition

3.1 When soldering, do not put stress on the LEDs during heating.

3.2 After soldering, do not warp the circuit board.

4. Soldering Iron

Each terminal is to go to the tip of soldering iron temperature less than 350°C for 3 seconds within once in less than the soldering iron capacity 25W. Leave two seconds and more intervals, and do soldering of each terminal. Be careful because the damage of the product is often started at the time of the hand solder.

5. Repairing

Repair should not be done after the LEDs have been soldered. When repairing is unavoidable, a double-head soldering iron should be used (as below figure). It should be confirmed beforehand whether the characteristics of the LEDs will or will not be damaged by repairing.

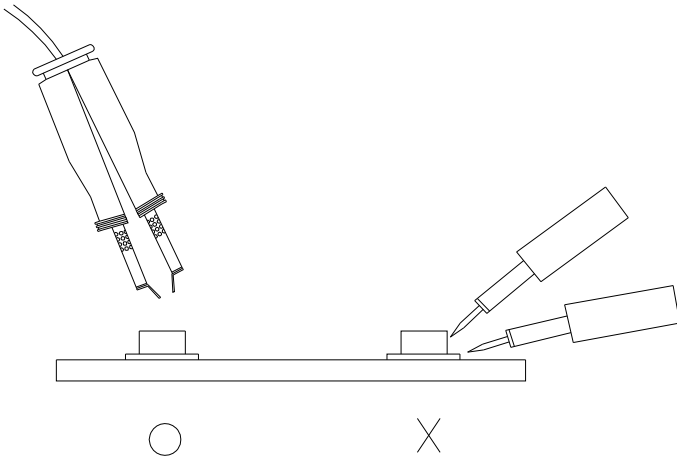

Revision History

Current version: Sep.12.2016

Issue No:

Version: 1.0

Created by: Una lin

Rev.	Subjects (major change in previous version)	Modified date
1.0	Standard data sheet	2016/09/12