

### Luminosity Full Color LED EAPL32328RGBA0

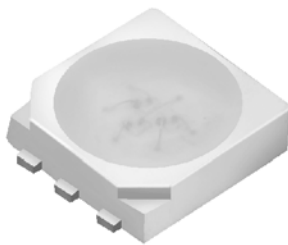

#### Features

##### Lead (Pb) Free Product - RoHS Compliant

- P-LCC-6 package.
- Colored diffused resin.
- Wide viewing angle 120°.
- Inner reflector and white package.
- Soldering methods: IR reflow soldering.

#### Applications

- Automotive backlighting or indicator: Interior and exterior lighting, Dashboard, switch, reading lamp, audio and video equipments...etc.
- Backlight: LCD, switches, symbol, mobile phone and illuminated advertising.
- Display for indoor and outdoor application.
- Ideal for coupling into light guides.
- Substitution of traditional light.
- General applications.
- Optical indicator.

## Device Selection Guide

Type	Chip Materials	Emitted Color	Resin Color
RE	AlGaInP	Brilliant Red	Water Clear
GB	InGaN / SiC	Brilliant Green	Water Clear
B2	InGaN / SiC	Blue	Water Clear

## Absolute Maximum Ratings (Ta=25°C)

Parameter	Symbol	Type	Rating	Unit
Reverse Voltage	$V_R$	RE	10	V
		GB	5	
		B2	5	
Forward Current	$I_F$	RE	30	mA
		GB	30	
		B2	30	
Peak Forward Current (Duty 1/10 @1KHz)	$I_{FP}$	RE	100	mA
		GB	100	
		B2	100	
Power Dissipation	$P_d$	RE	60	mW
		GB	110	
		B2	110	
Junction Temperature	$T_j$	---	115	°C
Operating Temperature	$T_{opr}$	---	-40 ~ +85	°C
Storage Temperature	$T_{stg}$	---	-40 ~ +90	°C
ESD	$ESD_{HBM}$	RE	1000	V
		GB	500	
		B2	500	
Soldering Temperature	$T_{sol}$	Reflow Soldering : 260 °C for 10 sec. Hand Soldering : 350 °C for 3 sec.		

### Electro-Optical Characteristics (Ta=25°C)

Parameter	Symbol	Type	Min.	Typ.	Max.	Unit	Condition
Luminous Intensity	I <sub>v</sub>	RE	560	---	1120	mcd	I <sub>F</sub> =20mA
		GB	1120	---	2800		
		B2	225	---	565		
Viewing Angle	2θ <sub>1/2</sub>	---	---	120	---	deg	I <sub>F</sub> =20mA
Forward Voltage	V <sub>F</sub>	RE	1.75	---	2.55	V	
		GB	2.7	---	3.7		
		B2	2.7	---	3.7		
Reverse Current	I <sub>R</sub>	RE	---	---	10	μA	V <sub>R</sub> =10V
		GB	---	---	10		V <sub>R</sub> =5V
		B2	---	---	10		

Note:

1. Tolerance of Luminous Intensity: ±11%
2. Tolerance of Chromaticity Coordinates is ±0.01
3. Tolerance of Forward Voltage: ±0.1V

### Bin Range of Luminous Intensity

Type	Bin Code	Min.	Max.	Unit	Condition
RE	U2	560	710	mcd	I <sub>F</sub> =20mA
	V1	710	900		
	V2	900	1120		
GB	W1	1120	1420	mcd	I <sub>F</sub> =20mA
	W2	1420	1800		
	X1	1800	2240		
	X2	2240	2800		
B2	S2	225	285	mcd	I <sub>F</sub> =20mA
	T1	285	360		
	T2	360	450		
	U1	450	565		

**Bin Range of Chromaticity Coordinates Specifications**

Type	Bin Code	CIE_x	CIE_y	Condition
RE	RE1	0.6850	0.2900	I <sub>F</sub> =20mA
		0.6600	0.3150	
		0.6900	0.3150	
		0.7150	0.2900	
Type	Bin Code	CIE_x	CIE_y	Condition
GB	GB1	0.1660	0.6760	I <sub>F</sub> =20mA
		0.1360	0.7390	
		0.1760	0.7500	
		0.2010	0.6860	
	GB2	0.2010	0.6860	
		0.1760	0.7500	
		0.2200	0.7450	
		0.2370	0.6840	
Type	Bin Code	CIE_x	CIE_y	Condition
B2	B21	0.1390	0.0350	I <sub>F</sub> =20mA
		0.1290	0.0500	
		0.1450	0.0720	
		0.1520	0.0560	
	B22	0.1290	0.0500	
		0.1130	0.0800	
		0.1340	0.1050	
		0.1450	0.0720	

**Typical Electro-Optical Characteristics Curves**  
Typical Curve of Spectral Distribution

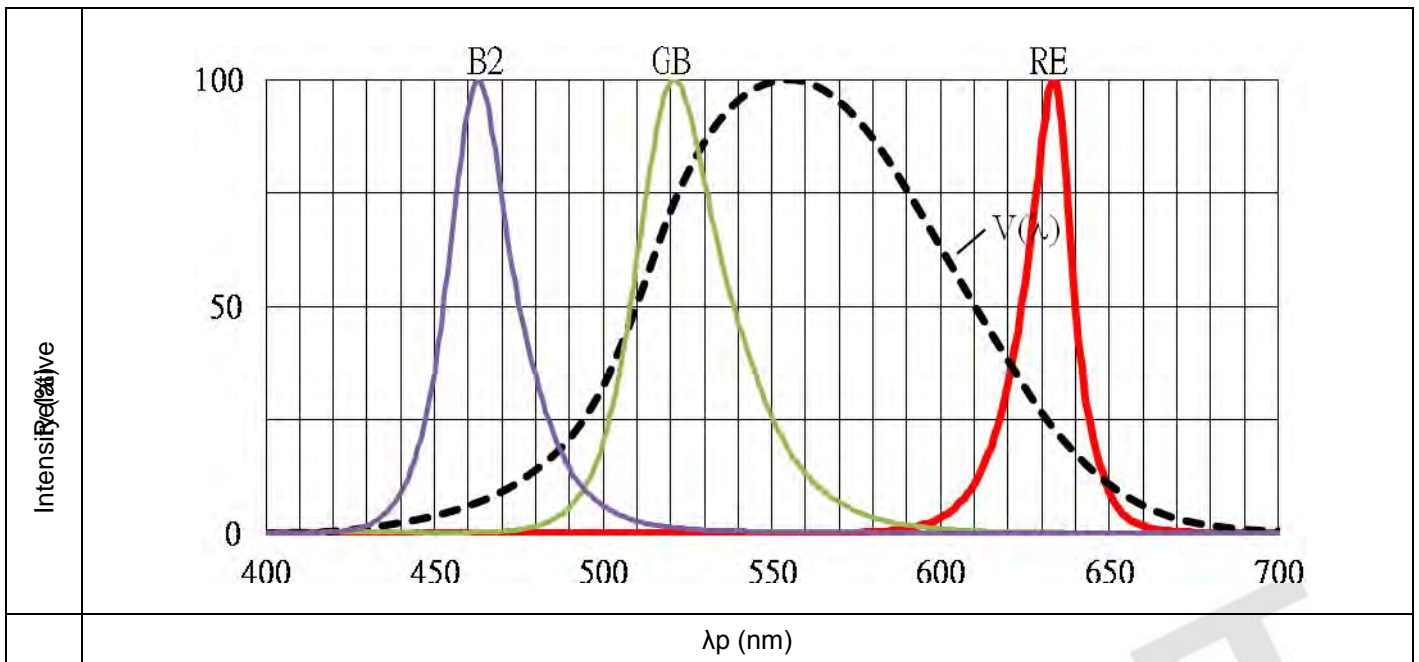

Note:  $V(\lambda)$ =Standard eye response curve;

**Diagram Characteristics of Radiation**

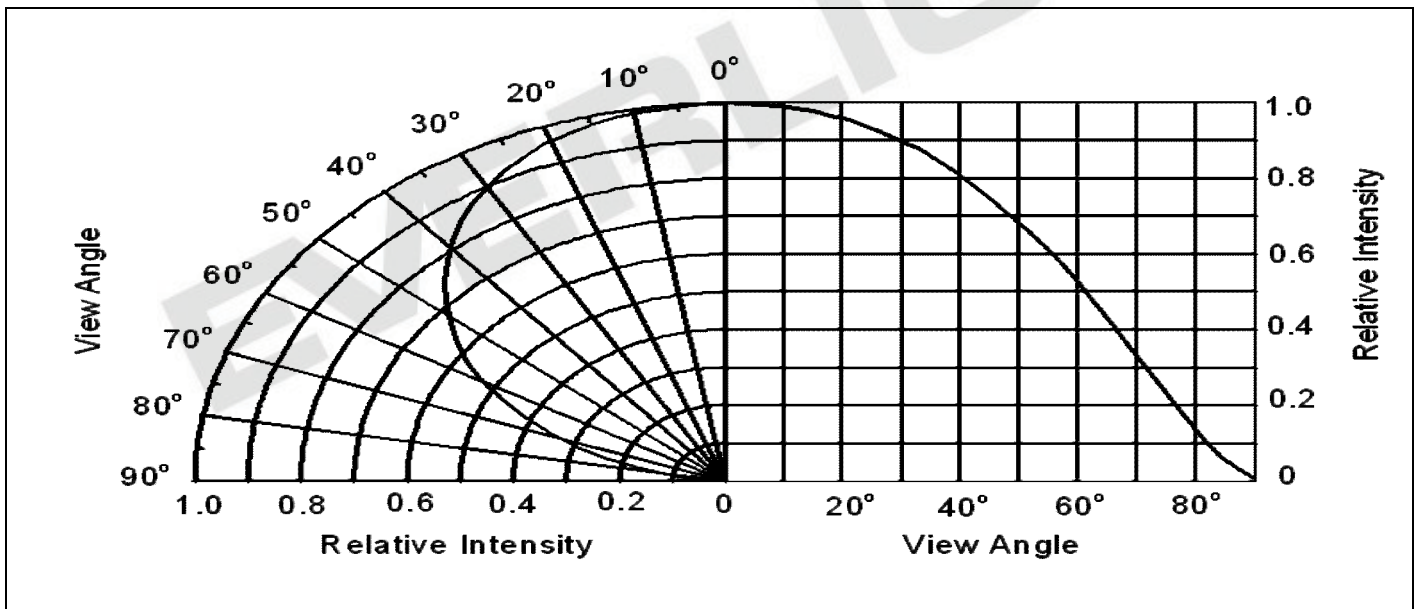

**Typical Electro-Optical Characteristics Curves (RE)**

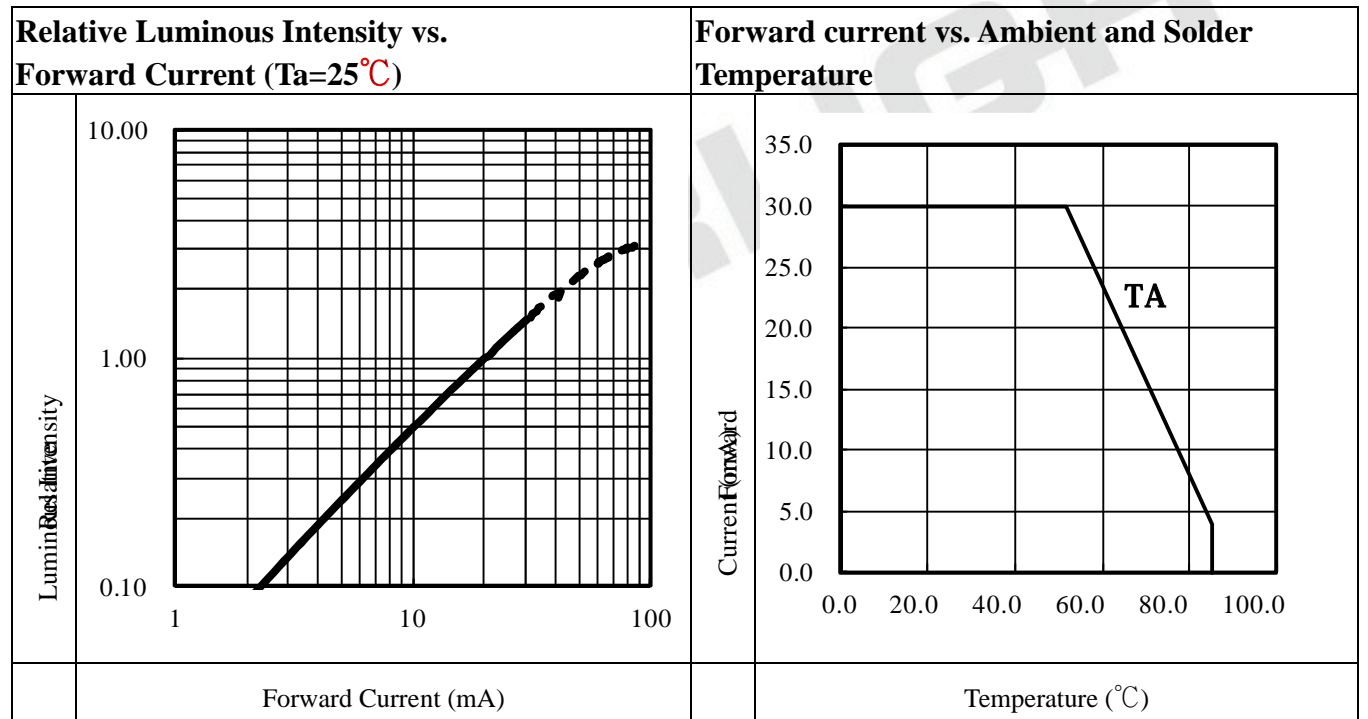
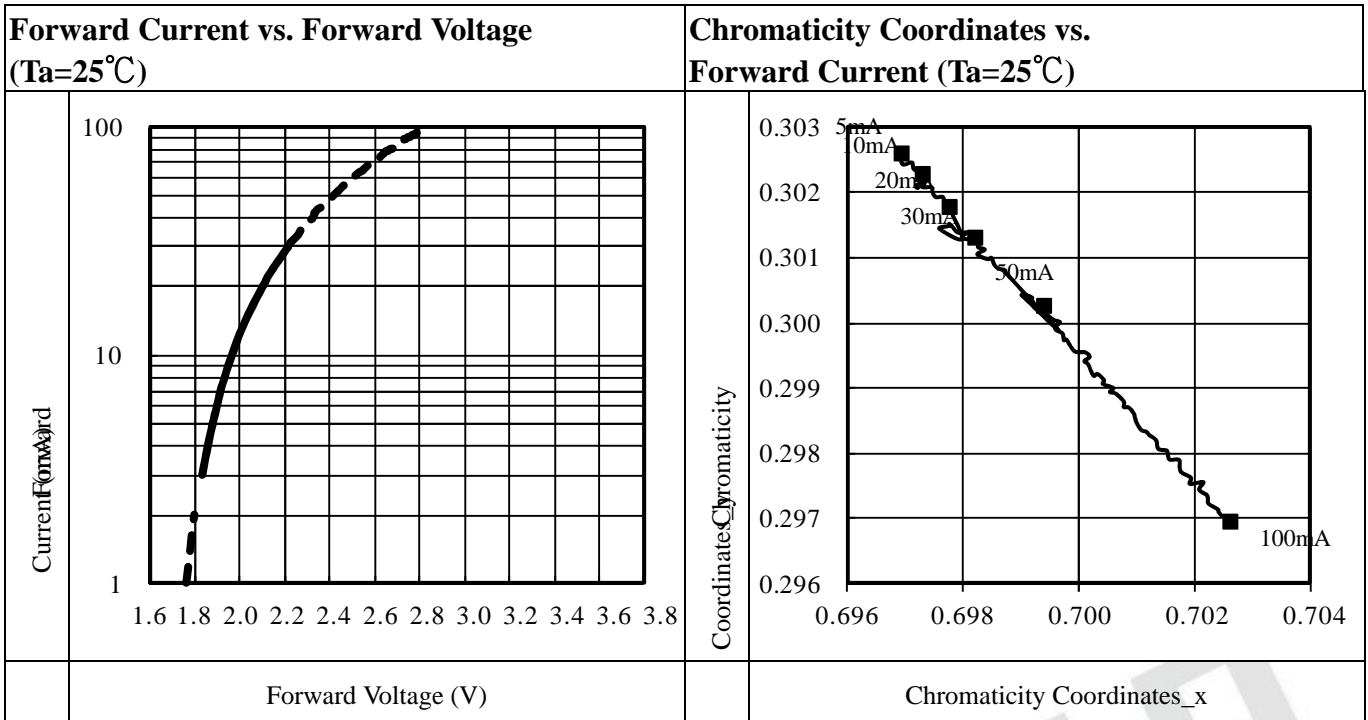

**Typical Electro-Optical Characteristics Curves (GB)**

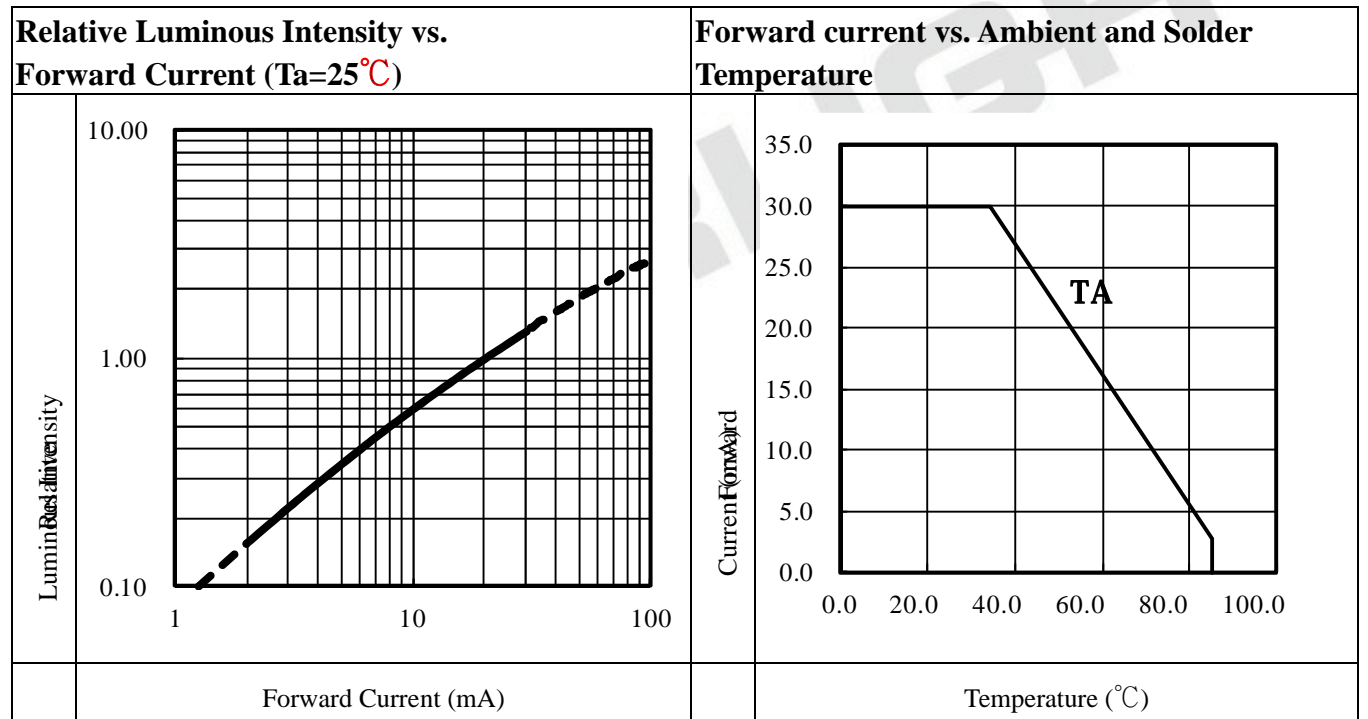
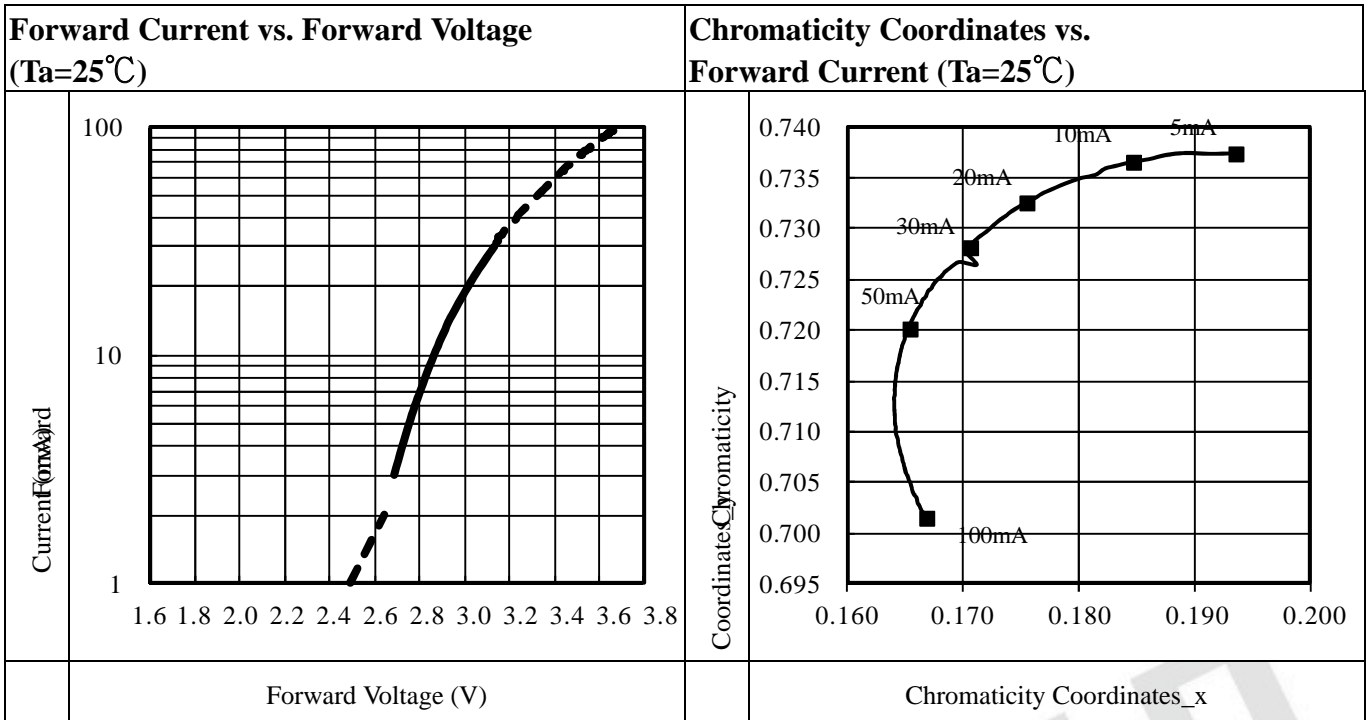

**Typical Electro-Optical Characteristics Curves (B2)**

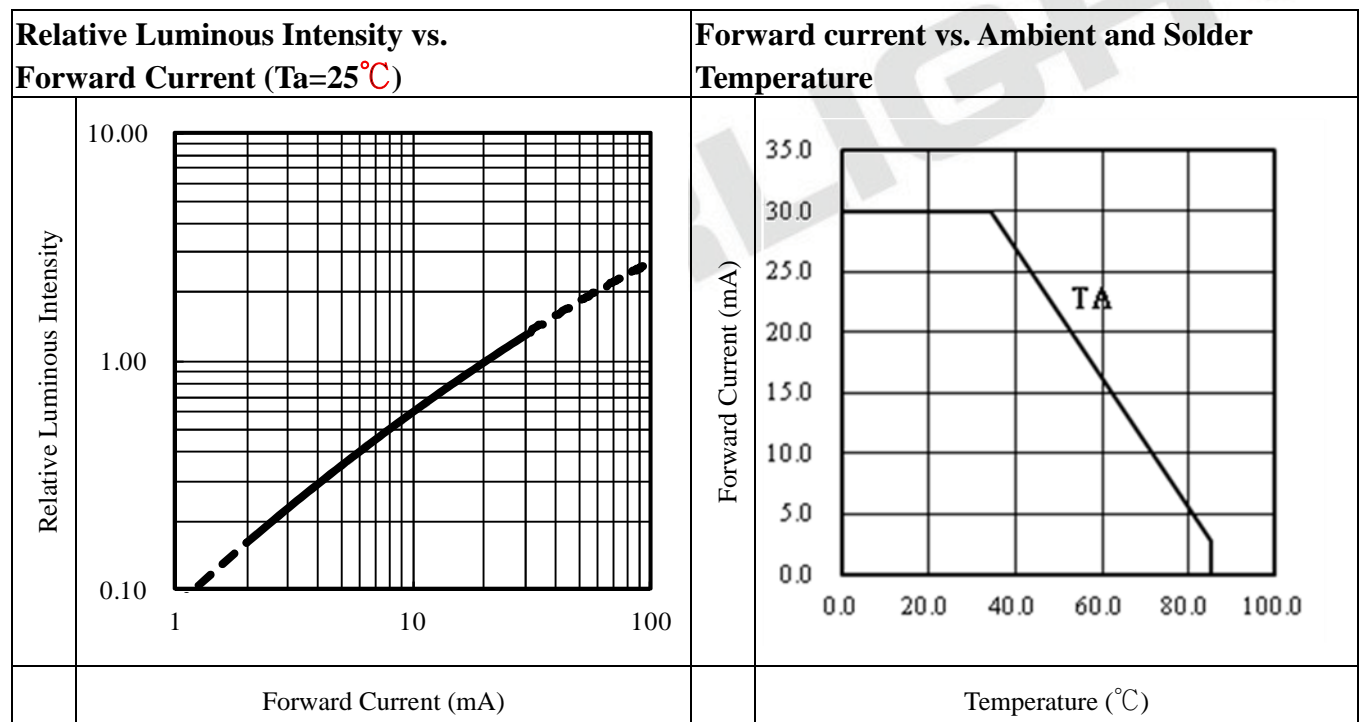
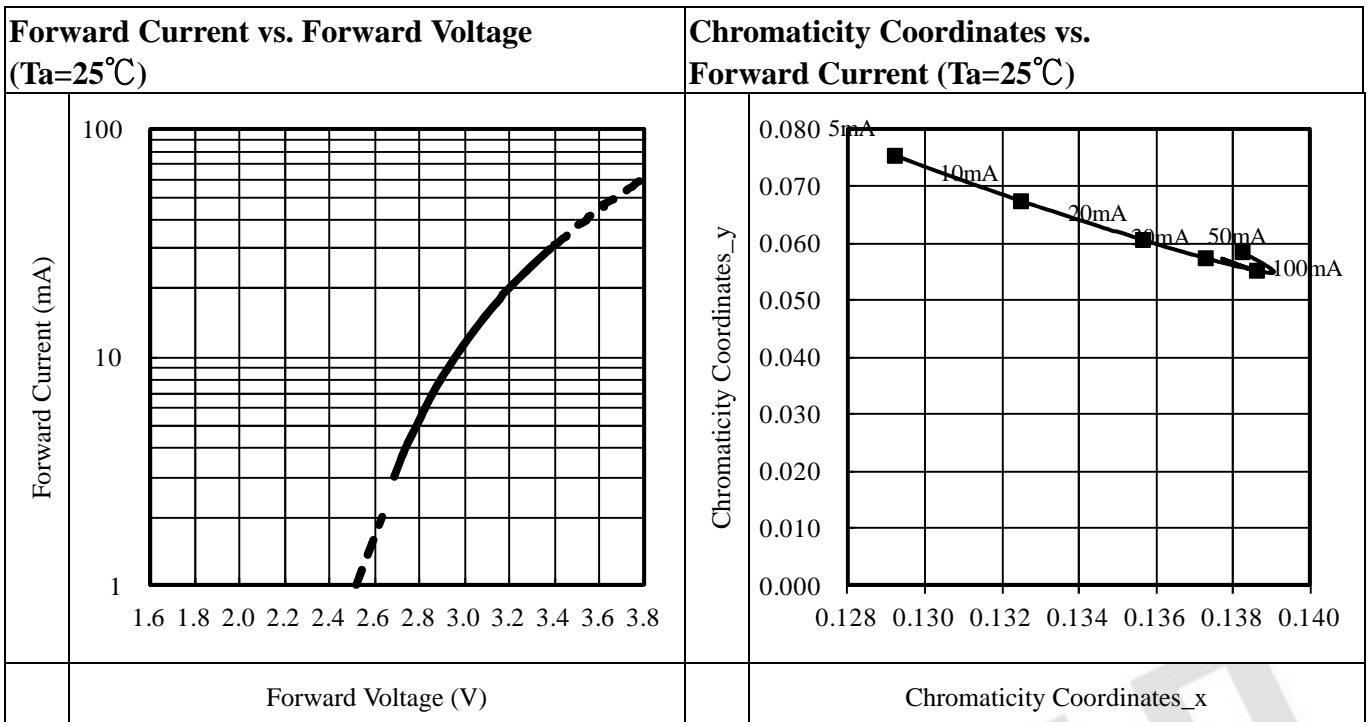



**Package Dimension**

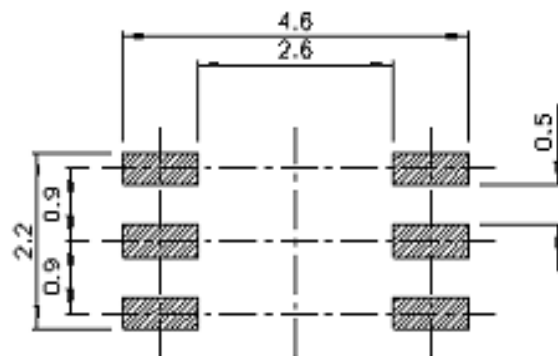
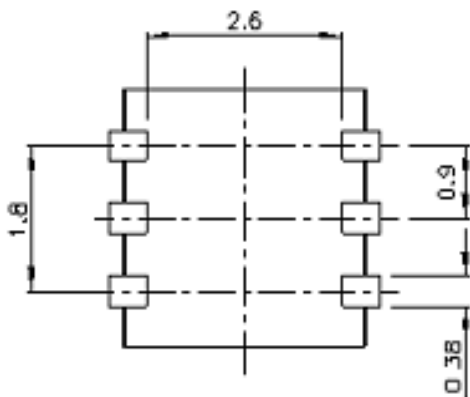
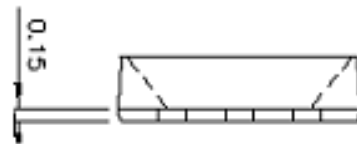
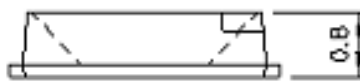
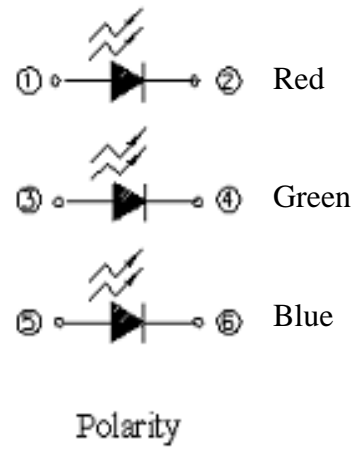
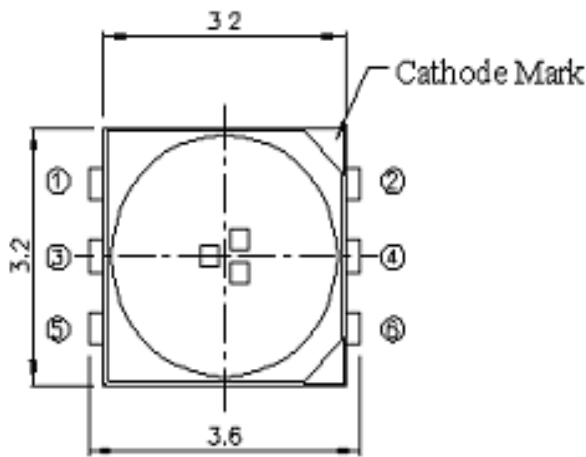

Recommended soldering pad design

Note: Tolerances unless mentioned  $\pm 0.1$ mm. Unit = mm

### Moisture Resistant Packing Materials

#### Label Explanation

- CPN: Customer's Product Number
- P/N: Product Number
- QTY: Packing Quantity
- CAT: Luminous Intensity Rank
- HUE: Dom. Wavelength Rank
- REF: Forward Voltage Rank
- LOT No: Lot Number

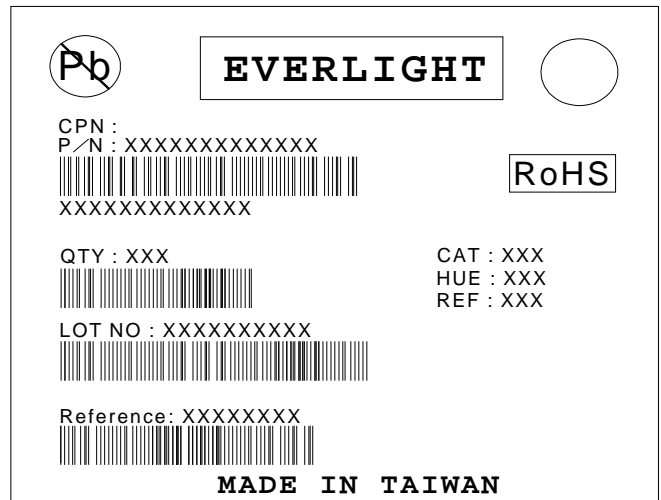

#### Reel Dimensions

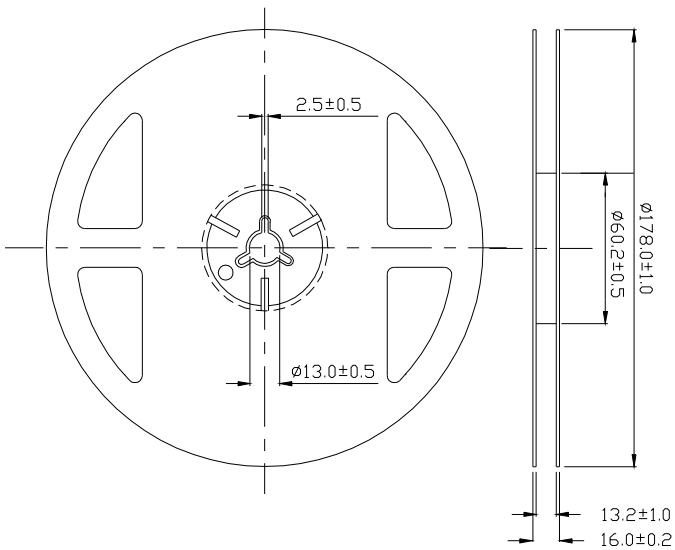

Note: Unit = mm

**Carrier Tape Dimensions: Loaded Quantity 2000 pcs Per Reel**

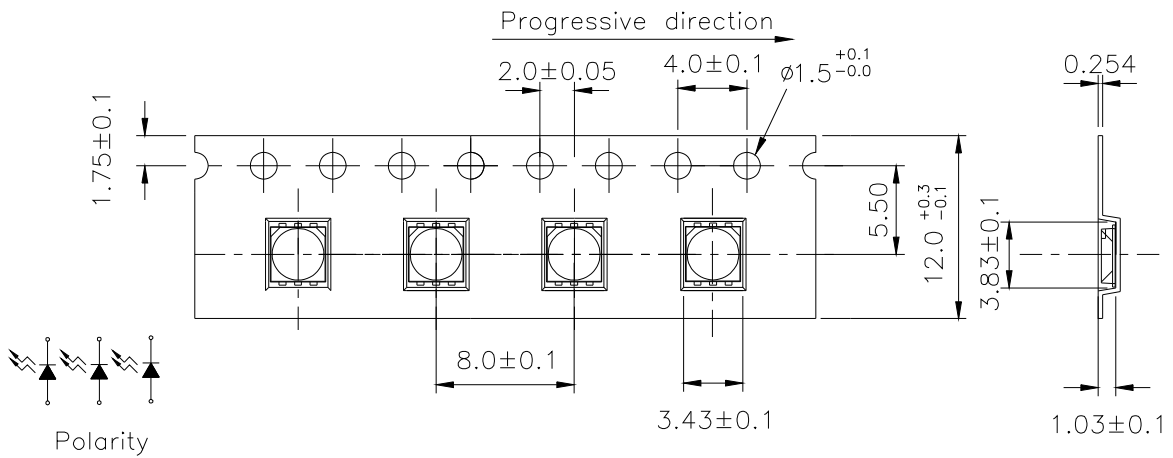

**Note:**

- 1.The tolerances unless mentioned is : ±0.1mm,Unit = mm
- 2.Minimum packing amount is 250/500/1000/2000 pcs per reel

**Moisture Resistant Packing Process**

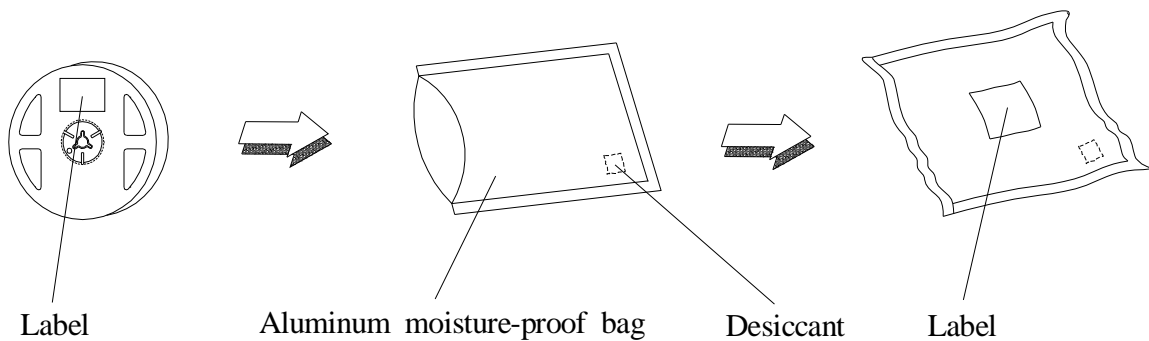

**Note:**

Tolerances unless mentioned ±0.1mm. Unit = mm

## Precautions For Use

### 1. Over-current-proof

Customer must apply resistors for protection, otherwise slight voltage shift will cause big current change ( Burn out will happen ).

### 2. Storage

2.1 Do not open moisture proof bag before the products are ready to use.

2.2 Before opening the package: The LEDs should be kept at 30°C or less and 90%RH or less.

2.3 After opening the package: The LED's floor life is 1 year under 30 deg C or less and 60% RH or less.

If unused LEDs remain, it should be stored in moisture proof packages.

2.4 If the moisture absorbent material (silica gel) has faded away or the LEDs have exceeded the storage time, baking treatment should be performed using the following conditions.

Baking treatment : 60±5°C for 24 hours.

### 3. Soldering Condition

#### 3.1 Pb-free solder temperature profile

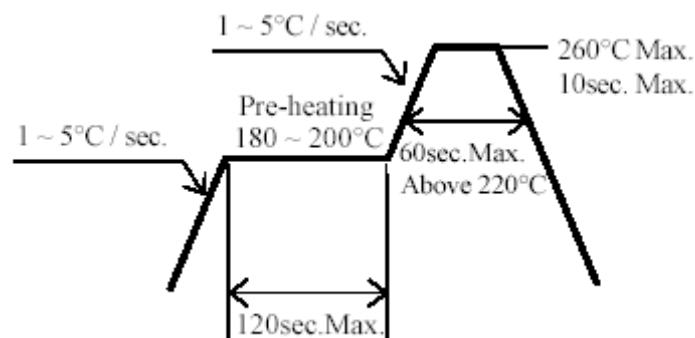

3.2 Reflow soldering should not be done more than two times.

3.3 When soldering, do not put stress on the LEDs during heating.

3.4 After soldering, do not warp the circuit board.

#### 4. Soldering Iron

Each terminal is to go to the tip of soldering iron temperature less than 350°C for 3 seconds within once in less than the soldering iron capacity 25W. Leave two seconds and more intervals, and do soldering of each terminal. Be careful because the damage of the product is often started at the time of the hand solder.

#### 5. Repairing

Repair should not be done after the LEDs have been soldered. When repairing is unavoidable, a double-head soldering iron should be used (as below figure). It should be confirmed beforehand whether the characteristics of the LEDs will or will not be damaged by repairing.

