

EAPL3527WA8



Features

- P-LCC-2 package.
- White package.
- Optical indicator.
- Colorless clear window.
- Wide viewing angle.
- Suitable for vapor-phase reflow, Infrared reflow and wave solder processes.
- Computable with automatic placement equipment.
- Available on tape and reel (12mm Tape).
- Pb-free.
- The product itself will remain within RoHS compliant version

Descriptions

- The EAPL3527 is available in soft orange, green, blue and yellow. Due to the package design, the LED has wide viewing angle and optimized light coupling by inter reflector. This feature makes the Top View LEDs ideal for light pipe application. The low current requirement makes this device ideal for portable equipment or any other application where power is at a premium.

Applications

- Telecommunication: indicator and backlighting in telephone and fax.
- Flat backlight for LCD, switch and symbol.
- Light pipe application.
- General use.

Device Selection Guide

| | | |
|------------------|----------------------|--------------------|
| Chip | Emitted Color | Resin Color |
| Material | | |
| InGaN/SiC | Pure White | Water Clear |

Package Dimensions

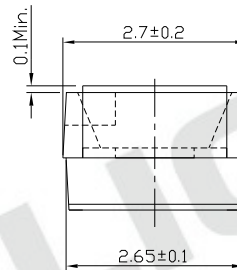
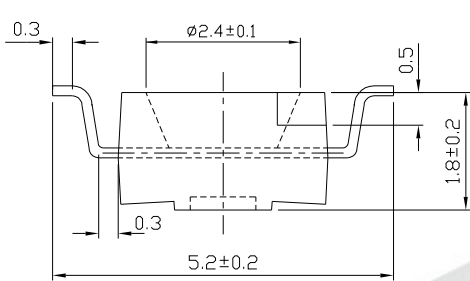
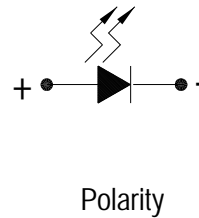
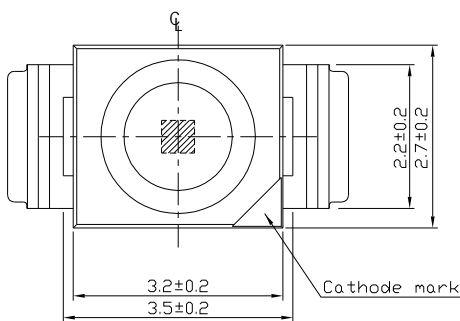

For reflow soldering (propose)

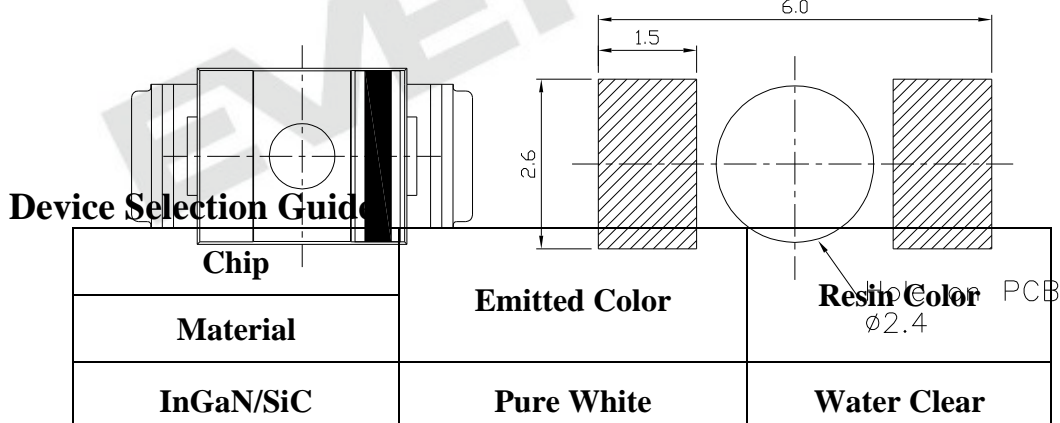

Device Selection Guide

| | | |
|------------------|----------------------|--------------------|
| Chip | Emitted Color | Resin Color |
| Material | | |
| InGaN/SiC | Pure White | Water Clear |

Notes: The tolerances unless mentioned is ± 0.1 mm; Unit = mm

Absolute Maximum Ratings (Ta=25)

| Parameter | Symbol | Rating | Unit |
|--|-----------|--|---------------------------|
| Reverse Voltage | V_R | 5 | V |
| Forward Current | I_F | 30 | mA |
| Peak Forward Current (Duty 1/10 @1KHz) | I_{FP} | 100 | mA |
| Power Dissipation | P_d | 120 | mW |
| Electrostatic Discharge(HBM) | ESD | 1000 | V |
| Operating Temperature | T_{opr} | -40 ~ +85 | |
| Storage Temperature | T_{stg} | -40 ~ +90 | |
| Soldering Temperature | T_{sol} | Reflow Soldering : 260 Hand Soldering : 350 | for 10 sec. for 3 sec. |

Electro-Optical Characteristics (Ta=25)

| Parameter | Symbol | Min. | Typ. | Max. | Units | Condition |
|--------------------|-----------------|------|------|------|-------|------------|
| Luminous Intensity | I_v | 180 | -- | 450 | mcd | $I_F=20mA$ |
| Viewing Angle | $2\theta_{1/2}$ | -- | 120 | -- | deg | $I_F=20mA$ |
| Forward Voltage | V_F | 2.55 | -- | 3.95 | V | $I_F=20mA$ |
| Reverse Current | I_R | -- | -- | 50 | Ma | $V_R=5V$ |

Notes:

- 1.Tolerance of Luminous Intensity : $\pm 11\%$
- 2.Tolerance of Forward Voltage : $\pm 0.1V$

Bin Range of Luminous Intensity

| Bin | Min | Max | Unit | Condition |
|-----|-----|-----|------|----------------------|
| S1 | 180 | 225 | mcd | I _F =20mA |
| S2 | 225 | 285 | | |
| T1 | 285 | 360 | | |
| T2 | 360 | 450 | | |

Bin Range of Forward Voltage

| Group | Bin | Min. | Max. | Unit | Condition |
|-------|-----|------|------|------|----------------------|
| B8 | 4 | 2.55 | 2.75 | v | I _F =20mA |
| | 5 | 2.75 | 3.05 | | |
| | 6 | 3.05 | 3.35 | | |
| | 7 | 3.35 | 3.65 | | |
| | 8 | 3.65 | 3.95 | | |

Notes:

- 1.Tolerance of Luminous Intensity : ±11%
- 2.Tolerance of Forward Voltage : ±0.1V

Bin Range of Chromaticity Coordinates

I_F=20mA

| Group | Bin Code | CIE_x | CIE_y | Bin Code | CIE_x | CIE_y | Condition |
|-------|----------|-------|-------|----------|-------|-------|----------------------|
| E | A0 | 0.280 | 0.248 | B3 | 0.287 | 0.295 | I _F =20mA |
| | | 0.264 | 0.267 | | 0.283 | 0.305 | |
| | | 0.283 | 0.305 | | 0.304 | 0.330 | |
| | | 0.296 | 0.276 | | 0.307 | 0.315 | |
| | B4 | 0.307 | 0.315 | B5 | 0.296 | 0.276 | |
| | | 0.304 | 0.33 | | 0.287 | 0.295 | |
| | | 0.33 | 0.36 | | 0.307 | 0.315 | |
| | | 0.33 | 0.339 | | 0.311 | 0.294 | |
| | B6 | 0.311 | 0.294 | | | | |
| | | 0.307 | 0.315 | | | | |
| | | 0.330 | 0.339 | | | | |
| | | 0.330 | 0.318 | | | | |

Notes: Tolerance of Chromaticity Coordinates : ±0.01

The C.I.E. 1931 Chromaticity Diagram

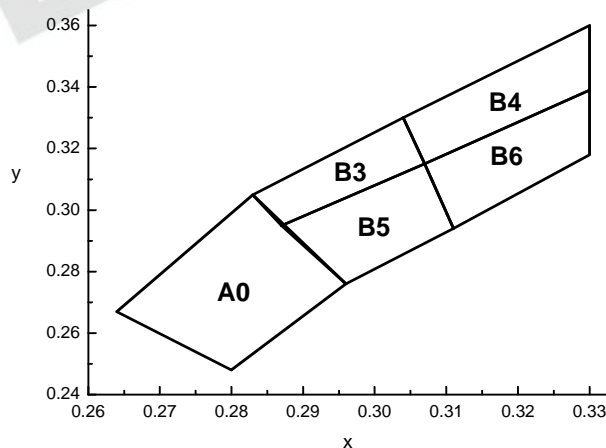

Typical Electro-Optical Characteristics Curves

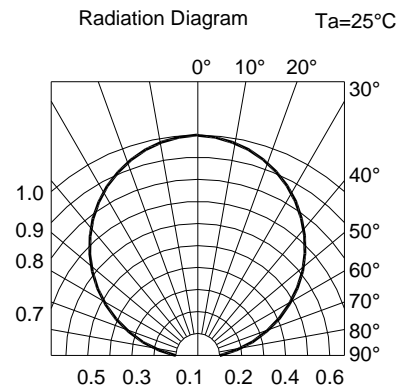
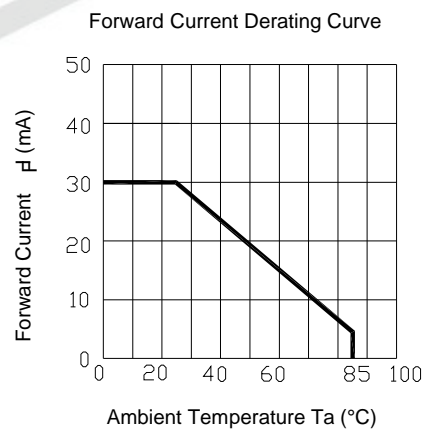
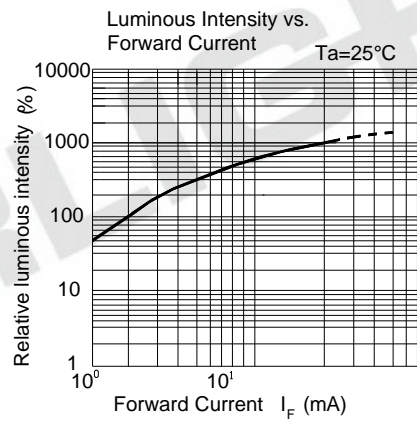
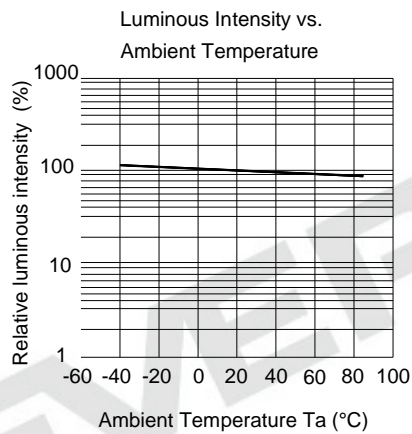
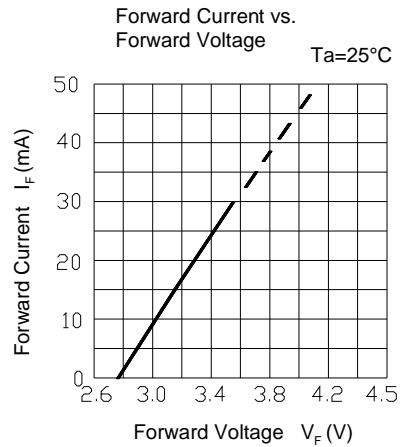
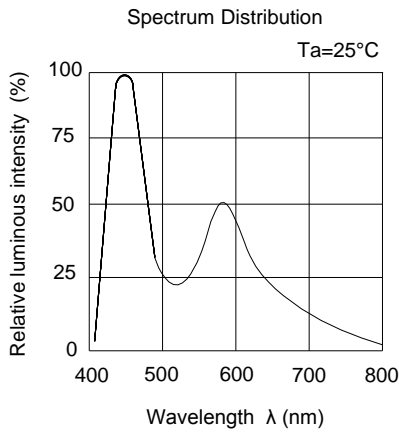

Label Explanation

CAT: Luminous Intensity Rank

HUE: Chromaticity Coordinates

REF: Forward Voltage Rank

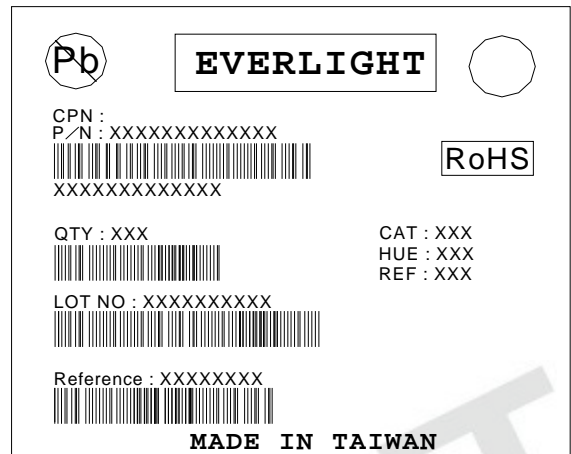

Reel Dimensions

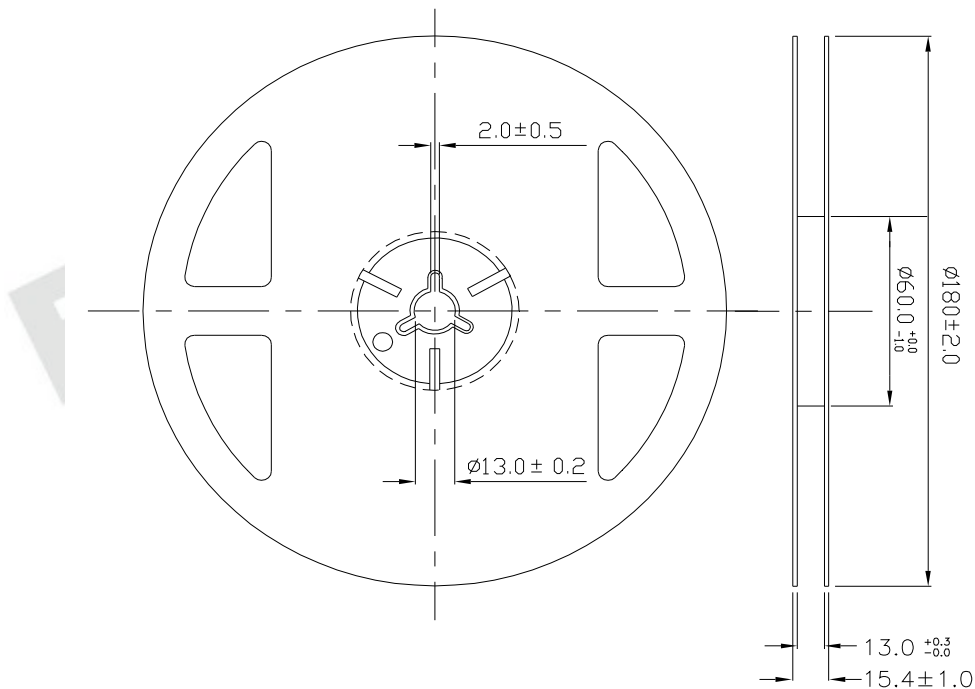

Note: The tolerances unless mentioned is ± 0.1 mm; Unit = mm

Carrier Tape Dimensions: Loaded Quantity 2000 pcs Per Reel.

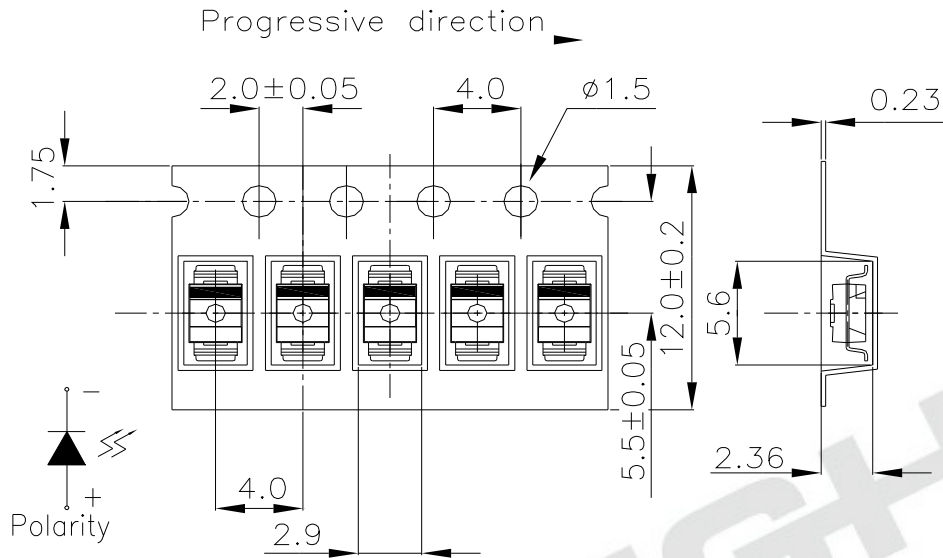

Note: Tolerances unless mentioned is ±0.1mm; Unit = mm

Moisture Resistant Packaging

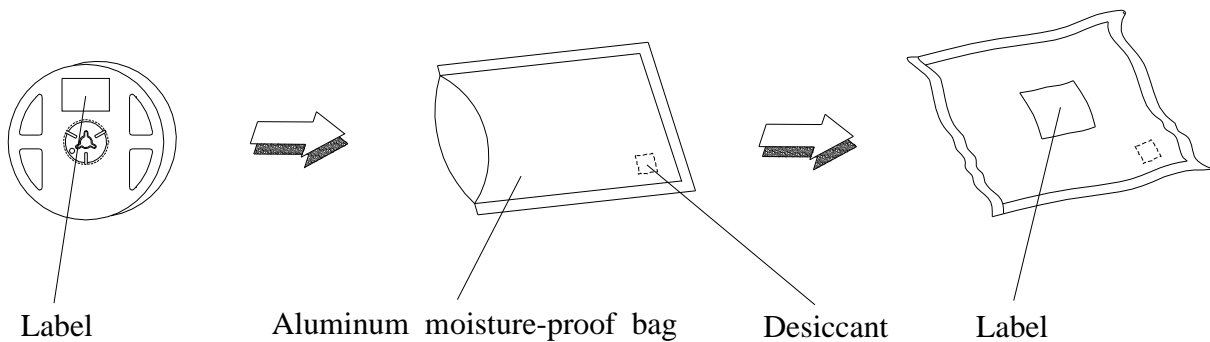

Reliability Test Items and Conditions

The reliability of products shall be satisfied with items listed below.

Confidence level : 90%

LTPD : 10%

| No. | Items | Test Condition | Test Hours/Cycles | Sample Size | Ac/Re |
|-----|----------------------------------|--|-------------------|-------------|-------|
| 1 | Reflow Soldering | Temp. : 260 ±5 Max. 10 sec. | 6 Min. | 22 PCS. | 0/1 |
| 2 | Temperature Cycle | H : +100 15min 5 min L : -40 15min | 300 Cycles | 22 PCS. | 0/1 |
| 3 | Thermal Shock | H : +100 5min 10 sec L : -10 5min | 300 Cycles | 22 PCS. | 0/1 |
| 4 | High Temperature Storage | Temp. : 100 | 1000 Hrs. | 22 PCS. | 0/1 |
| 5 | Low Temperature Storage | Temp. : -40 | 1000 Hrs. | 22 PCS. | 0/1 |
| 6 | DC Operating Life | IF = 20 mA | 1000 Hrs. | 22 PCS. | 0/1 |
| 7 | High Temperature / High Humidity | 85 / 85%RH | 1000 Hrs. | 22 PCS. | 0/1 |

Precautions for Use

1. Over-current-proof

Customer must apply resistors for protection, otherwise slight voltage shift will cause big current change (Burn out will happen).

2. Storage

2.1 Do not open moisture proof bag before the products are ready to use.

2.2 Before opening the package: The LEDs should be kept at 30% or less and 90%RH or less.

2.3 After opening the package: The LED's floor life are 168 hours under 30% or less and 60% RH or less.

If unused LEDs remain, it should be stored in moisture proof packages.

2.4 If the moisture absorbent material (silica gel) has faded away or the LEDs have exceeded the storage time, baking treatment should be performed using the following conditions.

Baking treatment : 60 ± 5 for 24 hours.

3. Soldering Condition

3.1 Pb-free solder temperature profile

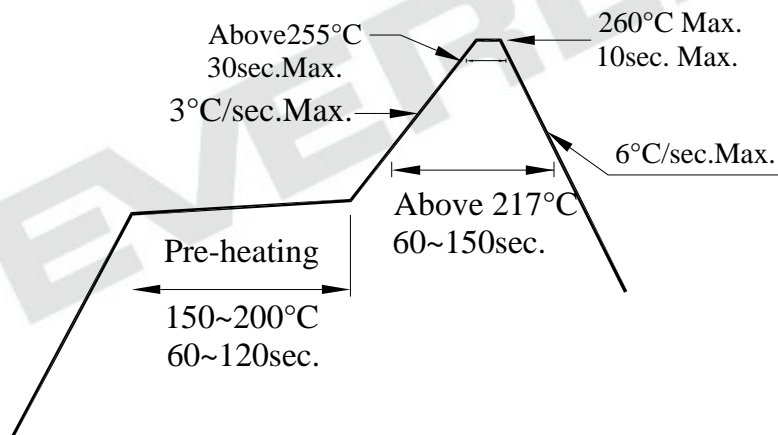

3.2 Reflow soldering should not be done more than two times.

3.3 When soldering, do not put stress on the LEDs during heating.

3.4 After soldering, do not warp the circuit board.

4. Soldering Iron

Each terminal is to go to the tip of soldering iron temperature less than 350 for 3 seconds within once in less than the soldering iron capacity 25W. Leave two seconds and more intervals, and do soldering of each terminal. Be careful because the damage of the product is often started at the time of the hand solder.

5. Repairing

Repair should not be done after the LEDs have been soldered. When repairing is unavoidable, a double-head soldering iron should be used (as below figure). It should be confirmed beforehand whether the characteristics of the LEDs will or will not be damaged by repairing.

