

P-LED EALP05SXAWA0



Features

- . High Flux Output.
- . Low Profile.
- . Low Thermal Resistance.
- . Low Power Consumption
- . The phosphor filled in the reflector converts the blue emission of GaN chip to ideal white.
- . Typical chromaticity coordinates $x=0.30, y=0.29$ according to CIE1931
- . The product itself will remain within RoHS compliant version.
- . Compliance with EU REACH.
- . Compliance Halogen Free .(Br <900 ppm ,Cl <900 ppm , Br+Cl < 1500 ppm).

Descriptions

This revolutionary package design allows the light designer to reduce the number of LEDs required and provide a more uniform and unique illuminated appearance than with other LED solutions. This is possible through the efficient optical package design and high-current capabilities.

The low profile package can be easily coupled with reflectors or lenses to efficiently distribute light and provide the desired light appearance.

Applications

- . Automotive Lighting
- . Electronic Signs and Signals
- . Special Lighting application

Device Selection Guide

| PART NO. | Chip | | Lens Color |
|--------------|----------|---------------|-------------|
| | Material | Emitted Color | |
| EALP05SXAWA0 | InGaN | White | Water Clear |

Package Dimensions

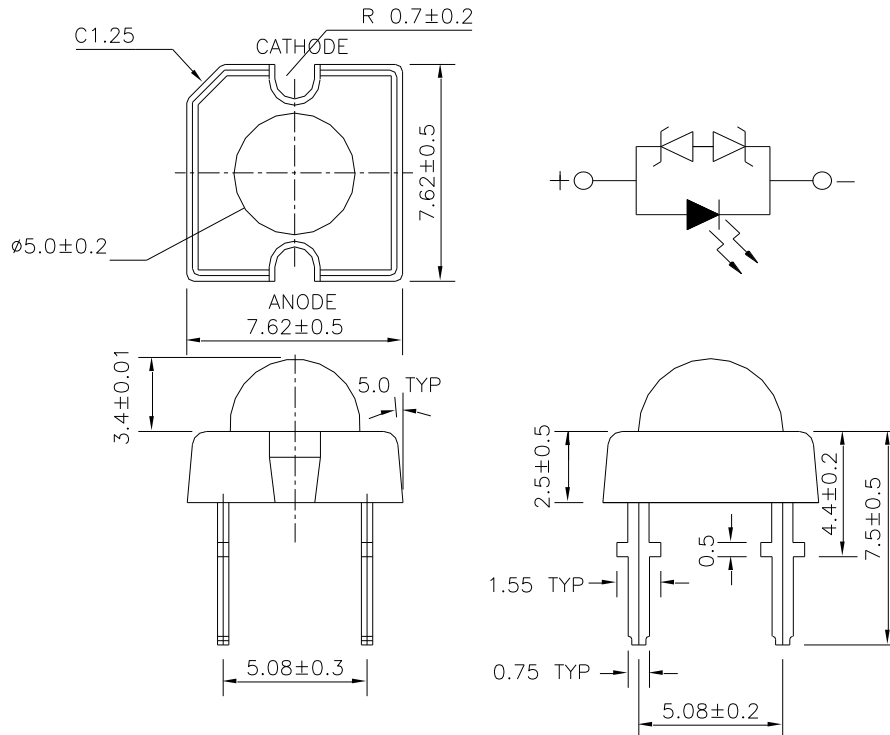

- Notes:**
- 1.All dimensions are in millimeters
 - 2.An epoxy meniscus may extend about 1.5mm(0.059") down the leads
 - 3.Tolerances unless dimensions $\pm 0.25\text{mm}$

Absolute Maximum Ratings ($T_a=25^\circ\text{C}$)

| Parameter | Symbol | Rating | Units |
|--|-----------|-------------|------------------|
| Continuous Forward Current | I_F | 30 | mA |
| Peak Forward Current(Duty 1/10 @ 1KHZ) | I_{FP} | 100 | mA |
| Operating Temperature | T_{opr} | -40 ~ +85 | $^\circ\text{C}$ |
| Storage Temperature | T_{stg} | -40 ~ +100 | $^\circ\text{C}$ |
| Soldering Temperature($T=5$ sec) | T_{sol} | 260 ± 5 | $^\circ\text{C}$ |
| LED Junction Temperature | T_j | 125 | $^\circ\text{C}$ |
| Power Dissipation | P_d | 120 | mW |
| Zener Reverse Current | I_z | 100 | mA |
| Electrostatic Discharge | ESD | 4000 | V |

Electro-Optical Characteristics (Ta=25°C)

| Parameter | Symbol | Min. | Typ. | Max. | Condition | Unit |
|--------------------------|----------------|------|------|------|----------------------|------|
| Forward Voltage | V _F | 2.8 | 3.6 | 4.0 | I _F =30mA | V |
| Reverse Current | I _R | ---- | ---- | 10 | V _R =5V | uA |
| Total Flux | Φ _v | 2850 | 4500 | 5650 | I _F =30mA | mlm |
| Viewing Angle | 2θ 1/2 | ---- | 25 | ---- | I _F =30mA | deg |
| Chromaticity Coordinates | x | ---- | 0.30 | ---- | I _F =30mA | ---- |
| | y | ---- | 0.29 | ---- | | ---- |
| Zener Reverse Voltage | V _Z | 5.2 | ---- | ---- | I _Z =5mA | V |

Rank

35-01/T4C-4PRB

(1)

(2)

(3)

| (1) V _F (V) | | | (2) Color | | | (3) Φ _v (mlm) | | |
|------------------------|------|------|-----------|------|------|--------------------------|------|------|
| Bin. | Min. | Max. | Bin. | Min. | Max. | Bin. | Min. | Max. |
| 0 | 2.80 | 3.00 | A0 | ---- | ---- | P | 2850 | 3600 |
| 1 | 3.00 | 3.20 | B5 | ---- | ---- | Q | 3600 | 4500 |
| 2 | 3.20 | 3.40 | B6 | ---- | ---- | R | 4500 | 5650 |
| 3 | 3.40 | 3.60 | | | | | | |
| 4 | 3.60 | 3.80 | | | | | | |
| 5 | 3.80 | 4.00 | | | | | | |

*Measurement Uncertainty of Forward Voltage : ±0.1V

*Measurement Uncertainty of Total Flux: ±11%

CIE Chromaticity Diagram

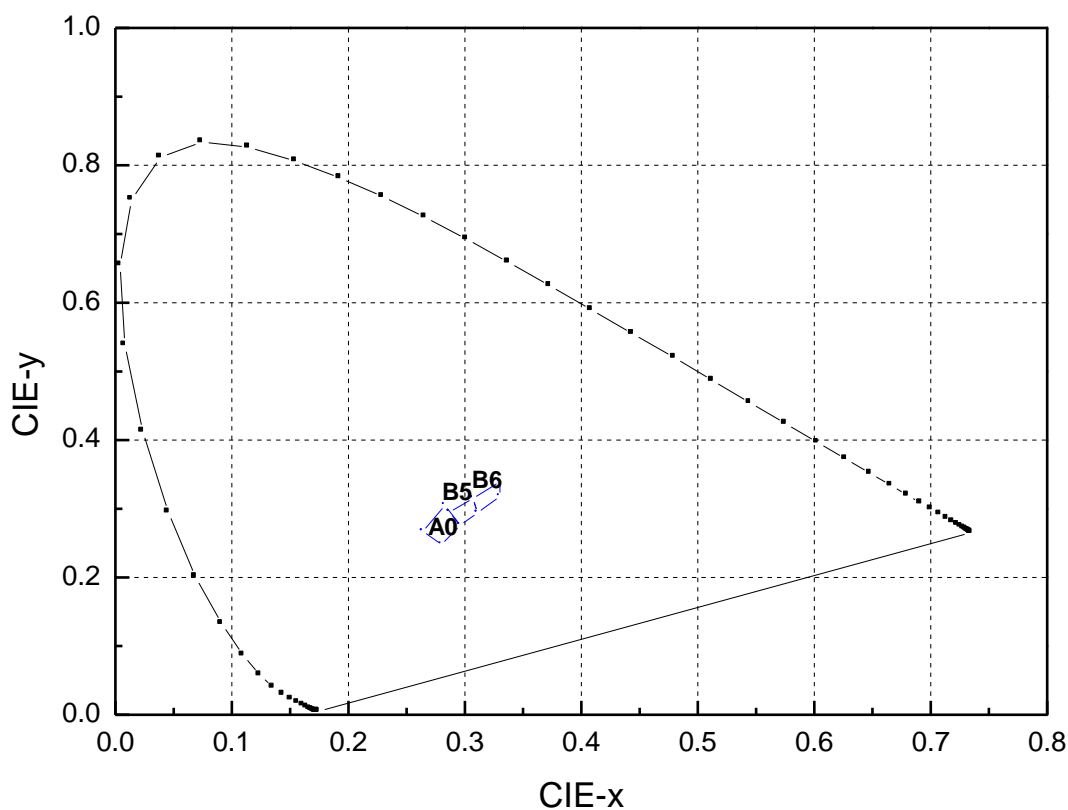

Color Ranks (IF=30mA , Ta=25°C)

| Color Ranks | | CIE | | | |
|-------------|---|-------|-------|-------|-------|
| A0 | X | 0.280 | 0.264 | 0.283 | 0.296 |
| | Y | 0.248 | 0.267 | 0.305 | 0.276 |
| B5 | X | 0.296 | 0.287 | 0.307 | 0.311 |
| | Y | 0.276 | 0.295 | 0.315 | 0.294 |
| B6 | X | 0.311 | 0.307 | 0.330 | 0.330 |
| | Y | 0.294 | 0.315 | 0.339 | 0.318 |

*Measurement uncertainty of the color coordinates : ± 0.01

Typical Electro-Optical Characteristics Curves

Relative Intensity vs. Wavelength

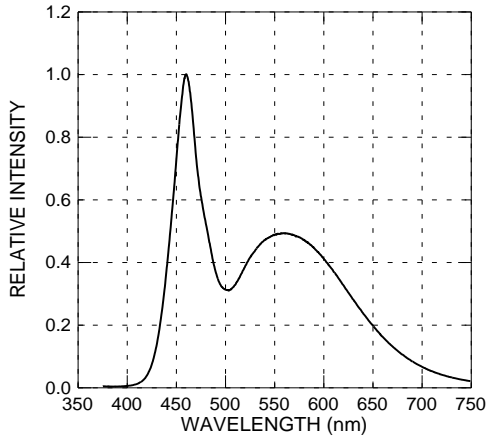

Forward Current vs. Forward Voltage

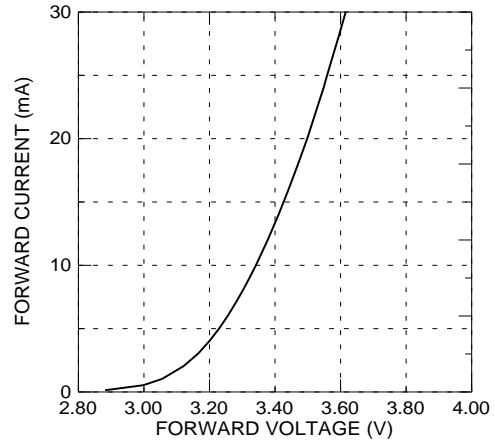

Relative Intensity vs. Forward Current

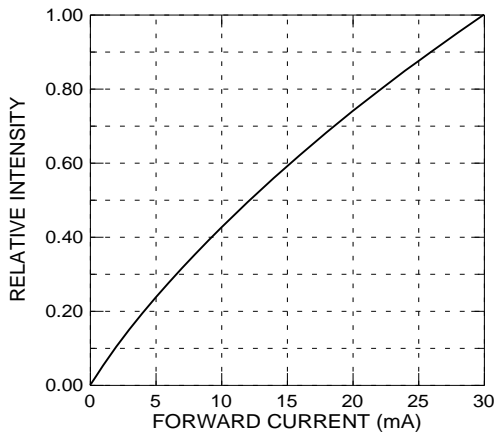

Forward Current vs. Ambient Temp.

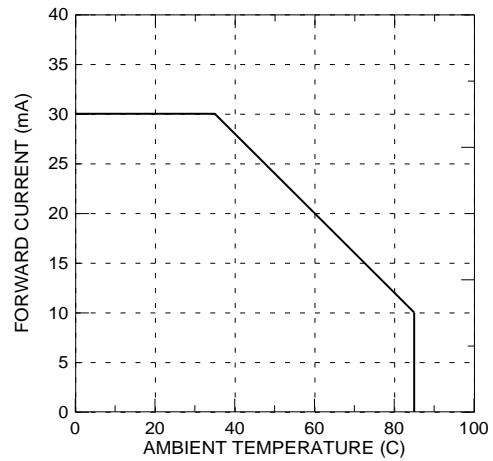

Chromaticity Coordinate vs. Forward Current

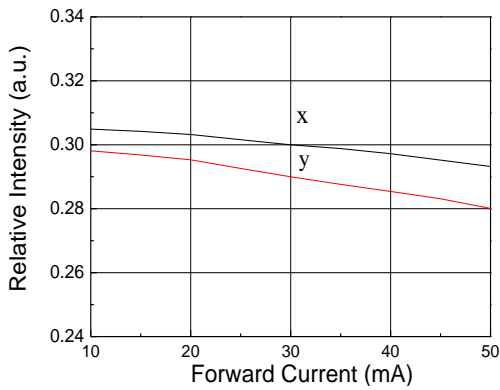

Radiation Characteristics

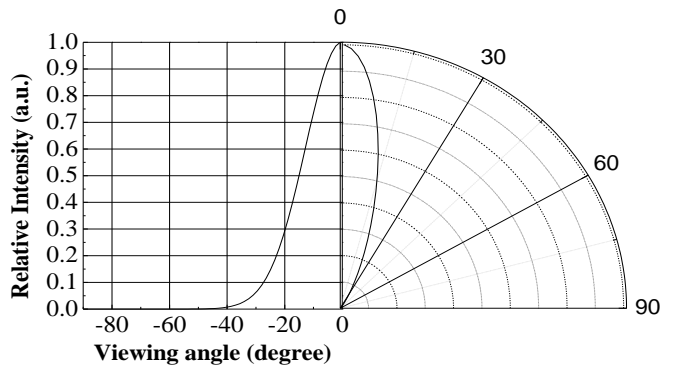

Packing Quantity Specification





- (1) 60 pcs/1 tube, 20 tubes/1 small inside box, 12 small inside boxes/1 outside box
- (2) 60 pcs/1 tube, 80 tubes/1 big inside box, 8 big inside boxes/1 outside box

Label Form Specification

(1)Tube Label Form

| | | |
|---|-------------------------|---------|
|  | PART NO: 35-01/T4C-4PRB | QTY: 60 |
| | LOT NO: | CAT: |

(2)Box Label Form

| | |
|---|--|
|  | |
| CPN: | |
| P/N: | |
|  |  |
| 35-01/T4C-4PRB | |
| QTY : | CAT: |
|  | HUE: |
| LOT NO : | REF: |
|  | |
| MADE IN TAIWAN | |

PART NO: Everlight's Production Number

QTY: Packing Quantity

LOT NO: Lot Number

CAT: Ranks of Forward Voltage, Color Bin Grade and Total Flux

CPN: Customer's Production Number

P/N : Production Number

HUE: Reference

REF: Reference

MADE IN TAIWAN: Production Place

Notes

1. Above specification may be changed without notice. EVERLIGHT AMERICAS will reserve authority on material change for above specification.
2. When using this product, please observe the absolute maximum ratings and the instructions for using outlined in these specification sheets. EVERLIGHT AMERICAS assumes no responsibility for any damage resulting from use of the product which does not comply with the absolute maximum ratings and the instructions included in these specification sheets.
3. These specification sheets include materials protected under copyright of EVERLIGHT AMERICAS corporation. Please don't reproduce or cause anyone to reproduce them without EVERLIGHT AMERICAS's consent.
4. Below the zener reference voltage V_z , all the current flows through LED and as the voltage rises to V_z , the zener diode "breakdown." If the voltage tries to rise above V_z current flows through the zener branch to keep the voltage at exactly V_z .
5. When the LED is connected using serial circuit, if either piece of LED is no light up but current can't flow through causing others to light down. In new design, the LED is parallel with zener diode. if either piece of LED is no light up but current can flow through causing others to light.

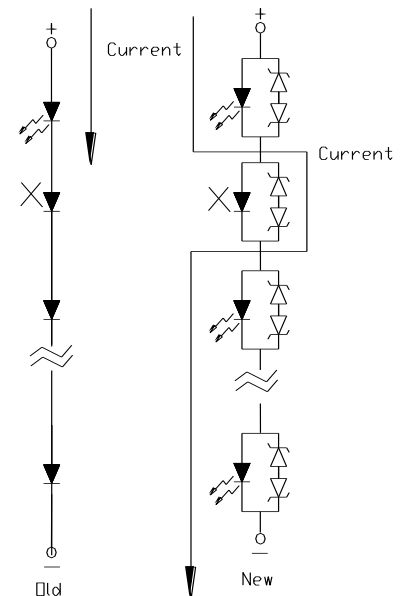

6. Soldering Condition

Careful attention should be paid during soldering. When soldering, leave more than 3mm from solder joint to case, and soldering beyond the base of the tie bar is recommended.

Avoiding applying any stress to the lead frame while the LEDs are at high temperature particularly when soldering.

Recommended soldering conditions:

| Hand Soldering | | DIP Soldering | |
|----------------------|-------------------------------------|---------------|--------------------------|
| Temp. at tip of iron | 400°C Max. (30W Max.) | Preheat temp. | 100°C Max. (60 sec Max.) |
| Soldering time | 3 sec Max. | Bath temp. | 265 Max. |
| Distance | 3mm Min.(From solder joint to case) | Bath time. | 5 sec Max. |
| | | Distance | 3mm Min. |