

EL 3030E

XI3030-PA1501M-AM



Features

- Package: SMD EMC package
- Typical Color : CIE x 0.575 CIE y 0.415 phosphor converted amber
- Typical Luminous Flux: 36 lm @ 150mA
- Viewing angle: 115 °
- ESD : up to 8KV
- MSL : 3
- Qualifications: According to AEC-Q102
- Compliance with RoHS and REACH
- Sulfur robustness

Applications

- Automotive exterior lighting
- Turning Light

Contents

1. Characteristics.....	3
2. Absolute Maximum Ratings.....	4
3. Characteristics Graph.....	5
4. Binning Information.....	10
5. Part Number	13
6. Ordering Information.....	14
7. Mechanical Dimension	15
8. Recommended Soldering Pad	16
9. Reflow Soldering Profile.....	16
10. Packaging Information	17
11. Precaution for Use	19

1. Characteristics

Parameter		Symbol	Min.	Typ.	Max.	Unit	Condition
Forward Current		I_F	50	150	350	mA	---
Luminous Flux ^{[1][2]}		I_v	27	36	45	lm	$I_F=150mA$
Forward Voltage ^{[3][4]}		V_F	2.25	2.9	4.0	V	$I_F=150mA$
Viewing Angle		ϕ	---	115	---	deg	$I_F=150mA$
Chromaticity Coordinates ^[5]		C x		0.575		---	$I_F=150mA$
		C y		0.415		---	$I_F=150mA$
Thermal Resistance (Junction to Solder)	Real	$R_{th JS real}$	---	35.10	---	K/W	$I_F=150mA$
	Electrical	$R_{th JS el}$	---	27.19	---		

Notes:

1. Luminous Flux measurement tolerance: $\pm 8\%$.
2. The data of Luminous Flux measured at thermal pad=25°C
3. Forward voltage measurement tolerance: $\pm 0.05V$
4. The V_F range shown in the table above indicates 99% output.
5. Tolerance of Chromaticity Coordinates x,y : ± 0.005 .

2. Absolute Maximum Ratings

Parameter	Symbol	Ratings	Unit
Power Dissipation	P_d	525	mW
DC Forward Current	I_F	350	mA
Surge current ($t \leq 10 \mu s$; $D=0.005$; $T_s=25^\circ C$)	I_{FM}	2300	mA
Reverse Voltage	V_R	Not designed for reverse operation	V
Junction Temperature	T_J	150	$^\circ C$
Operating Temperature	T_{opr}	-40 ~ +125	$^\circ C$
Storage Temperature	T_{stg}	-40 ~ +125	$^\circ C$
ESD Sensitivity ($R=1.5k\Omega$, $C=100pF$ Condition)	ESD_{HBM}	8	kV
Soldering Temperature	Reflow	260 $^\circ C$ for 30 sec	$^\circ C$

3. Characteristics Graph

Wavelength Characteristics Relative Spectral Distribution
 @ Ts = 25°C , If=150mA

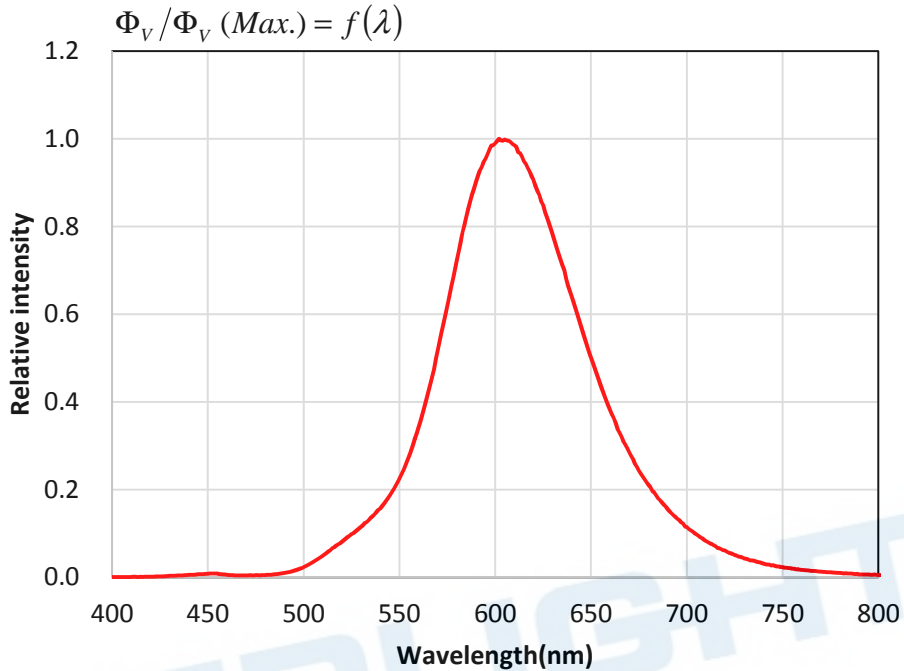

Typical Diagram Characteristics of Radiation

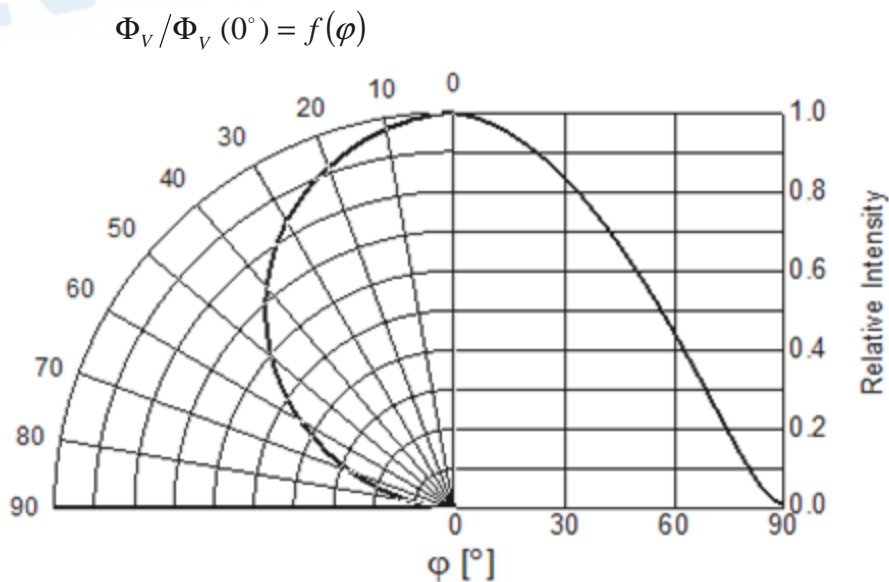

Notes:

1. φ is the off axis angle from lamp centerline where the luminous intensity is 1/2 of the peak value.
2. View angle tolerance is ± 5

Forward Current vs. Forward Voltage @ Ts = 25°C

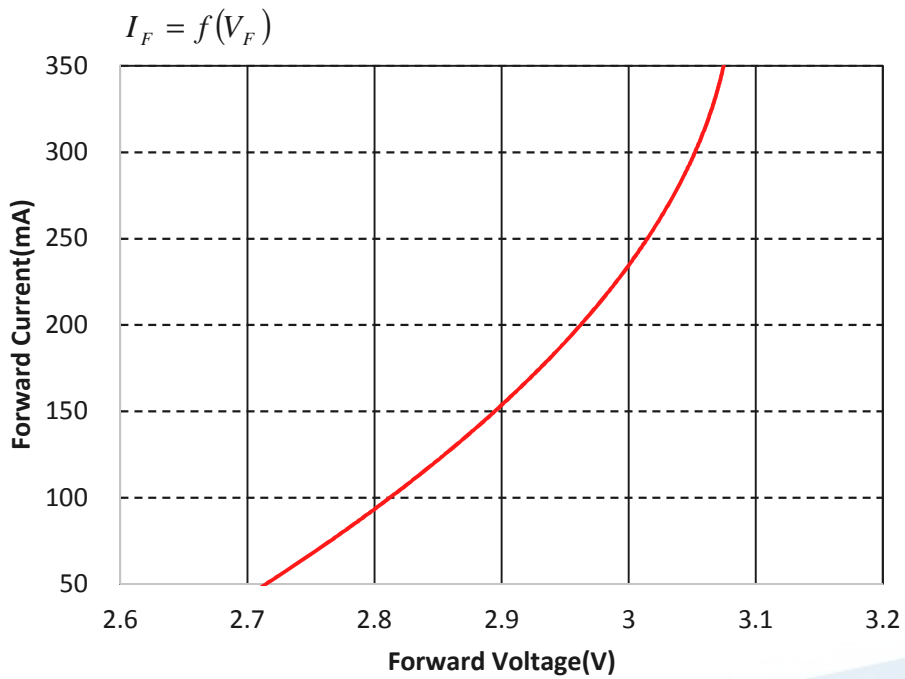

Relative Luminous Flux vs. Forward Current @ Ts = 25°C

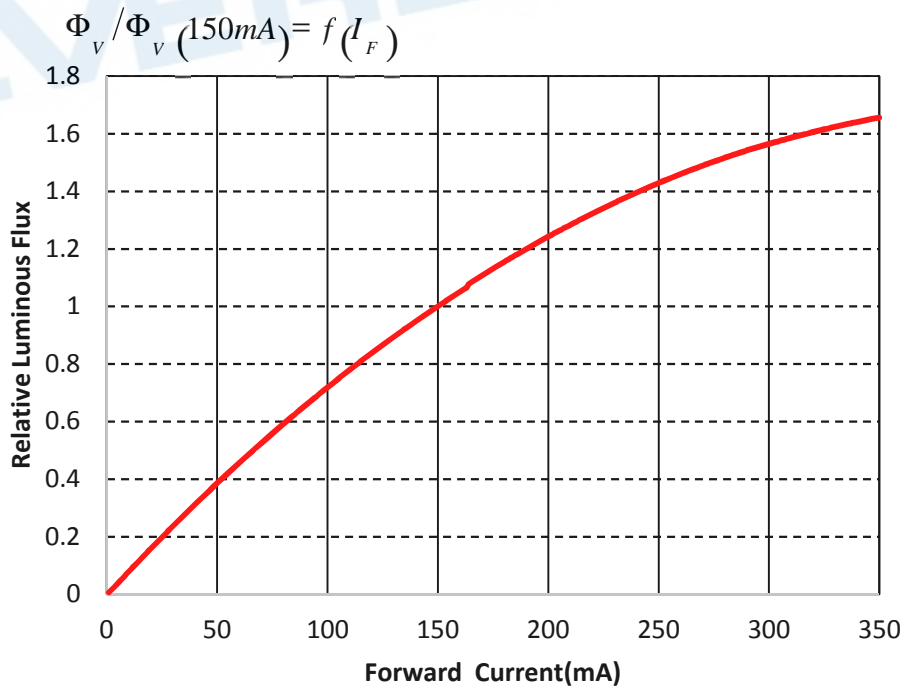

Chromaticity Coordinates Shift vs. Forward Current @ $T_s = 25^\circ\text{C}$

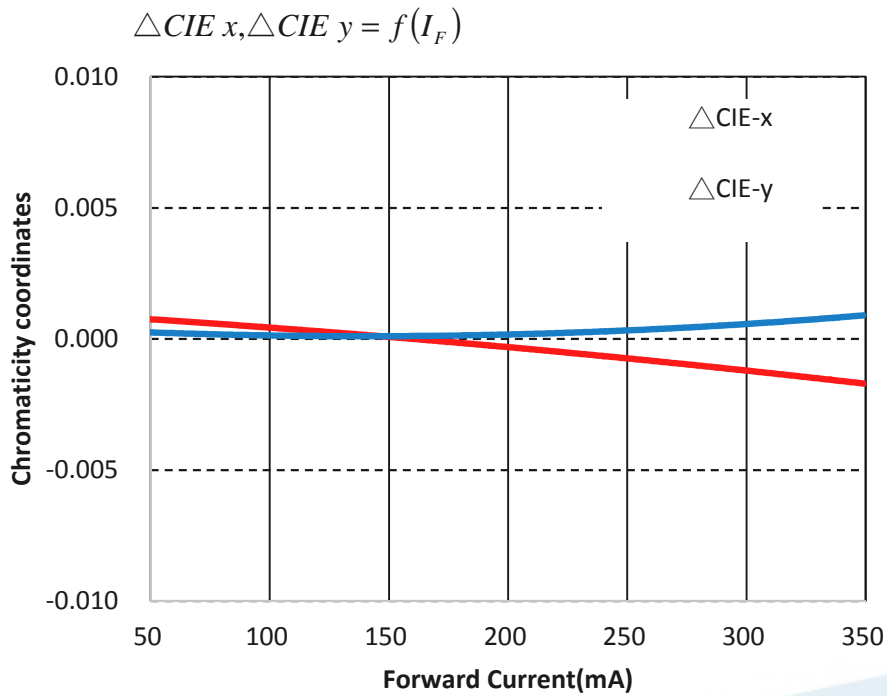

Relative Forward Voltage vs. Junction Temperature @ $I_F = 150\text{mA}$

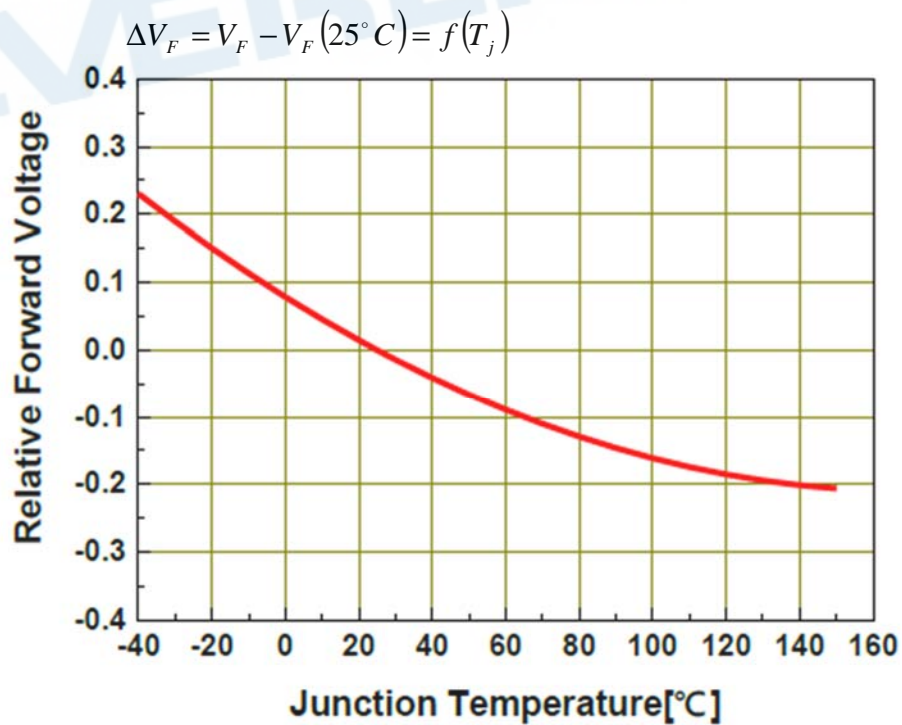

Relative Luminous Flux vs. Junction Temperature
 @ $I_F=150\text{mA}$

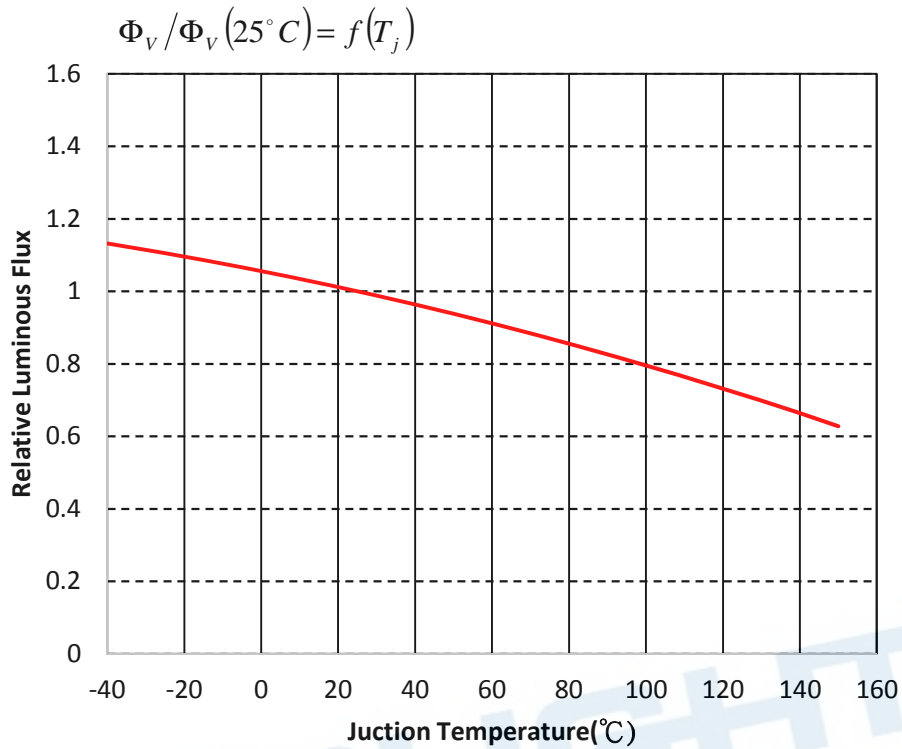

Chromaticity Coordinates Shift vs. Junction Temperature
 @ $I_F=150\text{mA}$

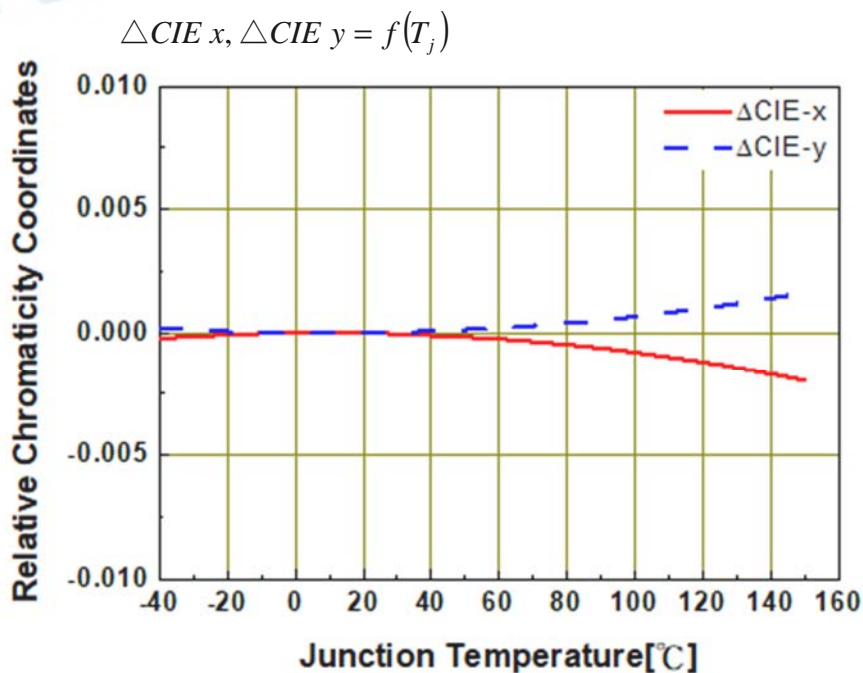

Forward Current Derating Curve @ Soldering Temperature

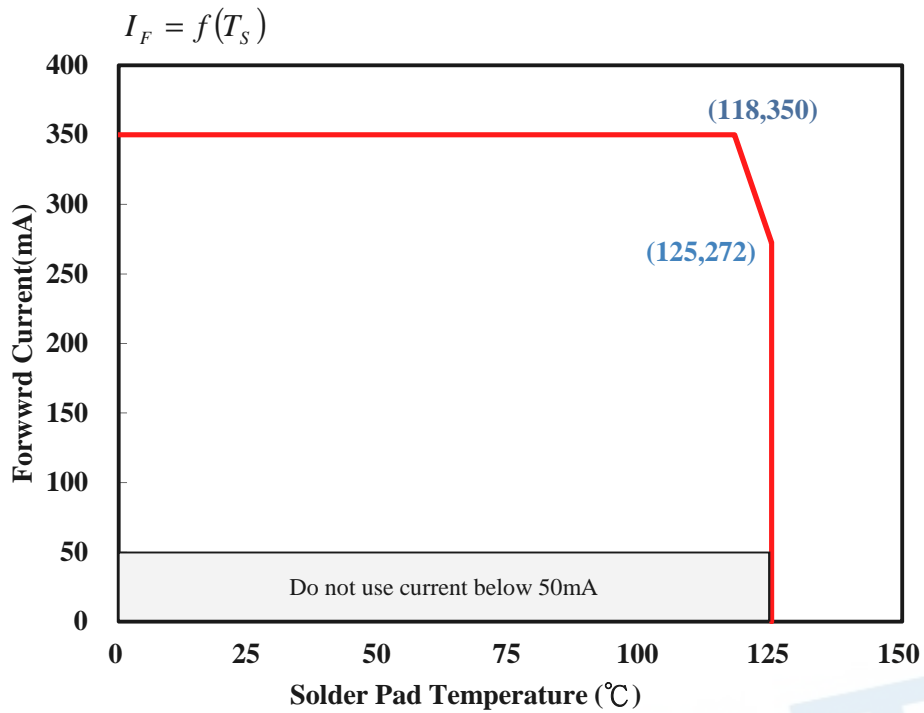

Permissible Pulse Handling Capability

D=Duty cycle , $T_s = 25C$

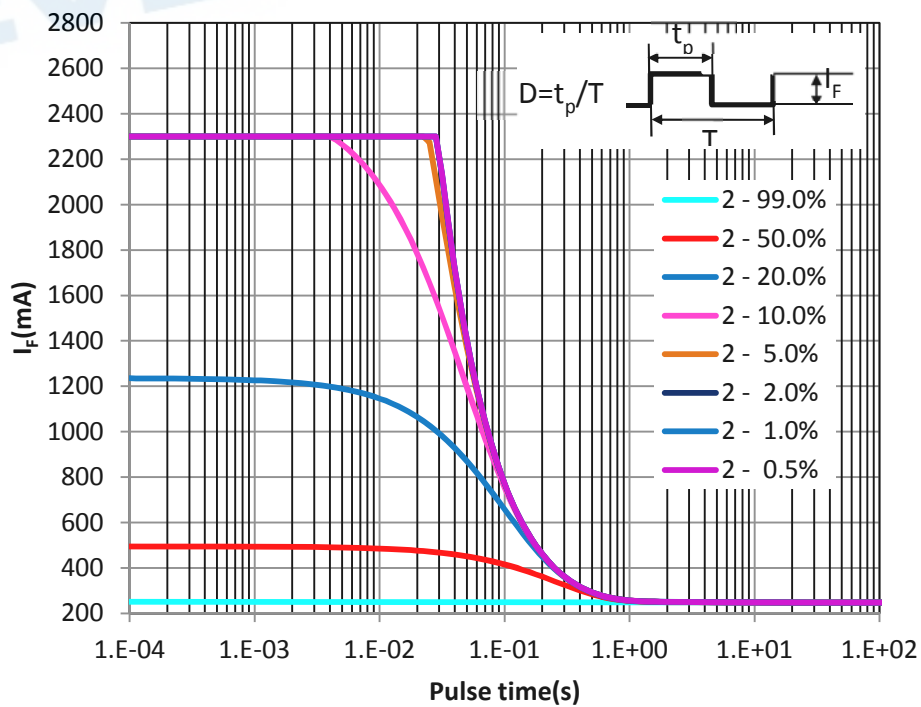

4. Binning Information

Luminous Intensity Bins

Group	Bin	Minimum Photometric Flux (lm)	Maximum Photometric Flux (lm)
E	1	4	5
	2	5	6
	3	6	8
	4	8	10
	5	10	13
	6	13	17
	7	17	20
	8	20	23
	9	23	27
F	1	27	33
	2	33	39
	3	39	45
	4	45	52
	5	52	60
	6	60	70
	7	70	80
	8	80	90
	9	90	100

Group	Bin	Minimum Photometric Flux (lm)	Maximum Photometric Flux (lm)
J	1	100	110
	2	110	120
	3	120	130
	4	130	140
	5	140	150
	6	150	160
	7	160	180
	8	180	200
	9	200	225
K	1	225	250
	2	250	275
	3	275	300
	4	300	325
	5	325	350
	6	350	375
	7	375	400
	8	400	425
	9	425	450

Notes:

1. Luminous Intensity measurement tolerance: $\pm 8\%$.

**Product Binning Color Bin Structure
ECE Bin Structure**

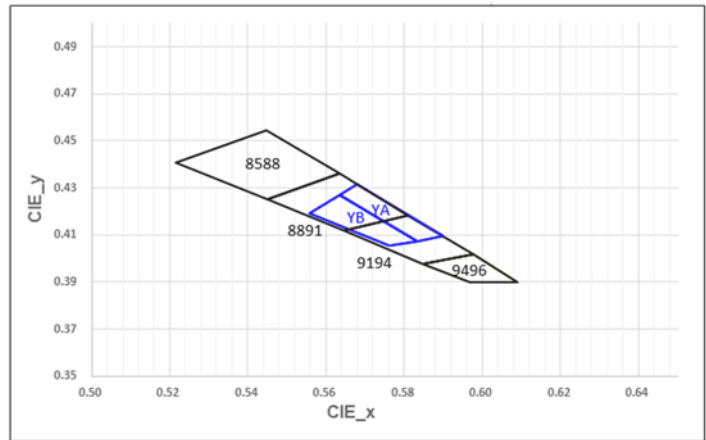
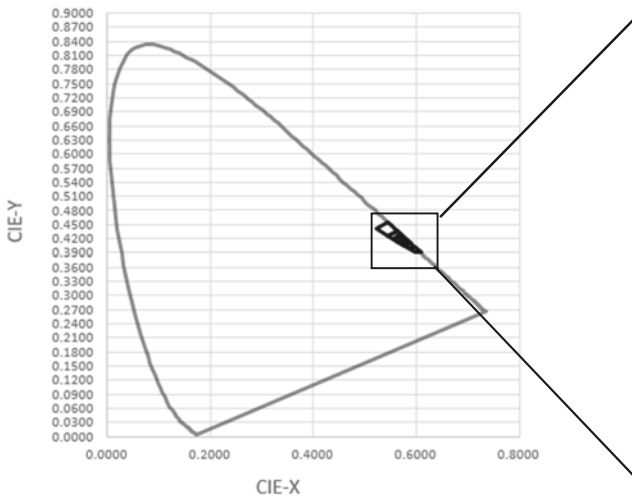

ECE Phosphor Yellow Bin Coordinates

Bin Code	CIE_x	CIE_y	Bin Code	CIE_x	CIE_y
YA	0.5680	0.4315	YB	0.5763	0.4054
	0.5634	0.4269		0.5833	0.4075
	0.5833	0.4075		0.563	0.427
	0.5901	0.4094		0.5557	0.4192
8588	0.5215	0.4406	8891	0.5636	0.4362
	0.5448	0.4544		0.581	0.4184
	0.5636	0.4362		0.5646	0.4119
	0.545	0.425		0.545	0.425
9194	0.5646	0.4119	9496	0.5848	0.3979
	0.581	0.4184		0.5977	0.4018
	0.5977	0.4018		0.609	0.39
	0.5848	0.3979		0.597	0.39

Notes:

1. Color coordinates measurement allowance: ± 0.005

Forward Voltage Bins

Bin	Minimum Forward Voltage [V]	Maximum Forward Voltage [V]
1012	1.00	1.25
1215	1.25	1.75
1517	1.50	1.75
1720	1.75	2.00
2022	2.00	2.25
2225	2.25	2.50
2527	2.50	2.75
2730	2.75	3.00
3032	3.00	3.25
3235	3.25	3.50
3537	3.50	3.75
3740	3.75	4.00
4042	4.00	4.25
4245	4.25	4.50
4547	4.50	4.75
4750	4.75	5.00
5052	5.00	5.25
5255	5.25	5.50
5557	5.50	5.75
5760	5.75	6.00
6062	6.00	6.25
6265	6.25	6.50
6567	6.50	6.75
6770	6.75	7.00

Notes:

1. Forward voltage measurement tolerance: $\pm 0.05V$.
2. Forward voltage bins are defined at $I_F = 150mA$ operation.

5. Part Number

XI3030-PA1501M-AM

Part number is designated with below details.

XI3030 = product family name.

PA = color [1]

150 = Test current [mA]

1 = Lead Frame Type (0=Ag ; 1=Au; 2=MLP)

H = Brightness Level (H=High ; M=Medium ; L=Low)

AM = Automotive Application

Note

[1] Color :

Symbol	Description
C	Cool White
N	Neutral White
W	Warm White
PA	Phosphor Converted Amber
PR	Phosphor Converted Red
UB	Blue
IB	Ice Blue
SB	Sky Blue
UP	Purple
UG	Green
UY	Yellow
UA	Amber
UR	Red
SR	Super Red
RGB	RGB – Color
RGBY	RGBY – Color

6. Ordering Information

Part Number of the EL 3030E	Order Code
XI3030-PA1501M-AM	XI3030-PA1501M-YAYBF1F32240-2T-AM

Order code contains information with below details :

ABCD = min/max wavelength or CCT

EFGH = min./max. luminous flux in [lm] or luminous intensity in [mcd]

IJKL = min./max. forward voltage

MO = internal code

EVERLIGHT

7. Mechanical Dimension

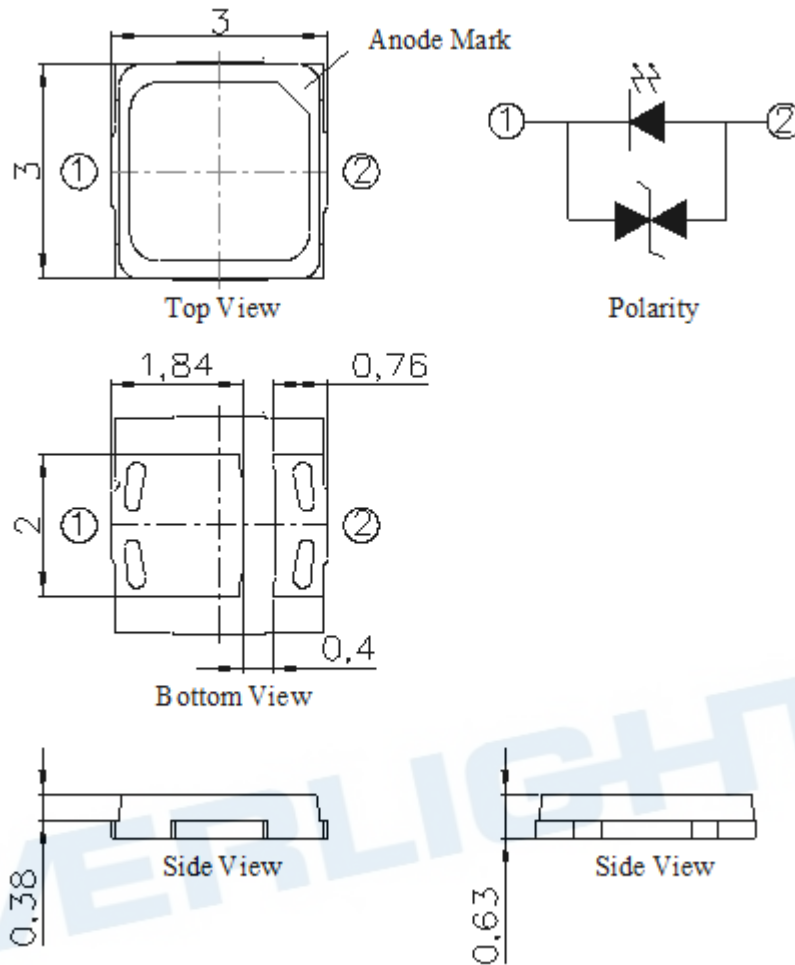

Notes:

1. Dimensions are in millimeters.
2. Tolerances unless mentioned are ± 0.1 mm.

7. Recommended Soldering Pad

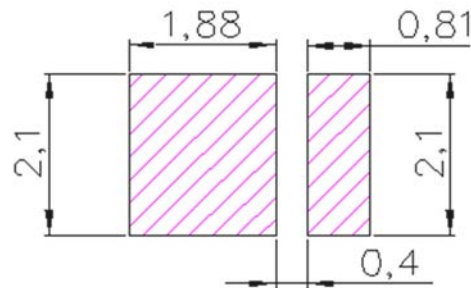

9. Reflow Soldering Profile

Soldering Condition (Reference: IPC/JEDEC J-STD-020D)

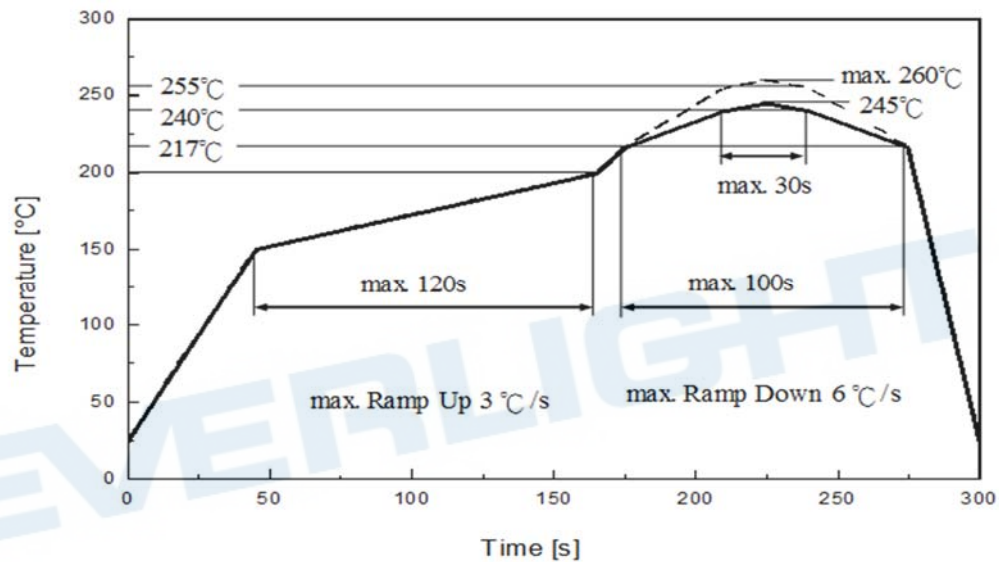

Profile Feature	Pb-Free Assembly	Unit Einheit
	Recommendation	
Ramp-up rate to preheat 25 °C to 150 °C	3	°C /sec
Time of soaking zone 150 °C to 200 °C	120	sec
Ramp-up rate to peak	3	°C /sec
Liquidus temperature	217	°C
Time above liquidus temperature	100	sec
Peak temperature (max.)	260	°C
Time within 5°C of the specified peak temperature	30	sec
Ramp-down Rate (max.)	6	°C /sec

10. Packaging Information

● Product Labeling



- CPN : Customer's Product Number
- P/N : Everlight Part Number
- QTY : Packing Quantity
- CAT : Luminous Flux (Brightness) Bin
- HUE : Color Bin
- REF : Forward Voltage Bin
- LOT No : Lot Number

● Packing: Loaded Quantity 2000 pcs Per Reel

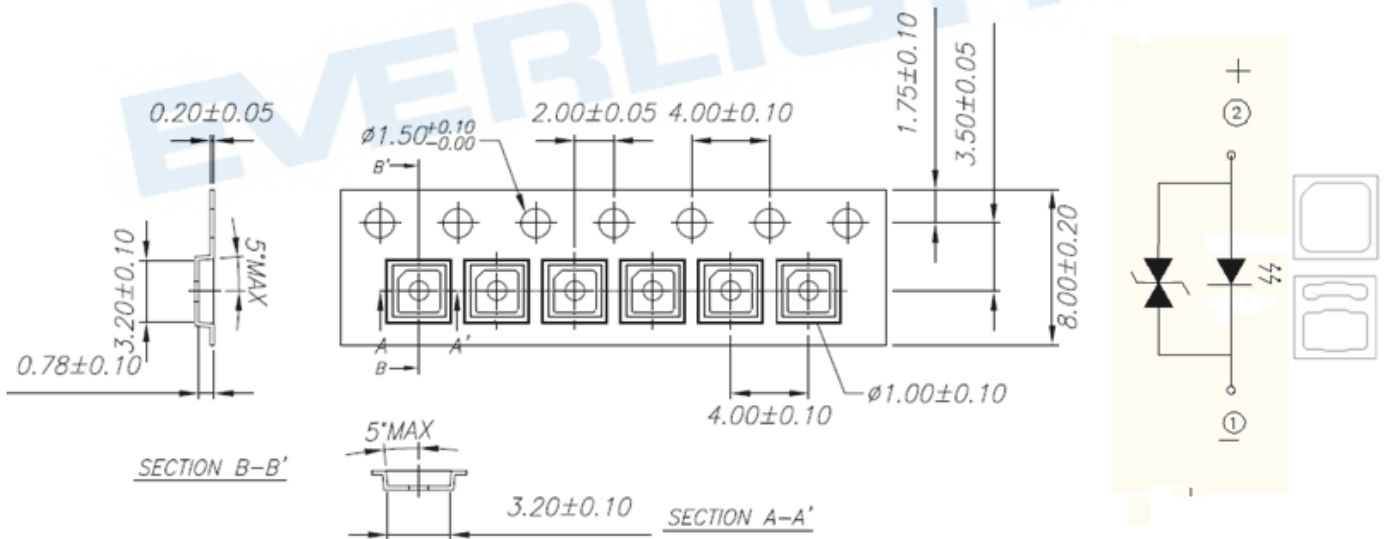

Notes:

1. Dimensions are in millimeters.

● **Reel Dimensions**

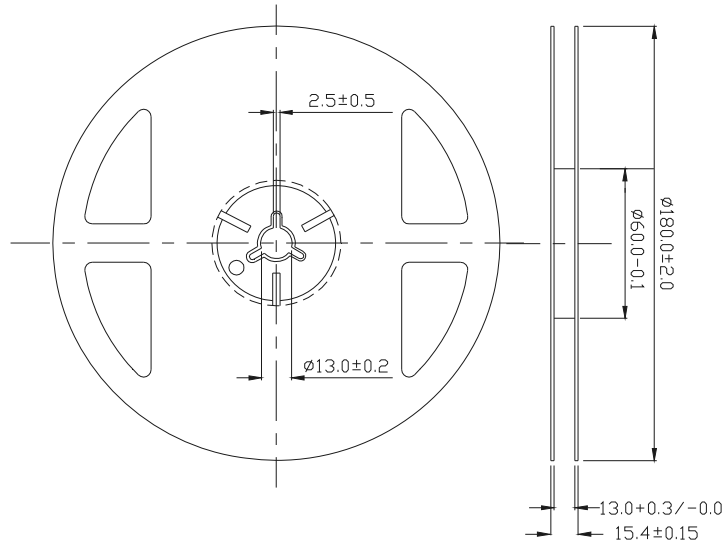

Notes:

1. Dimensions are in millimeters.

● **Moisture Resistant Packing Process**

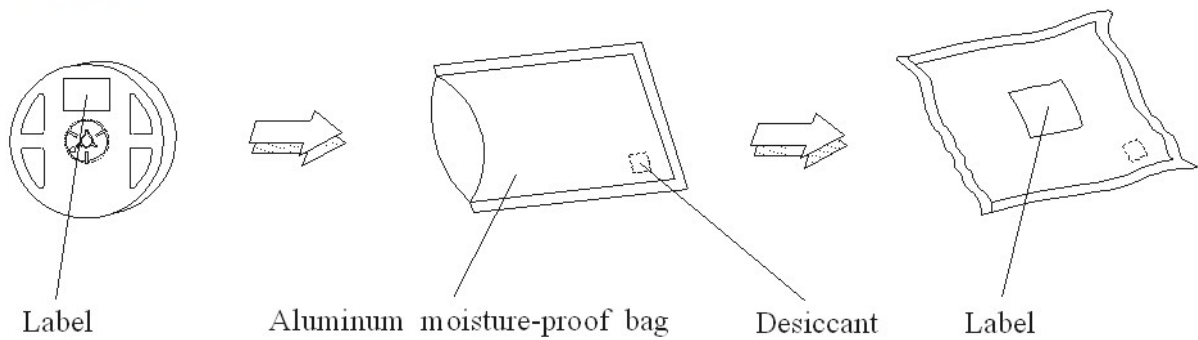

11. Precaution for Use

1. Over-current-proof

Customer must apply resistors for protection; otherwise slight voltage shift will cause big current change (burn out will happen).

2. Assemblies

Do not stack assemblies containing LEDs to prevent damage to the optical surface of LEDs. Forces applied to the optical surface may result in the surface being damaged.

3. Soldering Condition

3.1 When soldering, do not put stress on the LEDs during heating.

3.2 After soldering, do not warp the circuit board.

4. Soldering Iron

Each terminal is to go to the tip of soldering iron temperature less than 350°C for 3 seconds within once in less than the soldering iron capacity 25W. Leave two seconds and more intervals, and do soldering of each terminal. Be careful because the damage of the product is often started at the time of the hand solder.

5. Repairing

Repair should not be done after the LEDs have been soldered. When repairing is unavoidable, a double-head soldering iron should be used (as below figure). It should be confirmed beforehand whether the characteristics of the LEDs will or will not be damaged by repairing.

