

EL 3030E XI3030-C01501M-AM

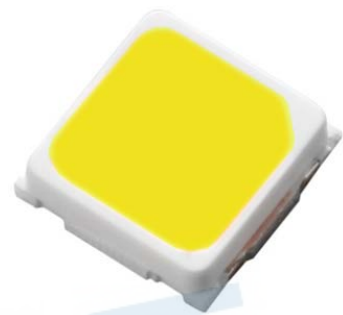

Features

- Package : SMD EMC package
- Color Temperature range : 5180 K ~ 6680 K
- Typical Luminous Flux : 50 lm @ 150mA
- Viewing angle : 120 °
- ESD : up to 8KV
- MSL : 2
- Qualifications : According to AEC-Q102
- Compliance with RoHS and REACH
- Sulfur robustness
- Compliance Halogen Free. (Br <900 ppm ,Cl <900 ppm , Br+Cl < 1500 ppm).

Applications

- Automotive exterior lighting
- Day Time Running Light(DRL)

Contents

1. Characteristics.....	3
2. Absolute Maximum Ratings.....	4
3. Characteristics Graph.....	5
4. Binning Information.....	10
5. Part Number.....	14
6. Ordering Information.....	15
7. Mechanical Dimension.....	16
8. Recommended Soldering Pad.....	17
9. Reflow Soldering Profile.....	17
10. Packaging Information.....	18
11. Precaution for Use.....	20

1. Characteristics

Parameter	Symbol	Min.	Typ.	Max.	Unit	Condition	
Forward Current	I_F	50	150	350	mA	---	
Luminous Flux ^{[1][2]}	I_v	45	50	70	lm	$I_F=150\text{mA}$	
Forward Voltage ^{[3][4]}	V_F	2.5	3.0	3.5	V	$I_F=150\text{mA}$	
Viewing Angle	ϕ	---	120	---	deg	$I_F=150\text{mA}$	
Color Temperature	CCT	5180	5850	6680	K	$I_F=150\text{mA}$	
Thermal Resistance (Junction to Solder)	Real	$R_{th JS real}$	---	22	---	K/W	$I_F=150\text{mA}$
	Electrical	$R_{th JS el}$	---	13	---		

Notes:

1. Luminous Flux measurement tolerance: $\pm 8\%$.
2. The data of Luminous Flux measured at thermal pad=25°C.
3. Forward voltage measurement tolerance: $\pm 0.05\text{V}$.
4. The V_F range shown in the table above indicates 99% output.

2. Absolute Maximum Ratings

Parameter	Symbol	Ratings	Unit
Power Dissipation	P_d	1225	mW
Max. DC Forward Current	I_F	350	mA
Surge current ($t \leq 10 \mu s$; $D=0.005$; $T_s=25^\circ C$)	I_{FM}	1000	mA
Reverse Voltage	V_R	Not designed for reverse operation	V
Junction Temperature	T_J	150	$^\circ C$
Operating Temperature	T_{opr}	-40 ~ +125	$^\circ C$
Storage Temperature	T_{stg}	-40 ~ +125	$^\circ C$
ESD Sensitivity ($R=1.5k\Omega$, $C=100pF$ Condition)	ESD_{HBM}	8	kV
Soldering Temperature	Reflow	260 $^\circ C$ for 30 sec	$^\circ C$

EVERLIGHT

3.Characteristics Graph

Wavelength Characteristics Relative Spectral Distribution @ Ts = 25°C, If=150mA

$$\Phi_v / \Phi_v (Max.) = f(\lambda)$$

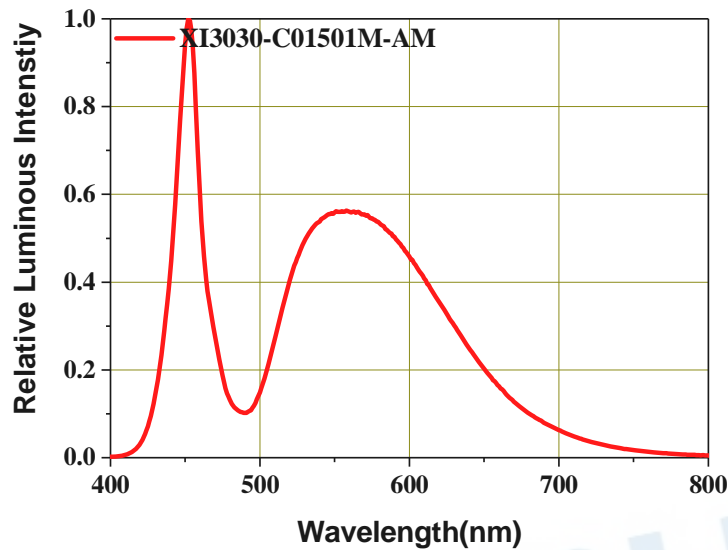

Typical Diagram Characteristics of Radiation

$$\Phi_v / \Phi_v (0^\circ) = f(\varphi)$$

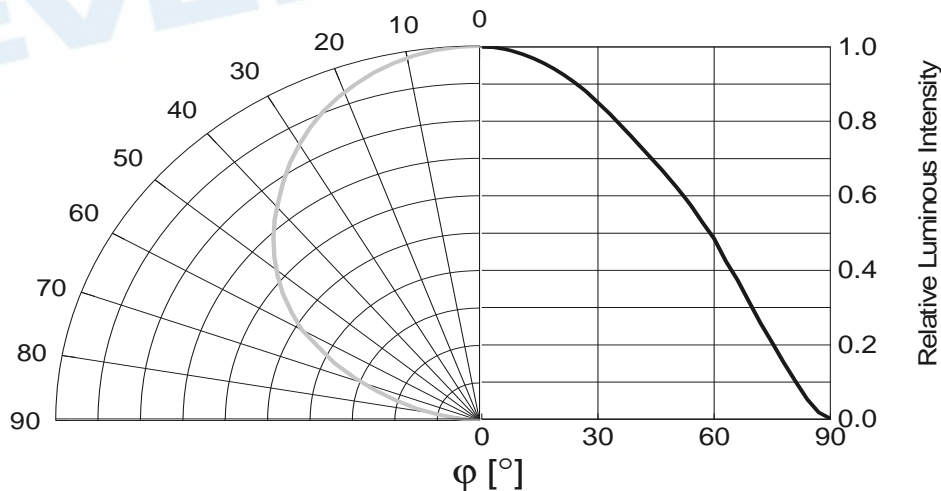

Notes:

1. φ is the off axis angle from lamp centerline where the luminous intensity is 1/2 of the peak value.
2. View angle tolerance is ± 5

Forward Current vs. Forward Voltage
@ Ts = 25°C

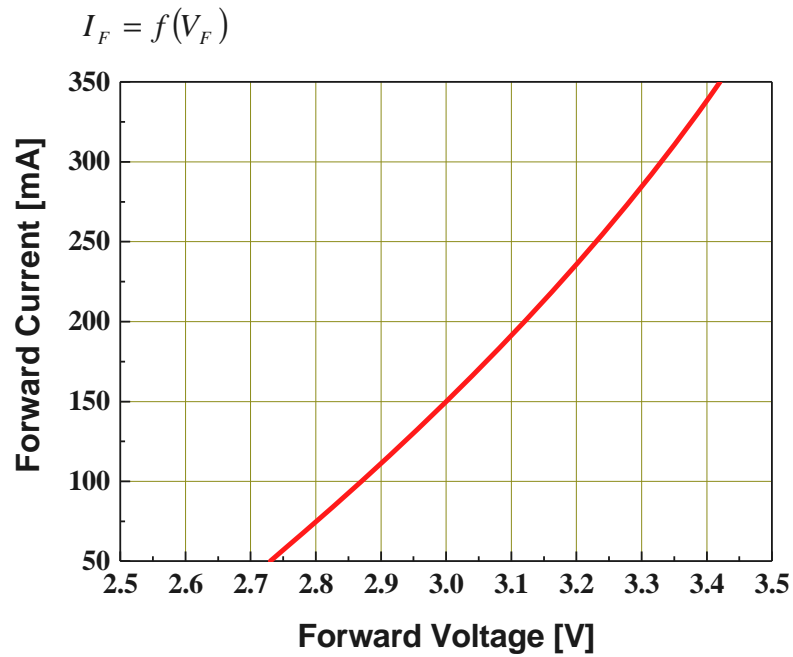

Relative Luminous Flux vs. Forward Current
@ Ts = 25°C

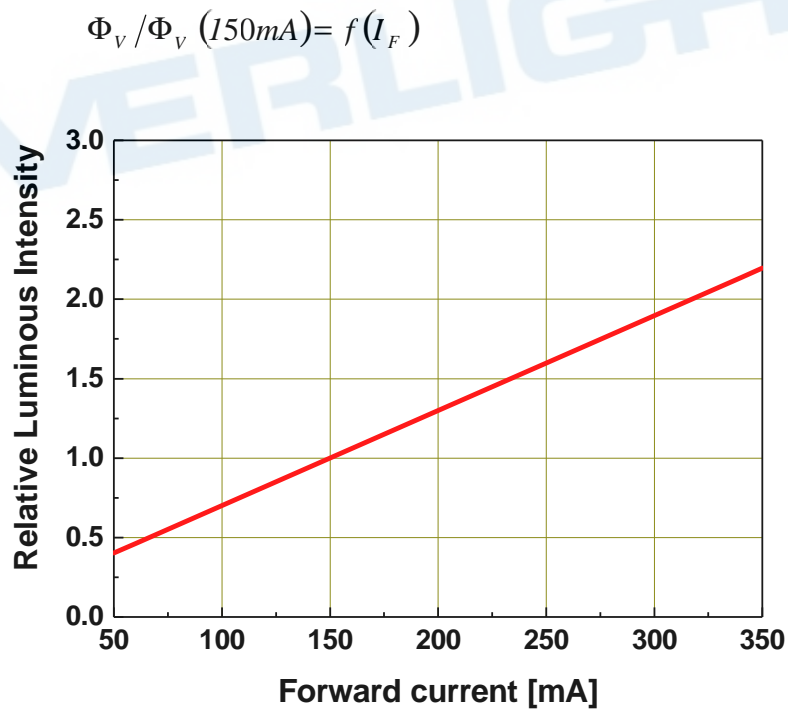

Chromaticity Coordinates Shift vs. Forward Current
@ Ts = 25°C

$$\Delta CIE\ x, \Delta CIE\ y = f(I_F)$$

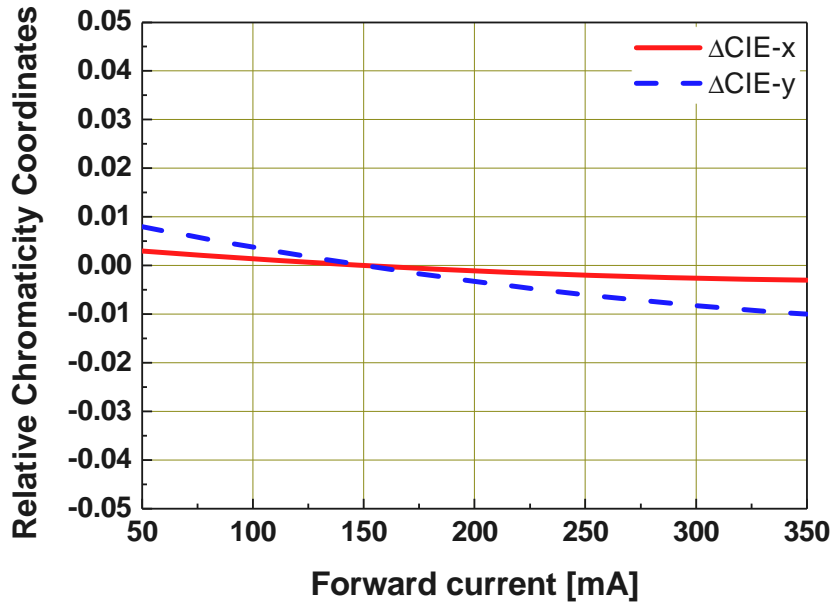

Relative Forward Voltage vs. Junction Temperature
@ IF=150mA

$$\Delta V_F = V_F - V_F(25^\circ C) = f(T_j)$$

Relative Luminous Flux vs. Junction Temperature

@ I_F=150mA

$$\Phi_v / \Phi_v(25^\circ C) = f(T_j)$$

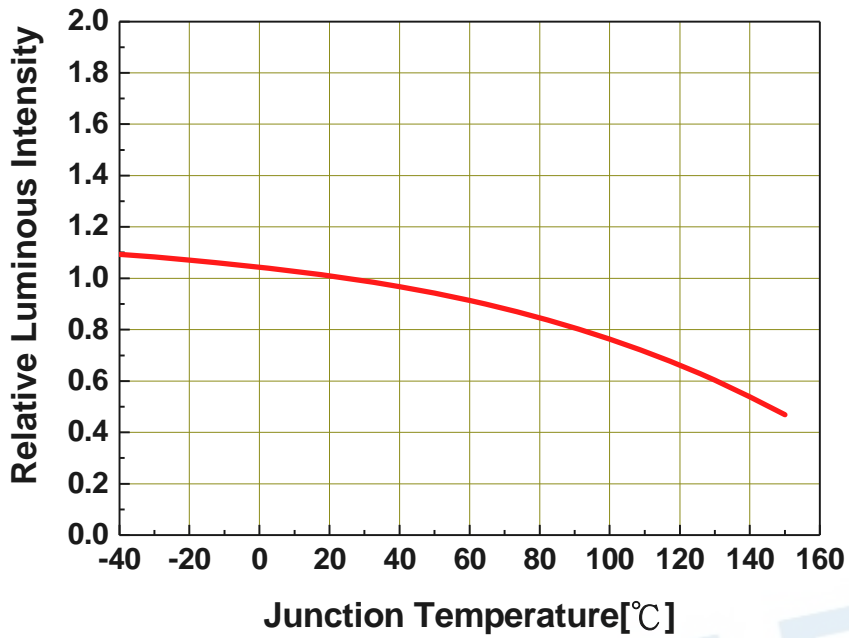

Chromaticity Coordinates Shift vs. Junction Temperature

@ I_F=150mA

$$\Delta CIE x, \Delta CIE y = f(T_j)$$

Forward Current Derating Curve

$$I_F = f(T_S)$$

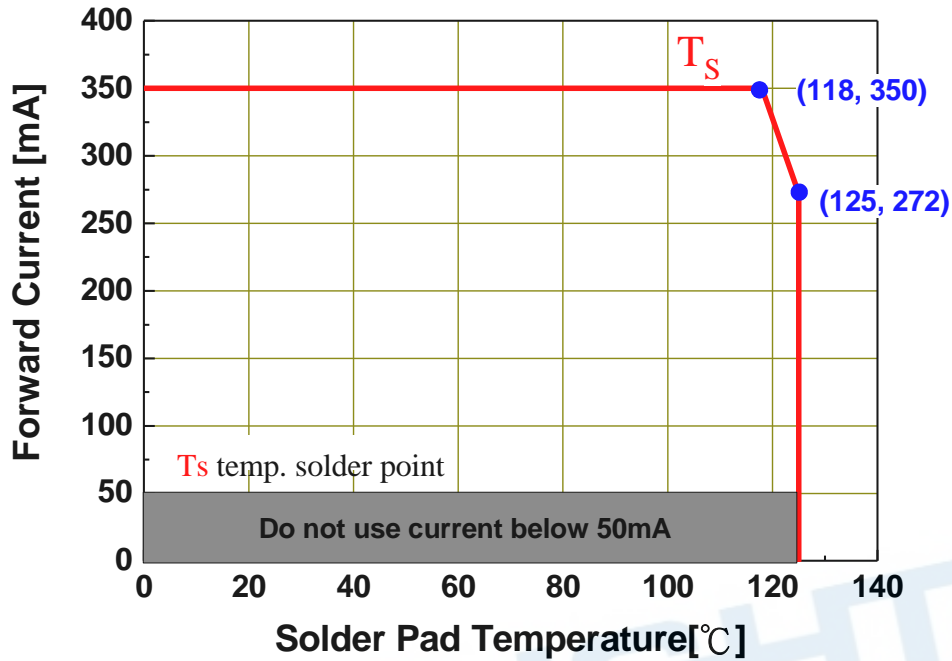

Permissible Pulse Handling Capability

D=Duty cycle , $T_s = 25^\circ\text{C}$

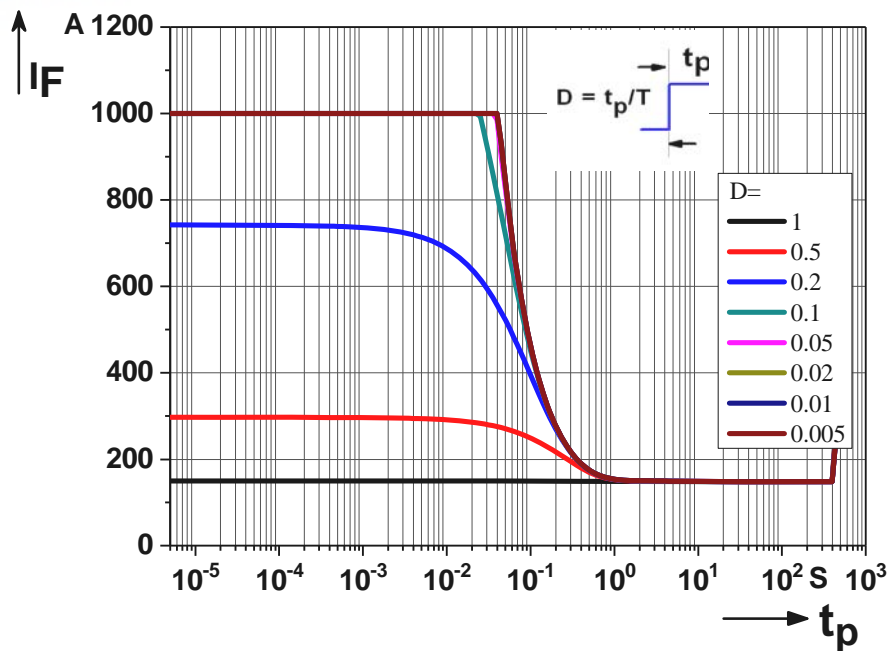

4. Binning Information

Luminous Flux Bins

Group	Bin	Minimum Photometric Flux (lm)	Maximum Photometric Flux (lm)
E	1	4	5
	2	5	6
	3	6	8
	4	8	10
	5	10	13
	6	13	17
	7	17	20
	8	20	23
	9	23	27
F	1	27	33
	2	33	39
	3	39	45
	4	45	52
	5	52	60
	6	60	70
	7	70	80
	8	80	90
	9	90	100

Group	Bin	Minimum Photometric Flux (lm)	Maximum Photometric Flux (lm)
J	1	100	110
	2	110	120
	3	120	130
	4	130	140
	5	140	150
	6	150	160
	7	160	180
	8	180	200
	9	200	225
K	1	225	250
	2	250	275
	3	275	300
	4	300	325
	5	325	350
	6	350	375
	7	375	400
	8	400	425
	9	425	450

Notes:

1. Luminous flux measurement tolerance: $\pm 8\%$.

Product Binning Color Bin Structure
ECE Bin Structure

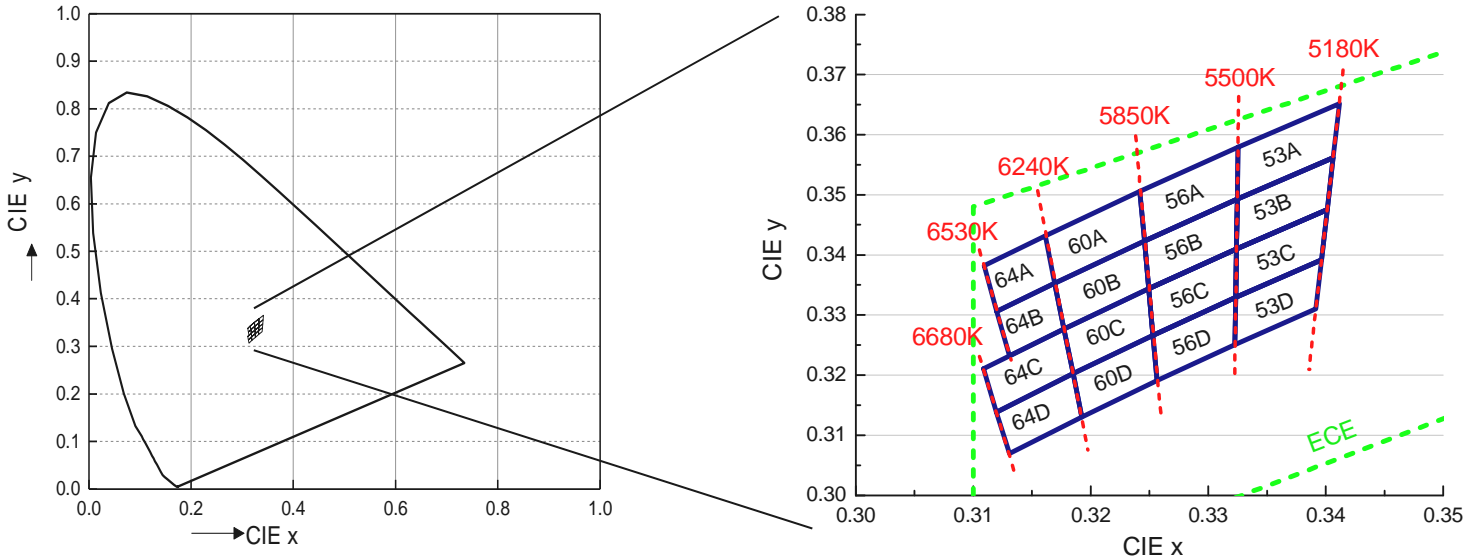

Cool White Bin Coordinates

Bin	CIE x	CIE y
64A	0.3109	0.3382
	0.3161	0.3432
	0.3169	0.3353
	0.3120	0.3306
Reference Range: 6240~6530K		

Bin	CIE x	CIE y
64B	0.3120	0.3306
	0.3169	0.3353
	0.3177	0.3277
	0.3131	0.3232
Reference Range: 6240~6530K		

Bin	CIE x	CIE y
64C	0.3109	0.3211
	0.3177	0.3277
	0.3185	0.3203
	0.3120	0.3139
Reference Range: 6240~6680K		

Bin	CIE x	CIE y
64D	0.3120	0.3139
	0.3185	0.3203
	0.3192	0.3131
	0.3131	0.3070
Reference Range: 6240~6680K		

Bin	CIE x	CIE y
60A	0.3161	0.3432
	0.3242	0.3506
	0.3246	0.3424
	0.3169	0.3353
Reference Range: 5850~6240K		

Bin	CIE x	CIE y
60B	0.3169	0.3353
	0.3246	0.3424
	0.3249	0.3344
	0.3177	0.3277
Reference Range: 5850~6240K		

Cool White Bin Coordinates

Bin	CIE x	CIE y
60C	0.3177	0.3277
	0.3249	0.3344
	0.3253	0.3266
	0.3185	0.3203
Reference Range: 5850~6240K		

Bin	CIE x	CIE y
60D	0.3185	0.3203
	0.3253	0.3266
	0.3256	0.3191
	0.3192	0.3131
Reference Range: 5850~6240K		

Bin	CIE x	CIE y
56A	0.3242	0.3506
	0.3325	0.3579
	0.3325	0.3493
	0.3246	0.3424
Reference Range: 5500~5850K		

Bin	CIE x	CIE y
56B	0.3246	0.3424
	0.3325	0.3493
	0.3324	0.3410
	0.3249	0.3344
Reference Range: 5500~5850K		

Bin	CIE x	CIE y
56C	0.3249	0.3344
	0.3324	0.3410
	0.3323	0.3329
	0.3253	0.3266
Reference Range: 5500~5850K		

Bin	CIE x	CIE y
56D	0.3253	0.3266
	0.3323	0.3329
	0.3323	0.3251
	0.3256	0.3191
Reference Range: 5500~5850K		

Bin	CIE x	CIE y
53A	0.3325	0.3579
	0.3412	0.3652
	0.3406	0.3562
	0.3325	0.3493
Reference Range: 5180~5500K		

Bin	CIE x	CIE y
53B	0.3325	0.3493
	0.3406	0.3562
	0.3401	0.3476
	0.3324	0.3410
Reference Range: 5180~5500K		

Bin	CIE x	CIE y
53C	0.3324	0.3410
	0.3401	0.3476
	0.3396	0.3392
	0.3323	0.3329
Reference Range: 5180~5500K		

Bin	CIE x	CIE y
53D	0.3323	0.3329
	0.3396	0.3392
	0.3392	0.3310
	0.3323	0.3251
Reference Range: 5180~5500K		

Notes: 1. Color coordinates measurement allowance: ± 0.005

Forward Voltage Bins

Bin	Minimum Forward Voltage [V]	Maximum Forward Voltage [V]
1012	1.00	1.25
1215	1.25	1.75
1517	1.50	1.75
1720	1.75	2.00
2022	2.00	2.25
2225	2.25	2.50
2527	2.50	2.75
2730	2.75	3.00
3032	3.00	3.25
3235	3.25	3.50
3537	3.50	3.75
3740	3.75	4.00
4042	4.00	4.25
4245	4.25	4.50
4547	4.50	4.75
4750	4.75	5.00
5052	5.00	5.25
5255	5.25	5.50
5557	5.50	5.75
5760	5.75	6.00
6062	6.00	6.25
6265	6.25	6.50
6567	6.50	6.75
6770	6.75	7.00

Notes:

1. Forward voltage measurement tolerance: $\pm 0.05V$...
2. Forward voltage bins are defined at $I_F = 150mA$ operation..

5.Part Number

XI3030-C01501M-AM

Part number is designated with below details.

XI3030 = Product family name.

C = Color [1]

0 = CRI (0=N/A ; >70=7 ; >80=8 ; >90=9)

150 = Test current [mA]

1 = Lead Frame Type (0=Ag ; 1= Au: 2=MLP)

H = Brightness Level (H=High ; M=Medium ; L=Low)

AM = Automotive Application

Note

[1] Color :

Symbol	Description
C	Cool White
N	Neutral White
W	Warm White
PA	Phosphor Converted Amber
PR	Phosphor Converted Red
UB	Blue
IB	Ice Blue
SB	Sky Blue
UP	Purple
UG	Green
UY	Yellow
UA	Amber
UR	Red
SR	Super Red
RGB	RGB – Color
RGBY	RGBY – Color

6. Ordering Information

Part Number of the EL 3030E	Order Code
XI3030-C01501M-AM	XI3030-C01501M-53A64DF4F62535-2T-AM

Order code contains information with below details :

ABCDEF = min/max wavelength or CCT

GHJK = min./max. luminous flux in [lm] or luminous intensity in [mcd]

LMNO = min./max. forward voltage

PQ = internal code

EVERLIGHT

7.Mechanical Dimension

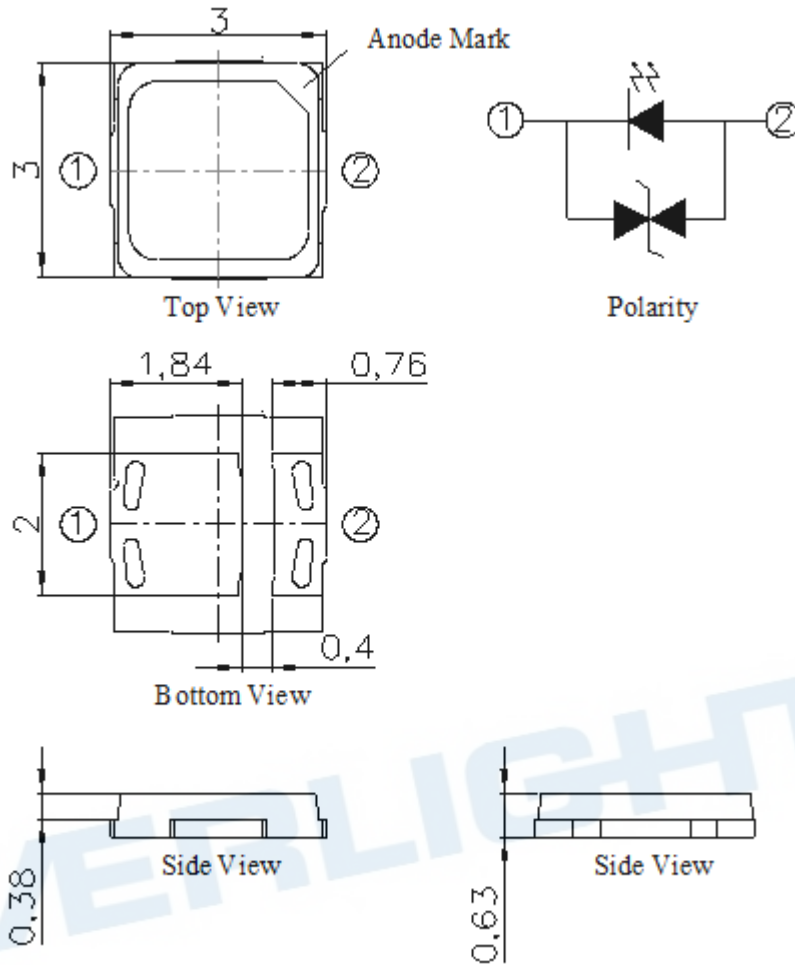

Notes:

1. Dimensions are in millimeters.
2. Tolerances unless mentioned are ± 0.1 mm.

8.Recommended Soldering Pad

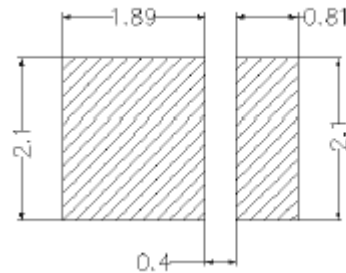

9.Reflow Soldering Profile

Soldering Condition (Reference: IPC/JEDEC J-STD-020D)

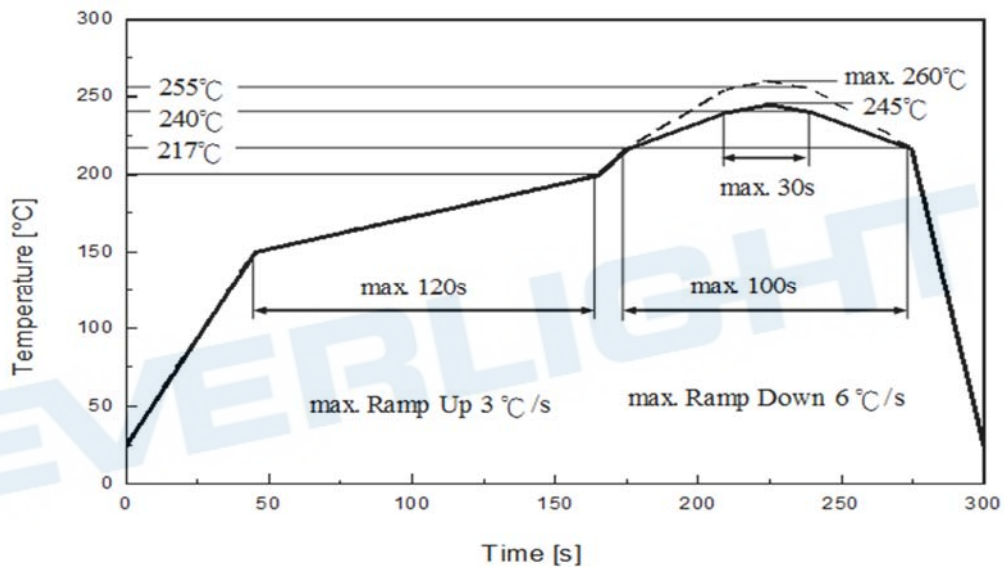

Profile Feature	Pb-Free Assembly	Unit Einheit
	Recommendation	
Ramp-up rate to preheat 25 °C to 150 °C	3	°C /sec
Time of soaking zone 150 °C to 200 °C	120	sec
Ramp-up rate to peak	3	°C /sec
Liquidus temperature	217	°C
Time above liquidus temperature	100	sec
Peak temperature (max.)	260	°C
Time within 5°C of the specified peak temperature	30	sec
Ramp-down Rate (max.)	6	°C /sec

10. Packaging Information

● Product Labeling



- CPN : Customer's Product Number
- P/N : Everlight Part Number
- QTY : Packing Quantity
- CAT : Luminous Flux (Brightness) Bin
- HUE : Color Bin
- REF : Forward Voltage Bin
- LOT No : Lot Number

● Packing: Loaded Quantity 2000 pcs Per Reel

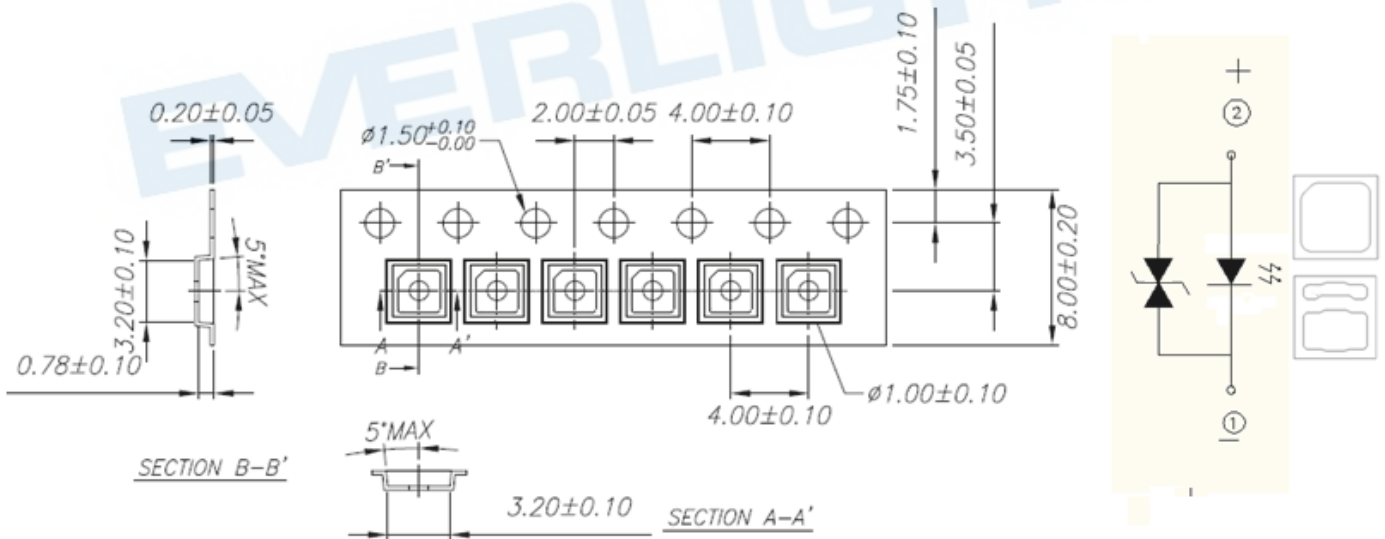

Notes:

1. Dimensions are in millimeters.

Reel Dimensions

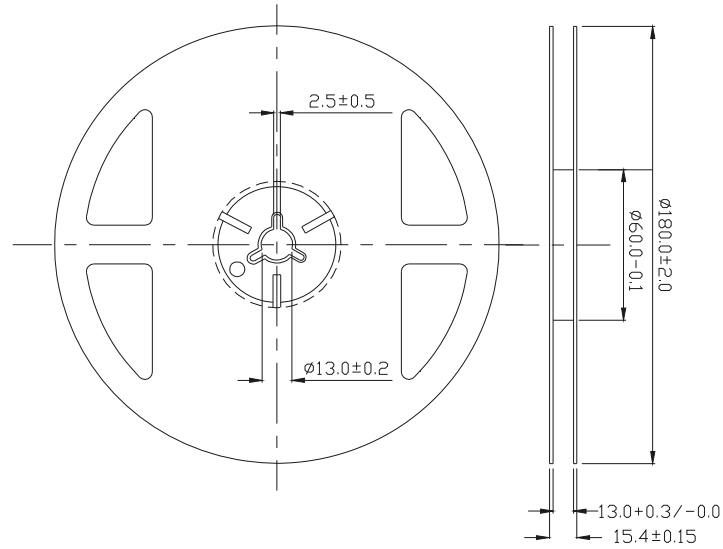

Notes:

1. Dimensions are in millimeters.

- **Moisture Resistant Packing Process**

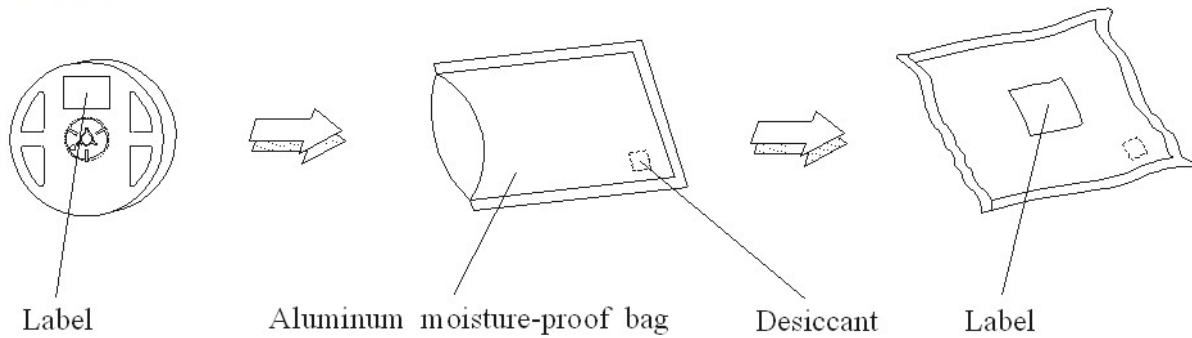

Notes:

1. Dimensions are in millimeters.

11. Precaution for Use

1. Over-current-proof

Customer must apply resistors for protection; otherwise slight voltage shift will cause big current change (burn out will happen).

2. Assemblies

Do not stack assemblies containing LEDs to prevent damage to the optical surface of LEDs. Forces applied to the optical surface may result in the surface being damaged.

3. Soldering Condition

3.1 When soldering, do not put stress on the LEDs during heating.

3.2 After soldering, do not warp the circuit board.

4. Soldering Iron

Each terminal is to go to the tip of soldering iron temperature less than 350°C for 3 seconds within once in less than the soldering iron capacity 25W. Leave two seconds and more intervals, and do soldering of each terminal. Be careful because the damage of the product is often started at the time of the hand solder.

5. Repairing

Repair should not be done after the LEDs have been soldered. When repairing is unavoidable, a double-head soldering iron should be used (as below figure). It should be confirmed beforehand whether the characteristics of the LEDs will or will not be damaged by repairing.

