

EL MULTI COLOR TOP VIEW

3735-C8PA1501H-AM



Features

Package : PLCC 4 package

Typ. Luminous Flux Cool White : 47.0 lm @ 150mA

Typ. Luminous Flux PC Amber : 27.0 lm @ 150mA

Viewing angle : 120°

ESD : 8KV

MSL : 2

Qualifications : According to AEC-Q102

Compliance with RoHS & REACH

Compliance Halogen Free. (Br<900ppm,Cl<900ppm,Br+Cl<1500ppm)

Sulfur robustness

Applications

Automotive Exterior Lighting

Contents

1. Characteristics.....	3
2. Absolute Maximum Ratings.....	4
3. Characteristics Graph.....	5
4. Binning Information	12
5. Part Number.....	17
6. Ordering Information.....	18
7. Mechanical Dimension.....	19
8. Recommended Soldering Pad	19
9. Reflow Soldering Profile.....	20
10. Packaging Information	21
11. Precaution for Use.....	22

1. Characteristics

Parameter		Symbol	Min.	Typ.	Max.	Unit	Condition ^[1]
Forward Current	CW / PA	I_F	5	150	200	mA	---
Luminous Flux ^{[2][3]}	Cool White	Φ_v	39	47	70	lm	$I_F=150\text{mA}$
	PC Amber	Φ_v	20	27	39	lm	$I_F=150\text{mA}$
Forward Voltage ^{[4][5]}	Cool White	V_F	2.75	3.00	3.50	V	$I_F=150\text{mA}$
	PC Amber						
Viewing Angle	Cool White	ϕ	---	120	---	deg	$I_F=150\text{mA}$
	PC Amber						
Chromaticity Coordinates ^[6]	Cool White	CIE_x	---	0.325	---	---	$I_F=150\text{mA}$
		CIE_y	---	0.335	---		
	PC Amber	CIE_x	---	0.570	---		
		CIE_y	---	0.420	---		
Thermal Resistance (Junction to Solder)	CW / PA	$R_{th JS real}$	---	40	---	K/W	$I_F=150\text{mA}$
		$R_{th JS el}$	---	30	---		

Notes:

1. Forward conditon by each of LED.
2. Luminous flux measurement tolerance: $\pm 8\%$.
3. The data of luminous flux measured at thermal pad=25°C
4. Forward voltage measurement tolerance: $\pm 0.05\text{V}$
5. Tolerance of Chromaticity coordinates x,y : ± 0.005

2. Absolute Maximum Ratings

Parameter	Symbol	Ratings	Unit
Power Dissipation	P_d	700	mW
Forward Current	I_F	200	mA
Reverse Voltage	V_R	Not designed for reverse operation	V
Junction Temperature	T_J	150	°C
Operating Temperature	T_{opr}	-40 ~ +125	°C
Storage Temperature	T_{stg}	-40 ~ +125	°C
ESD Sensitivity (R=1.5kΩ, C= 100pF)	ESD_{HBM}	8	KV
Soldering Temperature	Reflow	260°C for 30sec	°C

EVERLIGHT

3. Characteristics Graph

Wavelength Characteristics Relative Spectral Distribution
@ T_S = 25°C 、 I_F = 150mA (CW)

$$\Phi_v / \Phi_v (Max.) = f(\lambda)$$

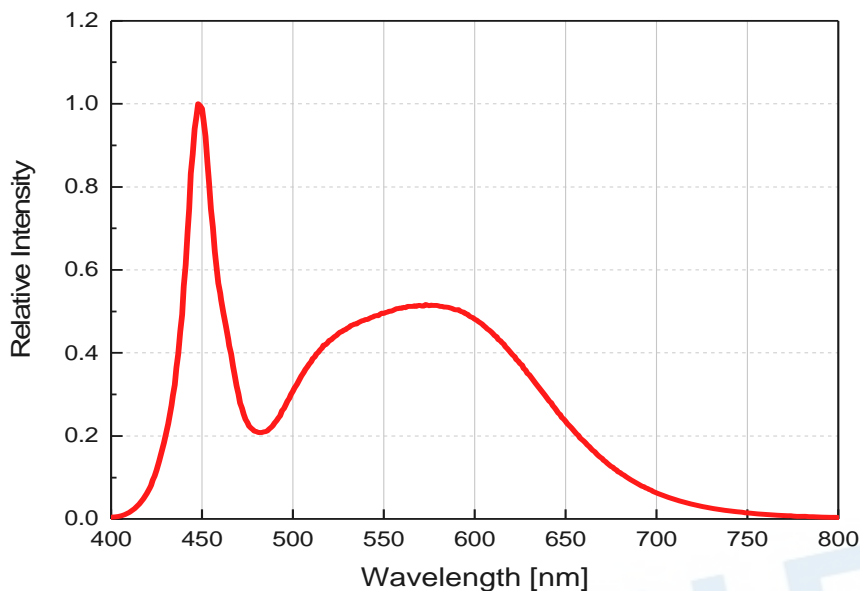

Wavelength Characteristics Relative Spectral Distribution
@ T_S = 25°C 、 I_F = 150mA (PC Amber)

$$\Phi_v / \Phi_v (Max.) = f(\lambda)$$

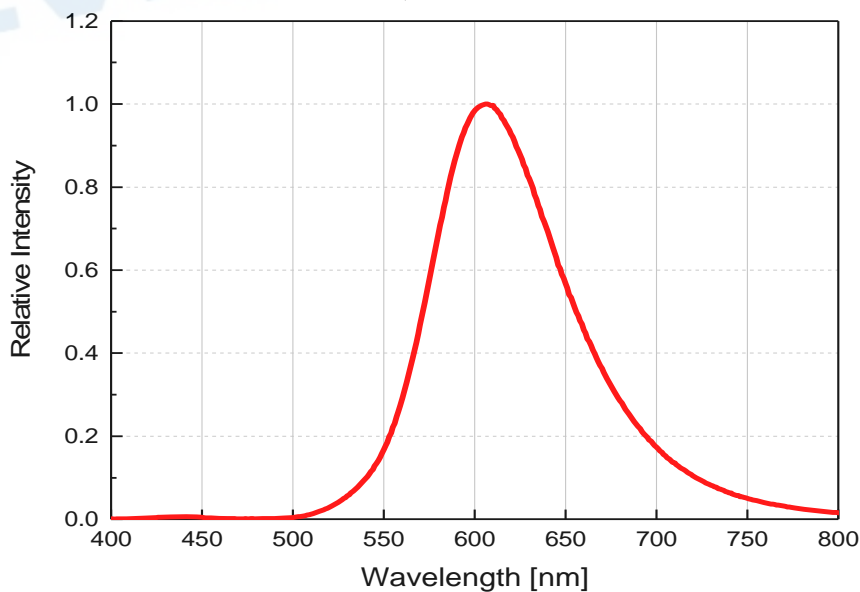

Typical Diagram Characteristics of Radiation (CW / PA)

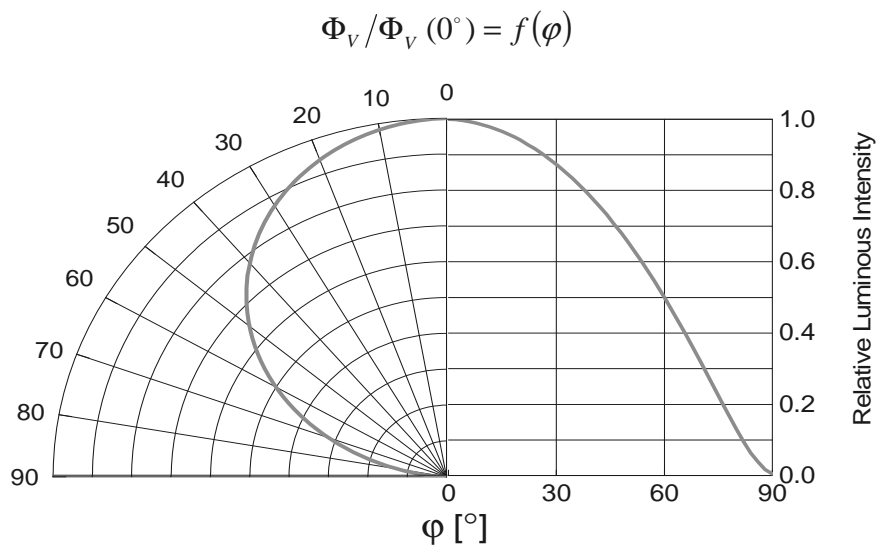

Notes:

1. φ is the off axis angle from lamp centerline where the luminous intensity is 1/2 of the peak value.
2. View angle tolerance is $\pm 5^\circ$

Forward Current vs. Forward Voltage @ $T_s = 25^\circ\text{C}$ (CW / PC amber)

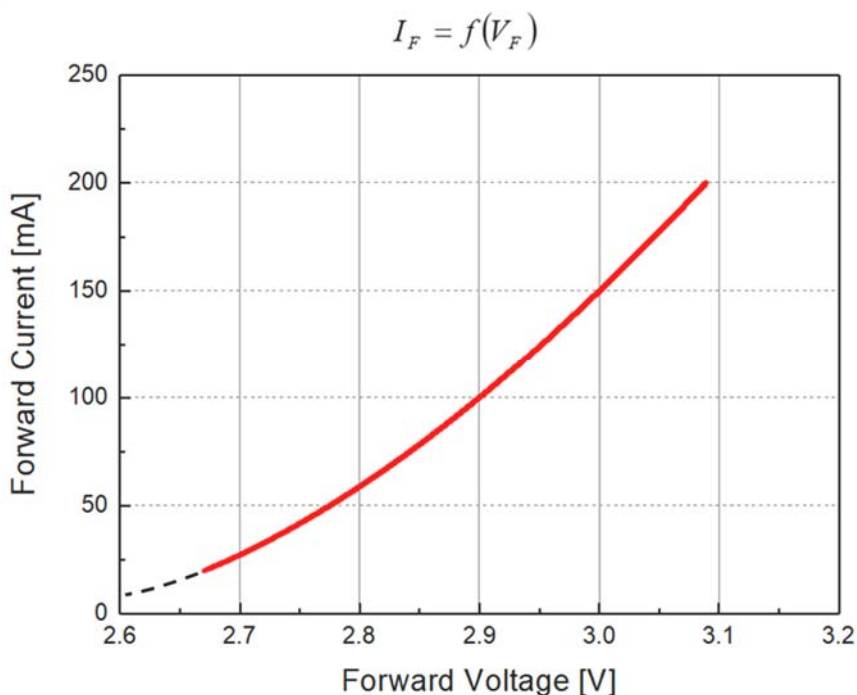

**Relative Luminous Flux vs. Forward Current
@ T_s = 25°C (CW / PA)**

$$\Phi_V / \Phi_V(150mA) = f(I_F)$$

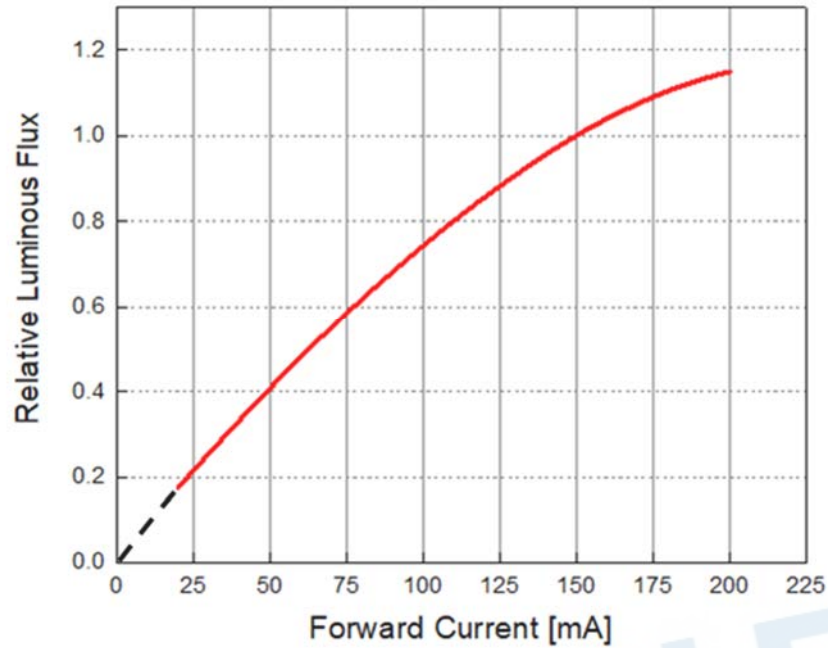

**Chromaticity Coordinates vs. Forward Current
@ T_s = 25°C (CW)**

$$\Delta CIE x, \Delta CIE y = f(I_F)$$

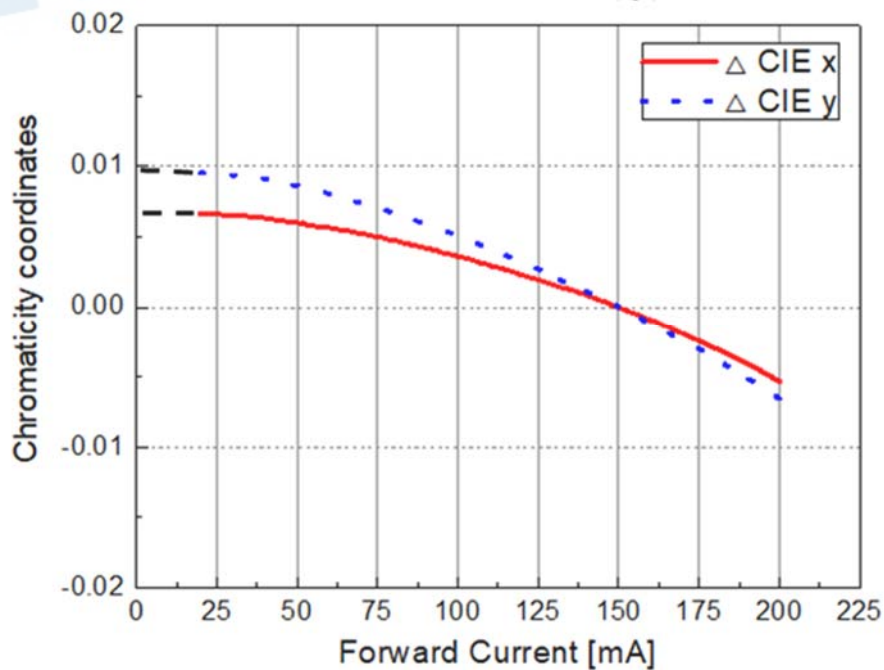

Chromaticity Coordinates vs. Forward Current
@ T_s = 25°C (PC Amber)

$$\Delta CIE\ x, \Delta CIE\ y = f(I_F)$$

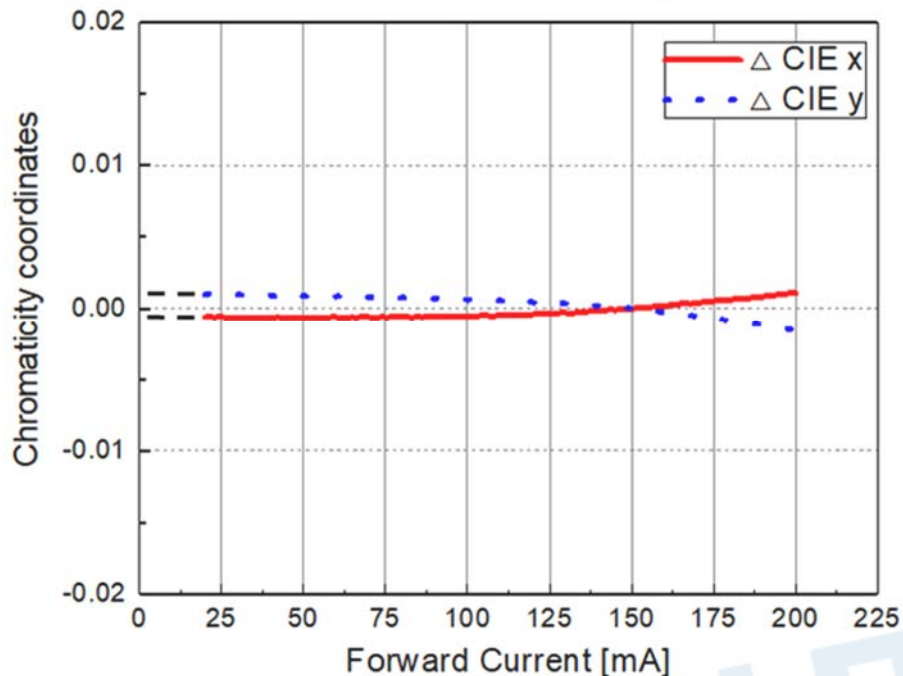

Relative Forward Voltage vs. Junction Temperature
@ I_F = 150mA (CW / PA)

$$\Delta V_F = V_F - V_F(25^\circ C) = f(T_j)$$

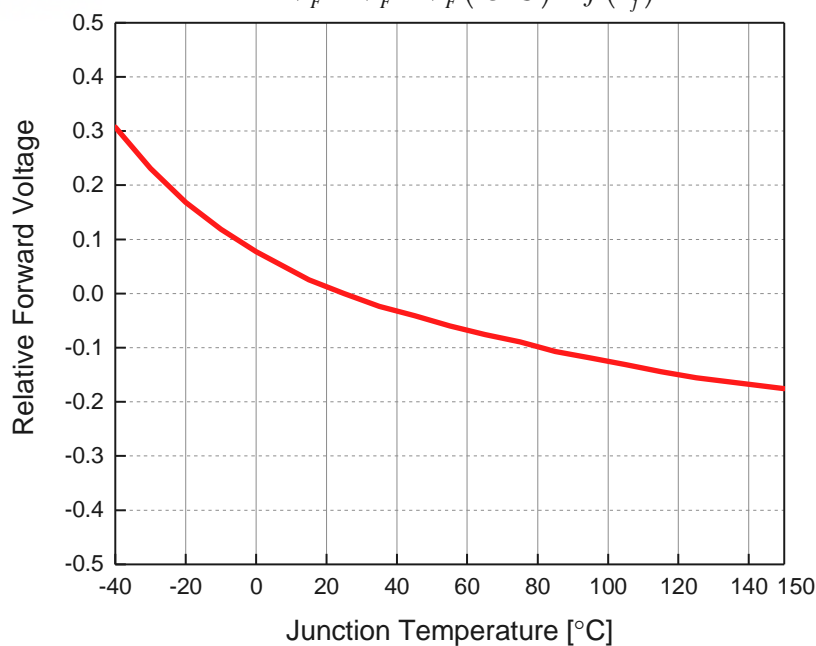

**Relative Luminous Flux vs. Junction Temperature
@ I_F = 150mA (CW)**

$$\Phi_V / \Phi_V(25^\circ C) = f(T_j)$$

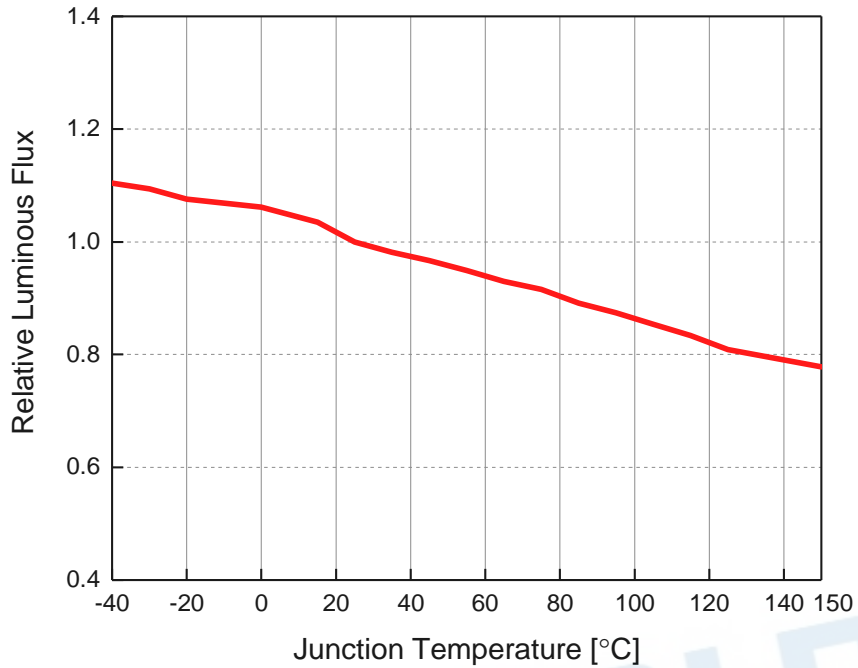

**Relative Luminous Flux vs. Junction Temperature
@ I_F = 150mA (PC Amber)**

$$\Phi_V / \Phi_V(25^\circ C) = f(T_j)$$

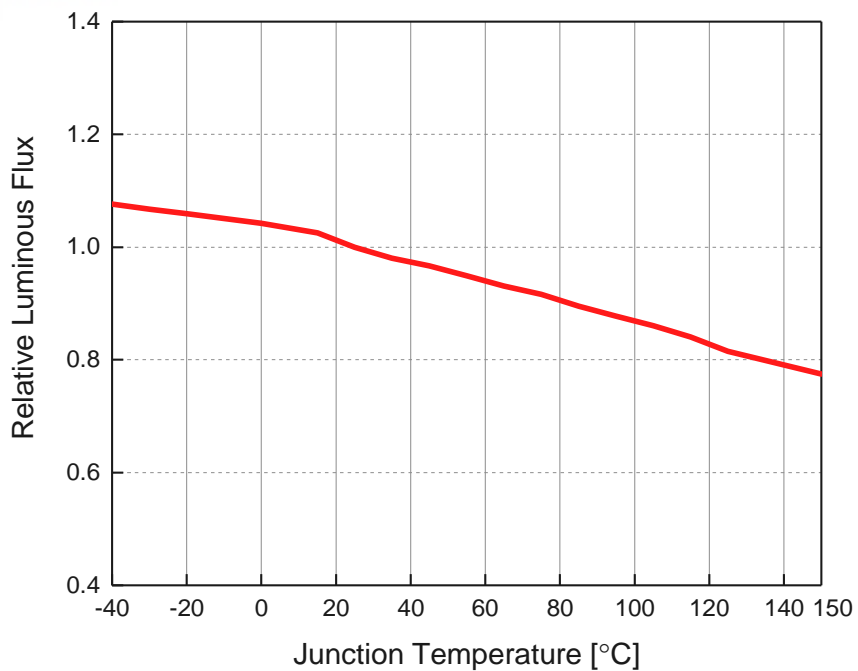

**Chromaticity Coordinates Shift vs. Junction Temperature
@ I_F = 150mA (CW)**

$$\Delta CIE_x, \Delta CIE_y = f(T_j)$$

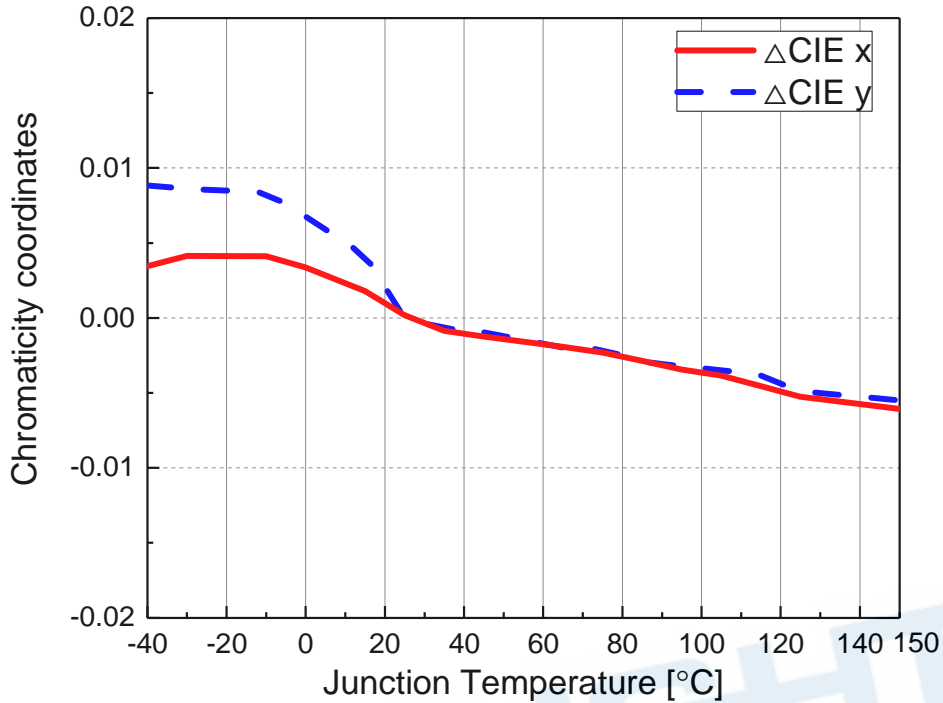

**Chromaticity Coordinates Shift vs. Junction Temperature
@ I_F = 150mA (PC Amber)**

$$\Delta CIE_x, \Delta CIE_y = f(T_j)$$

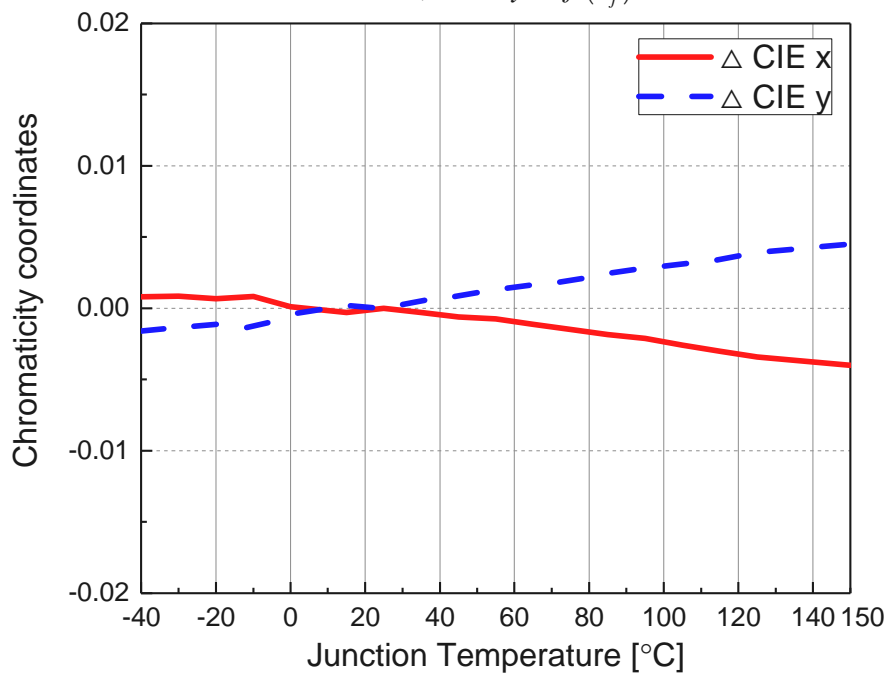

**Forward Current Derating Curve
(CW / PA)**

$$I_F = f(T_S)$$

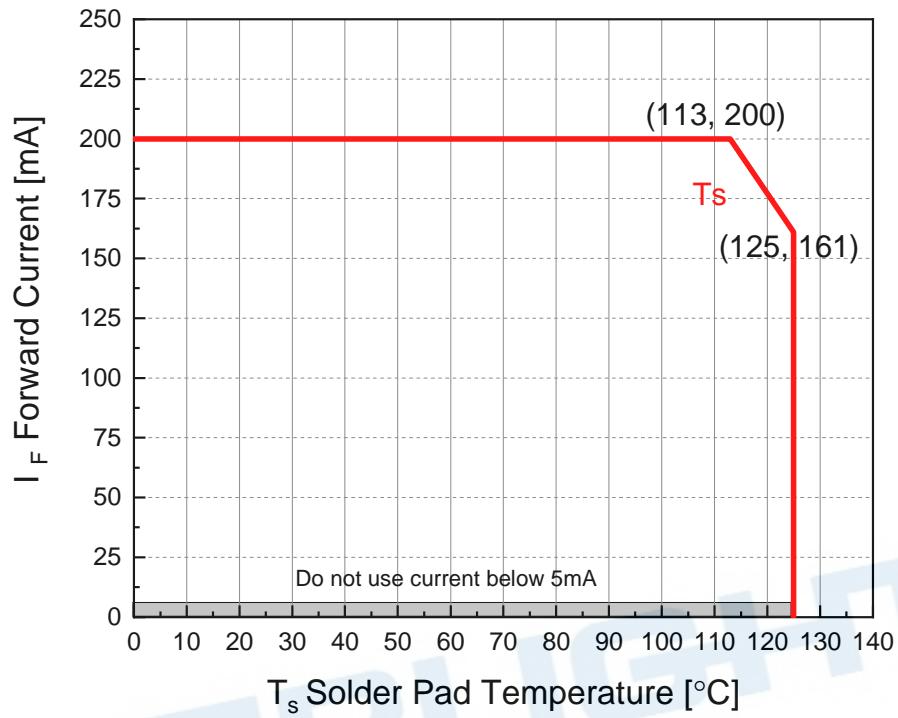

4. Binning Information

Luminous Flux Bins

[Cool White]			
Group	Bin	Minimum Photometric Flux (lm)	Maximum Photometric Flux (lm)
F	2	33	39
	3	39	45
	4	45	52
	5	52	60
	6	60	70
	7	70	80
	8	80	90
9	90	100	
J	1	100	110

[PC Amber]			
Group	Bin	Minimum Photometric Flux (lm)	Maximum Photometric Flux (lm)
E	8	20	23
	9	23	27
F	1	27	33
	2	33	39
	3	39	45
	4	45	52
	5	52	60
	6	60	70
	7	70	80

Notes:

1. Luminous flux measurement tolerance: $\pm 8\%$.
2. Highlighted Black Box is available bins.

Forward Voltage Bins

Bin	Minimum Forward Voltage [V]	Maximum Forward Voltage [V]
1012	1.00	1.25
1215	1.25	1.75
1517	1.50	1.75
1720	1.75	2.00
2022	2.00	2.25
2225	2.25	2.50
2527	2.50	2.75
2730	2.75	3.00
3032	3.00	3.25
3235	3.25	3.50
3537	3.50	3.75
3740	3.75	4.00
4042	4.00	4.25
4245	4.25	4.50
4547	4.50	4.75
4750	4.75	5.00
5052	5.00	5.25
5255	5.25	5.50
5557	5.50	5.75
5760	5.75	6.00
6062	6.00	6.25
6265	6.25	6.50
6567	6.50	6.75
6770	6.75	7.00

Notes:

1. Forward voltage measurement tolerance: $\pm 0.05V$.
2. Forward voltage bins are defined at $I_F = 150mA$ operation.

Color Bin Structure ECE Bin Structure

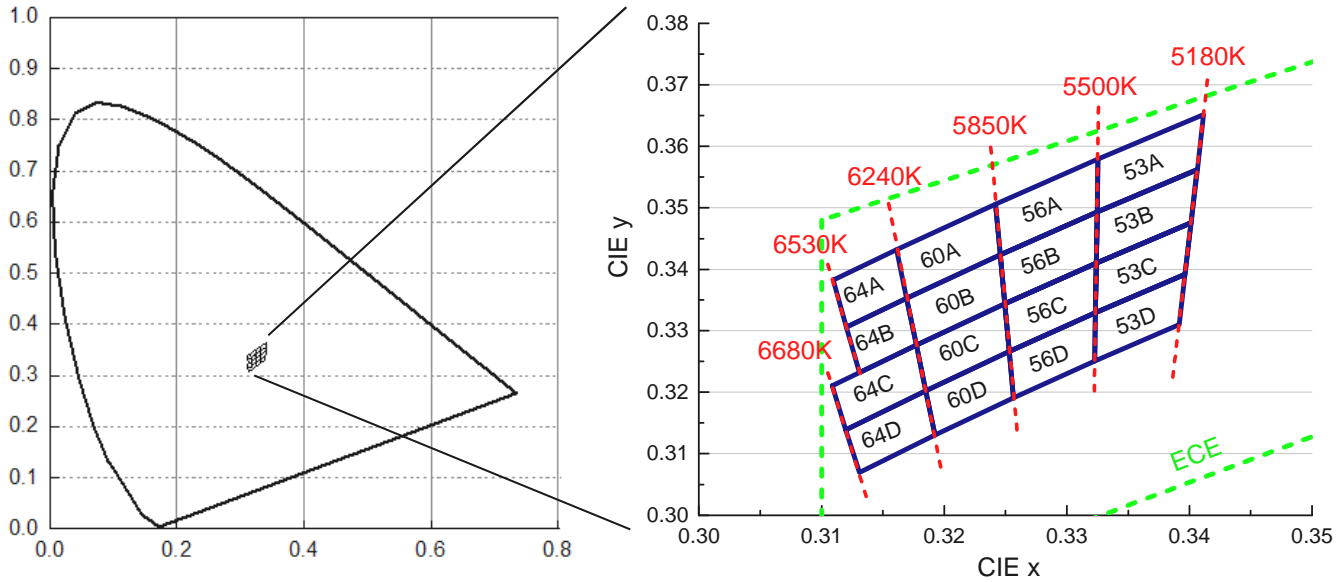

Cool White Bin Coordinates

Bin	CIE x	CIE y
64A	0.3109	0.3382
	0.3161	0.3432
	0.3169	0.3353
	0.3120	0.3306
Reference Range: 6240~6530K		

Bin	CIE x	CIE y
64B	0.3120	0.3306
	0.3169	0.3353
	0.3177	0.3277
	0.3131	0.3232
Reference Range: 6240~6530K		

Bin	CIE x	CIE y
64C	0.3109	0.3211
	0.3177	0.3277
	0.3185	0.3203
	0.3120	0.3139
Reference Range: 6240~6680K		

Bin	CIE x	CIE y
64D	0.3120	0.3139
	0.3185	0.3203
	0.3192	0.3131
	0.3131	0.3070
Reference Range: 6240~6680K		

Bin	CIE x	CIE y
60A	0.3161	0.3432
	0.3242	0.3506
	0.3246	0.3424
	0.3169	0.3353
Reference Range: 5850~6240K		

Bin	CIE x	CIE y
60B	0.3169	0.3353
	0.3246	0.3424
	0.3249	0.3344
	0.3177	0.3277
Reference Range: 5850~6240K		

Bin	CIE x	CIE y
60C	0.3177	0.3277
	0.3249	0.3344
	0.3253	0.3266
	0.3185	0.3203
Reference Range: 5850~6240K		

Bin	CIE x	CIE y
60D	0.3185	0.3203
	0.3253	0.3266
	0.3256	0.3191
	0.3192	0.3131
Reference Range: 5850~6240K		

Bin	CIE x	CIE y
56A	0.3242	0.3506
	0.3325	0.3579
	0.3325	0.3493
	0.3246	0.3424
Reference Range: 5500~5850K		

Bin	CIE x	CIE y
56B	0.3246	0.3424
	0.3325	0.3493
	0.3324	0.3410
	0.3249	0.3344
Reference Range: 5500~5850K		

Bin	CIE x	CIE y
56C	0.3249	0.3344
	0.3324	0.3410
	0.3323	0.3329
	0.3253	0.3266
Reference Range: 5500~5850K		

Bin	CIE x	CIE y
56D	0.3253	0.3266
	0.3323	0.3329
	0.3323	0.3251
	0.3256	0.3191
Reference Range: 5500~5850K		

Bin	CIE x	CIE y
53A	0.3325	0.3579
	0.3412	0.3652
	0.3406	0.3562
	0.3325	0.3493
Reference Range: 5180~5500K		

Bin	CIE x	CIE y
53B	0.3325	0.3493
	0.3406	0.3562
	0.3401	0.3476
	0.3324	0.3410
Reference Range: 5180~5500K		

Bin	CIE x	CIE y
53C	0.3324	0.3410
	0.3401	0.3476
	0.3396	0.3392
	0.3323	0.3329
Reference Range: 5180~5500K		

Bin	CIE x	CIE y
53D	0.3323	0.3329
	0.3396	0.3392
	0.3392	0.3310
	0.3323	0.3251
Reference Range: 5180~5500K		

Notes:

1. Color coordinates measurement tolerance: ± 0.005 .

Color Bin Structure ECE Bin Structure

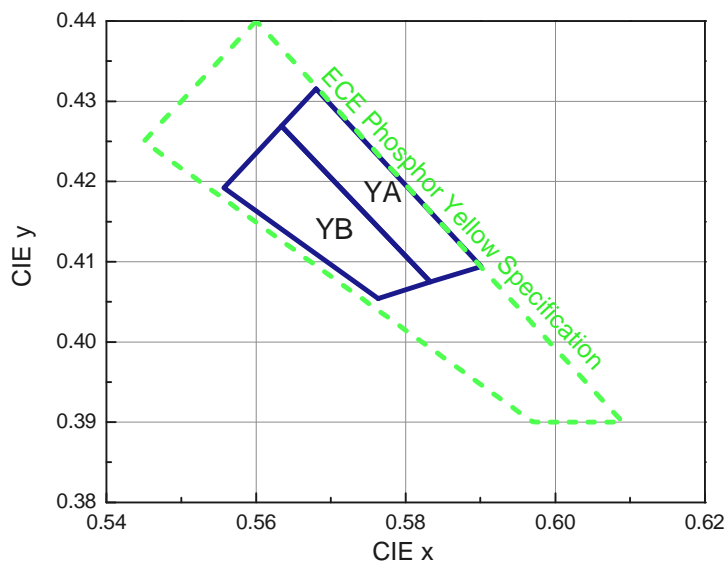
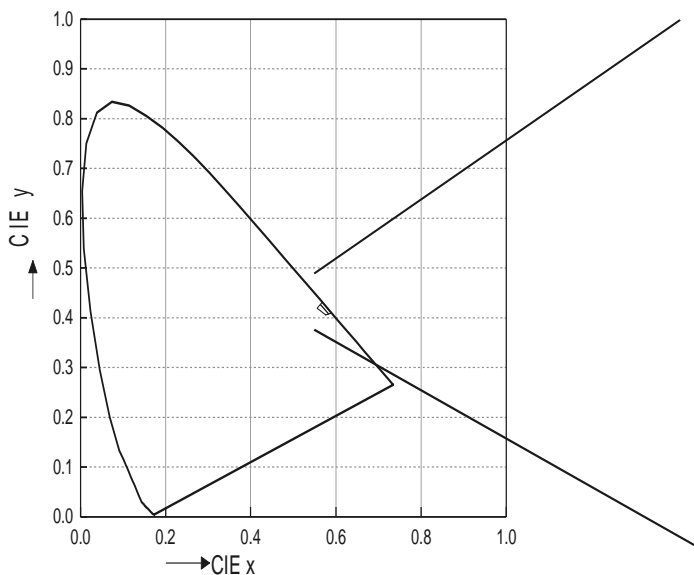

PC Amber Bin Coordinates

Bin	CIE x	CIE y
YA	0.5680	0.4315
	0.5634	0.4269
	0.5833	0.4075
	0.5901	0.4094

Bin	CIE x	CIE y
YB	0.5763	0.4054
	0.5833	0.4075
	0.5634	0.4269
	0.5557	0.4192

Notes:

1. Color coordinates measurement tolerance: ± 0.005 .

5. Part Number

3735-C8PA1501H-AM

Part number is designated with below details.

3735 = Product family name.

C = Color ^[1]

8 = CRI (0=N/A ; >70=7 ; >80=8 ; >90=9)

PA= Color ^[1]

150 = Test current [mA]

1 = Lead frame type (0=Ag ; 1=Au ; 2=MLP)

H = Brightness level (H=High ; M=Medium ; L=Low)

AM = Automotive application

Note : ^[1] Color :

Symbol	Description
C	Cool White
N	Neutral White
W	Warm White
PA	Phosphor Converted Amber
PR	Phosphor Converted Red
UB	Blue
IB	Ice Blue
SB	Sky Blue
UP	Purple
UG	Green
UY	Yellow
UA	Amber
UR	Red
SR	Super Red
RGB	RGB-Color
PYG	Phosphor Converted Yellow Green

6. Ordering Information

3735-C8PA1501H-**ABCDEF**-1T-AM

Part Number of the 3735	Order Code
3735-C8PA1501H-AM	3735-C8PA1501H- ABCDEF -1T-AM

Order code contains information with below details :

ABCDEF = Group Bin^[1]

1T = Internal Code

Note:

[1] Group Bin Chart :

Group Bin	Bin Coordinates	IV	VF
010101	CW: 56B64D PA: YAYB	CW: F3F6 PA: E8F2	2735

7. Mechanical Dimension

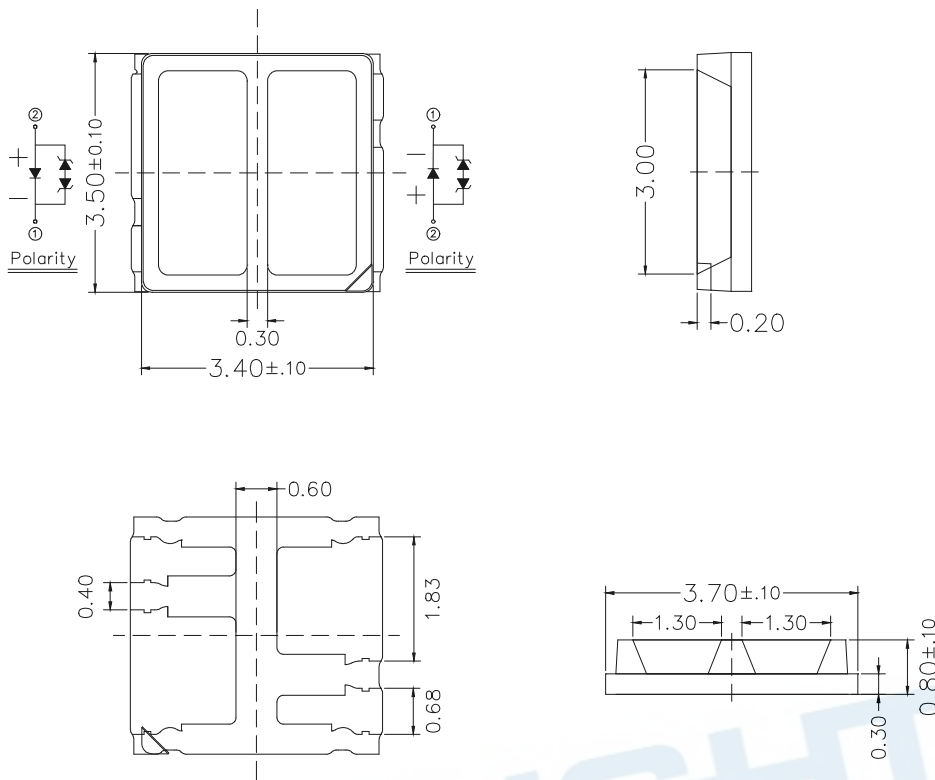

Notes:

1. Dimensions are in millimeters.
2. Tolerances unless mentioned are ± 0.1 mm.

8. Recommended Soldering Pad

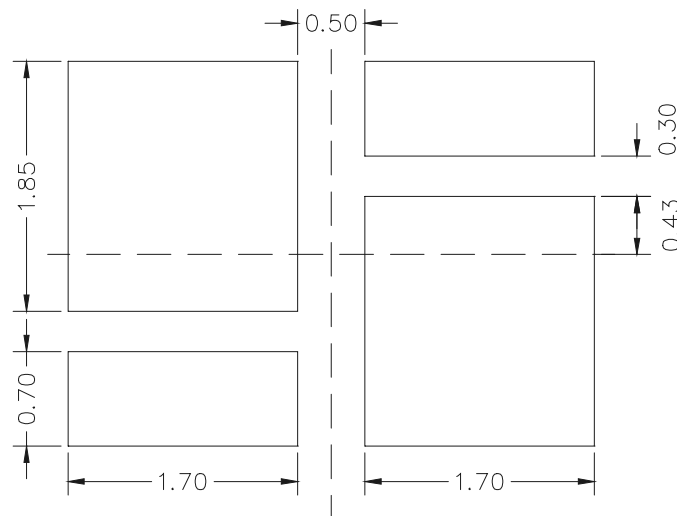

9. Reflow Soldering Profile

Soldering Condition (Reference: IPC/JEDEC J-STD-020D)

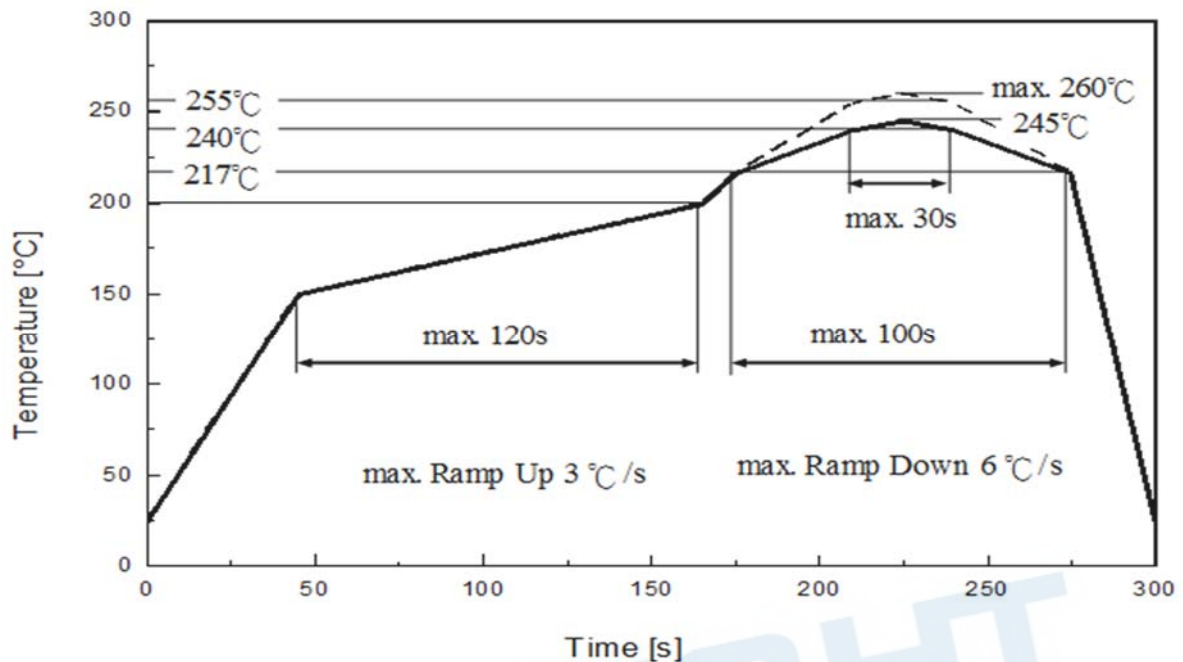

Profile Feature	Pb-Free Assembly	Unit Einheit
Ramp-up rate to preheat 25 °C to 150 °C	3	°C /sec
Time of soaking zone 150 °C to 200 °C	120	sec
Ramp-up rate to peak	3	°C /sec
Liquidus temperature	217	°C
Time above liquidus temperature	100	sec
Peak temperature (max.)	260	°C
Time within 5°C of the specified peak temperature	30	sec
Ramp-down Rate (max.)	6	°C /sec

10. Packaging Information

● Product Labeling

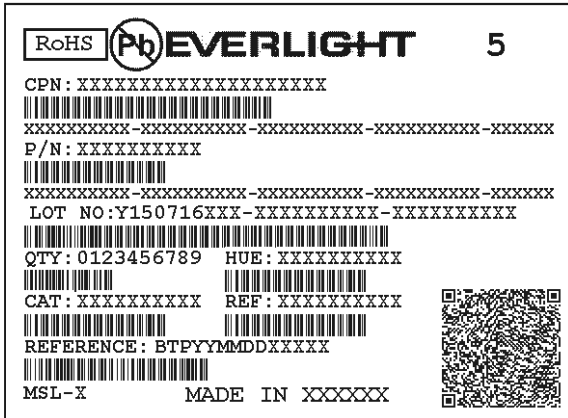

- CPN : Customer's Product Number
- P/N : Everlight Part Number
- LOT NO : Lot Number
- QTY : Packing Quantity
- HUE : Color Bin
- CAT : Luminous Flux (Brightness) Bin
- REF : Forward Voltage Bin

● Packing: Loaded Quantity 500 pcs Per Reel

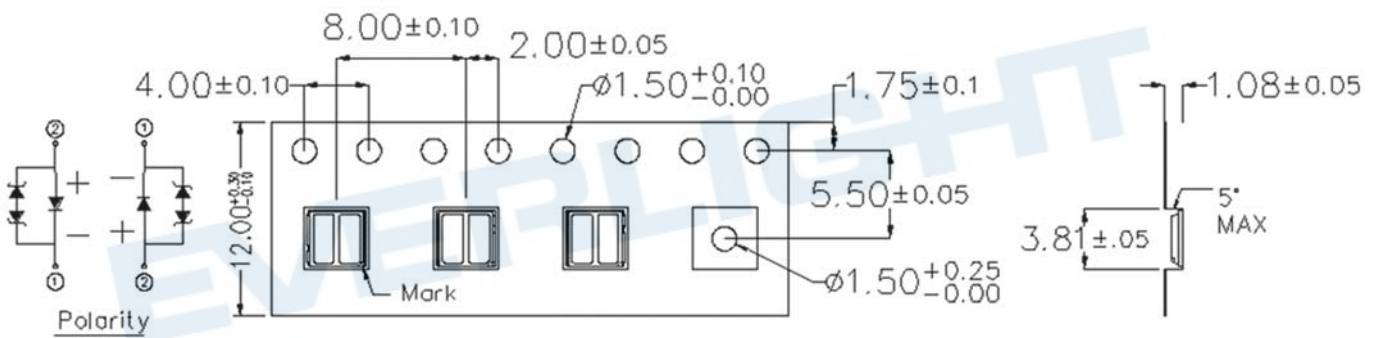

● Reel Dimensions

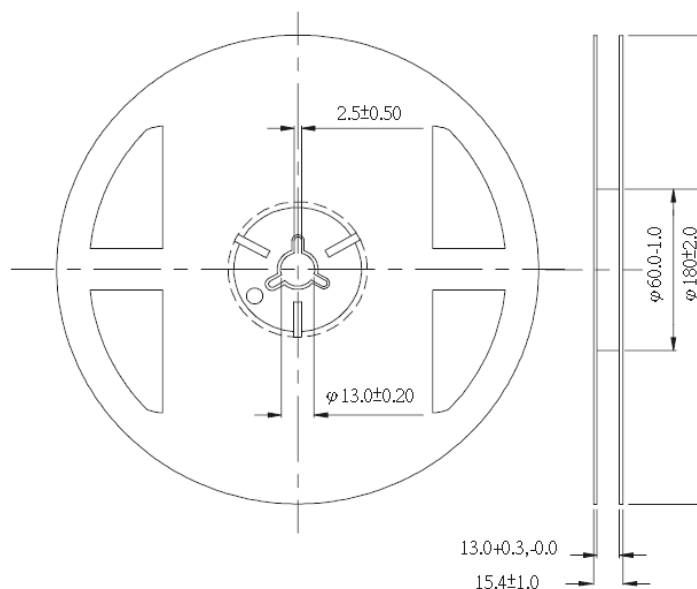

Notes: Dimensions are in millimeters.

Moisture Resistant Packing Process

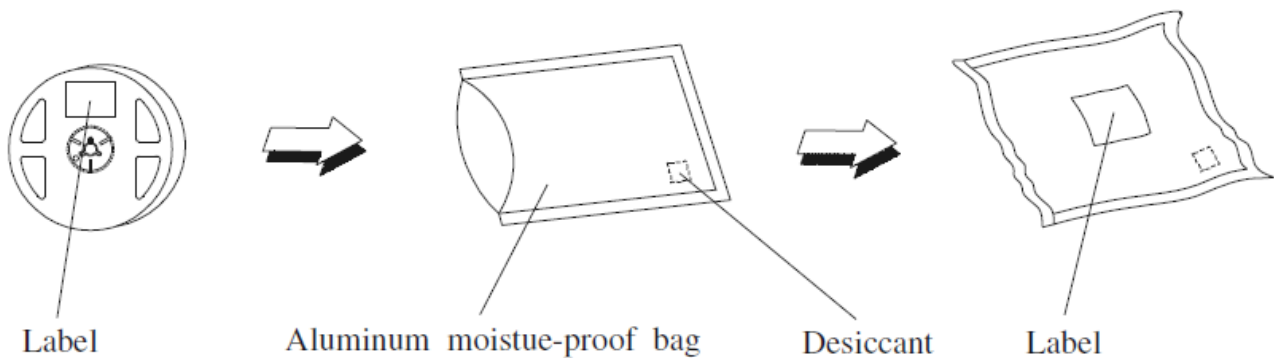

11. Precaution for Use

- Over-current-proof**
Customer must apply resistors for protection; otherwise slight voltage shift will cause big current change (burn out will happen).
- Assemblies**
Do not stack assemblies containing LEDs to prevent damage to the optical surface of LEDs. Forces applied to the optical surface may result in the surface being damaged.
- Soldering Condition**
 - When soldering, do not put stress on the LEDs during heating.
 - After soldering, do not warp the circuit board.
- Soldering Iron**
Each terminal is to go to the tip of soldering iron temperature less than 350°C for 3 seconds within once in less than the soldering iron capacity 25W. Leave two seconds and more intervals, and do soldering of each terminal. Be careful because the damage of the product is often started at the time of the hand solder.
- Repairing**
Repair should not be done after the LEDs have been soldered. When repairing is unavoidable, a double-head soldering iron should be used (as below figure). It should be confirmed beforehand whether the characteristics of the LEDs will or will not be damaged by repairing.