

High Power Infrared LED EAIST3535A6

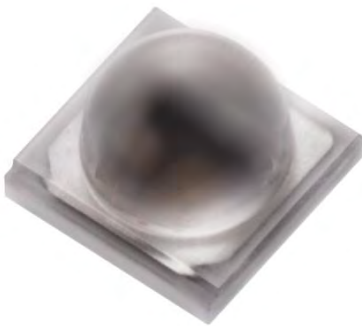

Features

- Small package with high efficiency.
- Peak wavelength $\lambda_p = 850$ nm.
- Soldering methods: SMT.
- Thermal resistance (junction to lead): 23 K/W.
- Pb free.
- Compliance with EU REACH.
- Compliance Halogen Free (Br < 900ppm, Cl < 900ppm, Br+Cl < 1500ppm).
- The product itself will remain within RoHS compliant version.

Description

- The EAIST3535A6 series is an infrared emitting diode in miniature SMD package which is molded in a water clear silicone with spherical top view lens.
- The device is spectrally matched with silicon photo diode, Phototransistor.

Applications

- Network Camera
- Infrared applied system

Device Selection Guide

LED Part No.	Chip Material	Lens Color
EAIST3535A6	GaAlAs	Water clear

Absolute Maximum Ratings (Ta=25 °C)

Parameter	Symbol	Rating	Unit
Forward Current	I_F	1000	mA
Reverse Voltage	V_R	5	V
Operating Temperature	T_{opr}	-40 ~ +100	°C
Storage Temperature	T_{stg}	-40 ~ +100	°C
Junction temperature	T_j	125	°C
Thermal resistance (junction to lead frame)	$R_{th(j-L)}$	23	K/W
Power Dissipation @ $I_F=700mA$	P_d	1	W

Notes: We suggest that customer should add the heat sink with EAIST3535A6 to exclude the heat.

Electro-Optical Characteristics (Ta=25°C)

Parameter	Symbol	Min.	Typ.	Max.	Unit	Condition
Total Radiated Power	Po	--	270	--	mW	I _F =350 mA
		--	520	--		I _F =700 mA
		--	680	--		I _F =1000 mA
Radiant Intensity	I _E	--	110	--	mW/sr	I _F =350 mA
		--	220	--		I _F =700 mA
		--	300	--		I _F =1000 mA
Peak Wavelength	λ _p	--	850	--	nm	I _F =350 mA
Spectral Bandwidth	Δλ	--	25	--	nm	I _F =350 mA
Forward Voltage	V _F	--	1.70	--	V	I _F =350 mA
		--	2.10	--		I _F =700 mA
		--	2.30	--		I _F =1000 mA
Reverse Current	I _R	--	--	10	μA	V _R =5 V
View Angle	2θ _{1/2}	--	90	--	deg	I _F =20 mA

Bin Code List

Radiated Power

Condition: I_F=1000mA

Unit : mW

Bin Number	E	F
Min	500	640
Max	800	1000

Including test tolerance ±10%

Fig.1
 Forward Current vs. Forward Voltage

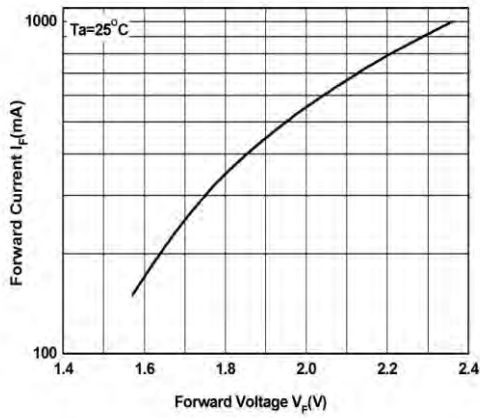

Fig.2
 Forward Current vs. Intensity

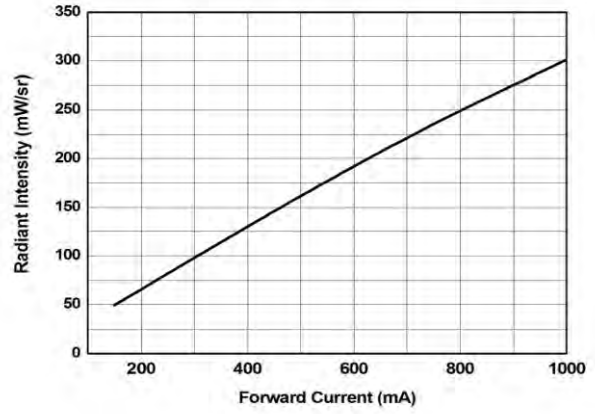

Fig.3
 Forward Current vs. Total Radiated Power

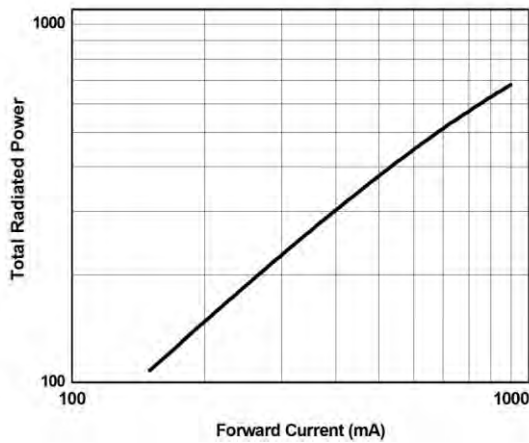

Fig.4
 Relative Radiant Intensity vs. Angular Displacement

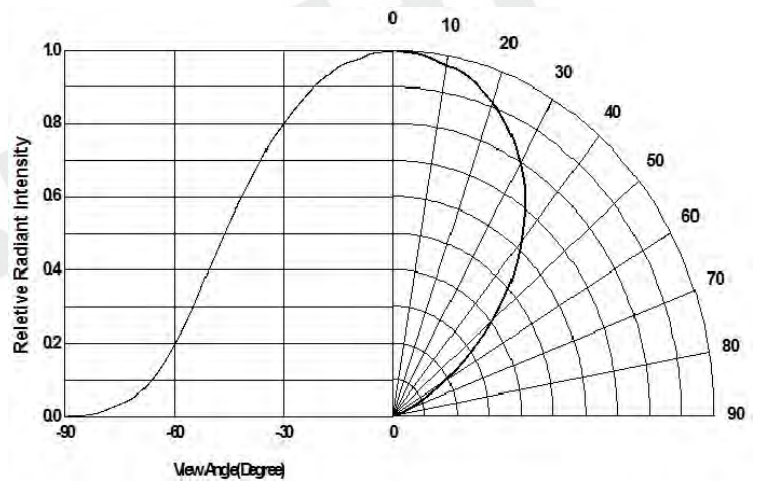
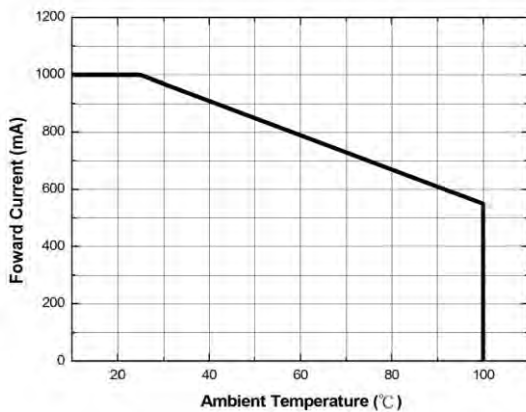
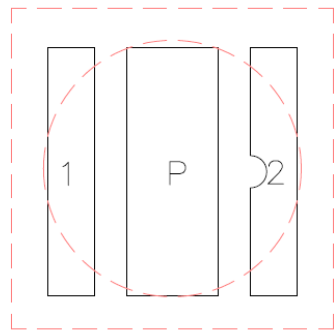

Fig.5
 Forward Current vs. Ambient Temperature



Pad Configuration

Pad	1	2	P
Function	Anode	Cathode	Thermal Pad



Bottom View

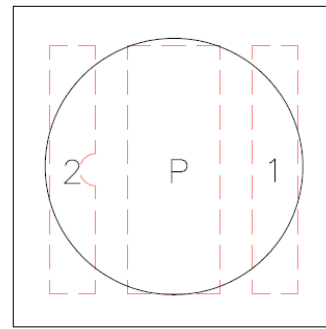

Top View

Reflow Soldering Characteristics

For Reflow Process

1. C19 series are suitable for SMT processes.
2. Curing of glue in oven must be according to standard operation flow processes.

Profile Feature	Lead Free Assembly	Unit
Ramp-Up Rate	2~3	°C/S
Preheat Temperature	150~200	°C
Preheat Time(t_s)	60~120	S
Liquid Temperature(T_L)	217	°C
Time maintained above T_L	60~90	S
Peak Temperature(T_p)	240+-5	°C
Peak Time (t_p)	Max 20	S
Ramp-Down Rate	3~5	°C/S

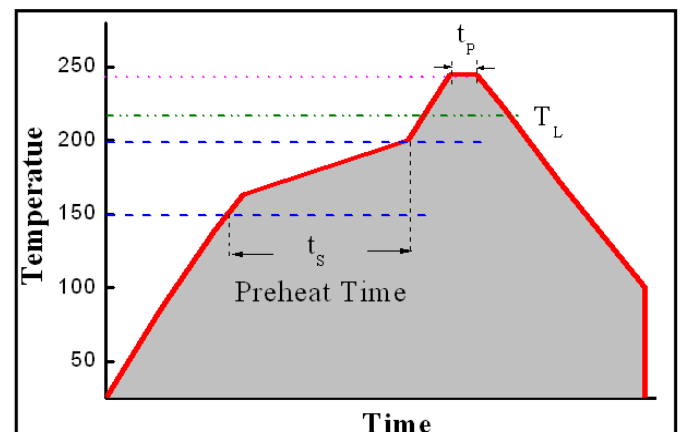

3. Reflow soldering should not be done more than twice.
4. In soldering process, stress on the LEDs during heating should be avoided.
5. After soldering, do not bend the circuit board.

Package Dimension

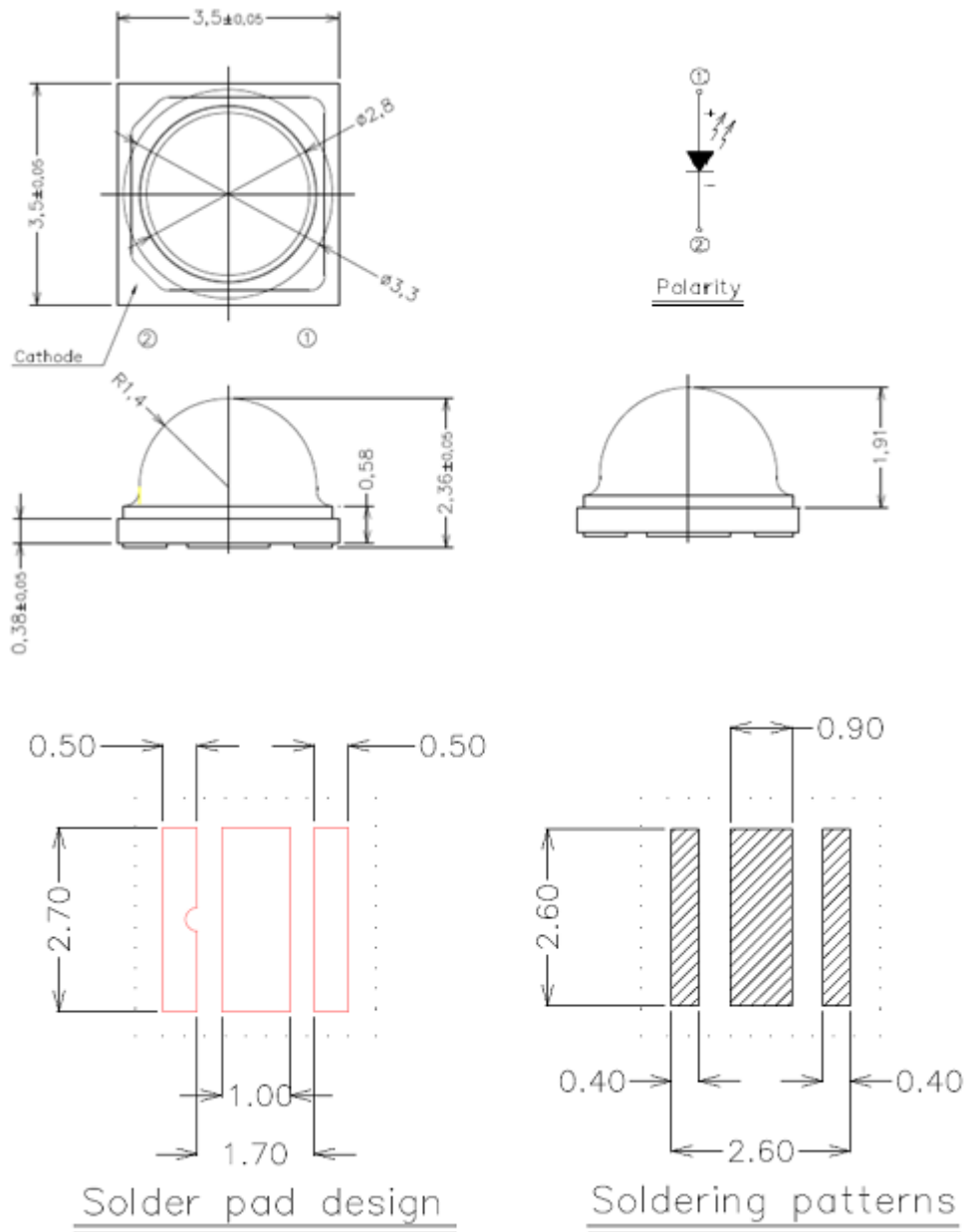

1. Dimensions are in millimeters.
2. Tolerances unless mentioned are ± 0.1 mm.
3. Do not handle the device by the lens. Incorrect force applied to the lens may lead to the failure of devices.

Package Dimensions

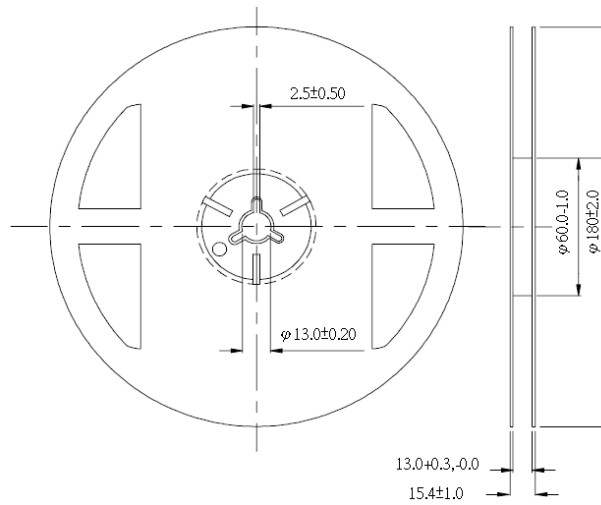

Note:

1. Dimensions are in millimeters
2. The tolerances unless mentioned is ± 0.1 mm

Carrier Tape Dimensions:

Loaded quantity 400 pcs per reel.

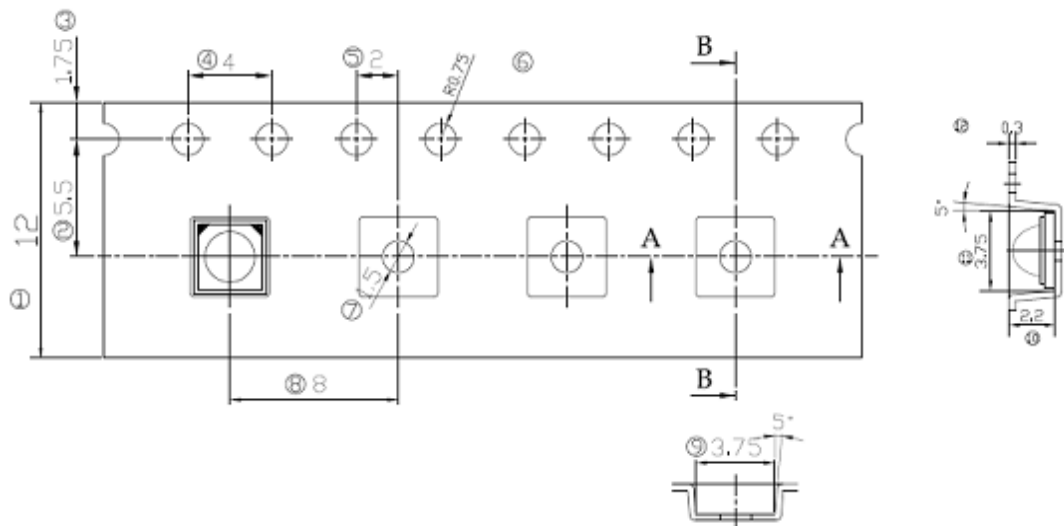

Note:

1. Dimensions are in millimeters
2. The tolerances unless mentioned is ± 0.1 mm

Mois

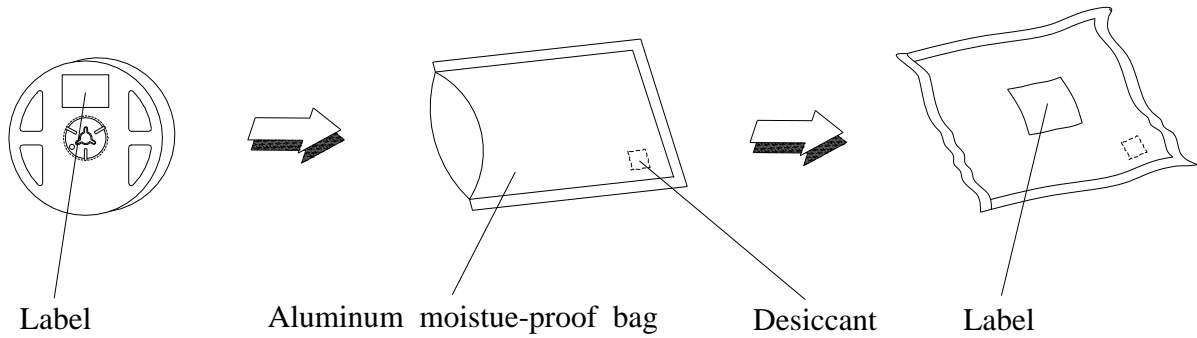

Moisture Resistant Packing Materials

Label Form Specification



- CPN: Customer's Product Number
- P/N: Product Number
- QTY: Packing Quantity
- CAT: Luminous Intensity Rank
- HUE: Dom. Wavelength Rank
- REF: Forward Voltage Rank
- LOT No: Lot Number
- X: Month
- Reference: Identify Label Number

DISCLAIMER

1. EVERLIGHT reserves the right(s) on the adjustment of product material mix for the specification.
2. The product meets EVERLIGHT published specification for a period of twelve (12) months from date of shipment.
3. The graphs shown in this datasheet are representing typical data only and do not show guaranteed values.
4. When using this product, please observe the absolute maximum ratings and the instructions for using outlined in these specification sheets. EVERLIGHT assumes no responsibility for any damage resulting from the use of the product which does not comply with the absolute maximum ratings and the instructions included in these specification sheets.
5. These specification sheets include materials protected under copyright of EVERLIGHT. Reproduction in any form is prohibited without obtaining EVERLIGHT's prior consent.
6. This product is not intended to be used for military, aircraft, automotive, medical, life sustaining or life saving applications or any other application which can result in human injury or death. Please contact authorized Everlight sales agent for special application request.