

Top View ■ LED EAPL2214WA1



Features

- White SMT package.
- Optical indicator.
- Wide viewing angle.
- Soldering methods: IR reflow soldering.
- Available on tape and reel.
- Pb-free
- The product itself will remain within RoHS compliant version.

Descriptions

The EAPL2214WA1 series is available in soft orange, green, blue, and yellow. Due to the package design, the LED has wide viewing angle and optimized light coupling by inter reflector. This feature makes the LED ideal for light pipe application.

Applications

- Optical indicators.
- Coupling into light guides.
- Backlighting (LCD, cellular phones, switches, keys, displays, illuminated advertising, general lighting).
- Coupling into light guides.

Device Selection Guide

| Chip | Emitted Color | Resin Color |
|----------|---------------|-------------|
| Material | | |
| InGaN | Pure White | Water Clear |

Bin Range Of Luminous Intensity

| Bin Code | Min. | Max. | Unit | Condition |
|----------|------|------|------|----------------------|
| V2-1 | 1000 | 1120 | mcd | I _F =20mA |
| W1 | 1120 | 1420 | | |
| W2 | 1420 | 1800 | | |

Bin Range Of Forward Voltage

| Group | Bin Code | Min. | Max. | Unit | Condition |
|-------|----------|------|------|------|----------------------|
| B14 | 34 | 2.70 | 2.80 | V | I _F =20mA |
| | 35 | 2.80 | 2.90 | | |
| | 36 | 2.90 | 3.00 | | |
| | 37 | 3.00 | 3.10 | | |
| | 38 | 3.10 | 3.20 | | |
| | 39 | 3.20 | 3.30 | | |
| | 40 | 3.30 | 3.40 | | |
| | 41 | 3.40 | 3.50 | | |

Notes:

1. Tolerance of Luminous Intensity $\pm 11\%$
2. Tolerance of Forward Voltage $\pm 0.05V$

Absolute Maximum Ratings (Ta=25°C)

| Parameter | Symbol | Rating | Unit |
|---|-----------------|---|------|
| Reverse Voltage | V _R | 5 | V |
| Forward Current | I _F | 30 | mA |
| Peak Forward Current (Duty 1/10 @1KHz) | I _{FP} | 100 | mA |
| Power Dissipation | P _d | 110 | mW |
| Electrostatic Discharge(HBM) | ESD | 2000 | V |
| Operating Temperature | Topr | -40 ~ +85 | °C |
| Storage Temperature | Tstg | -40 ~ +90 | °C |
| Soldering Temperature | Tsol | Reflow Soldering : 260 °C for 10 sec. Hand Soldering : 350 °C for 3 sec. | |

Electro-Optical Characteristics (Ta=25°C)

| Parameter | Symbol | Min. | Typ. | Max. | Units | Condition |
|--------------------|----------------|------|-------|------|-------|----------------------|
| Luminous Intensity | I _v | 1000 | ----- | 1800 | mcd | I _F =20mA |
| Viewing Angle | 2 θ 1/2 | -- | 120 | -- | deg | I _F =20mA |
| Forward Voltage | V _F | 2.70 | ----- | 3.50 | V | I _F =20mA |

Notes:

- 1.Tolerance of Luminous Intensity ±11%
- 2.Tolerance of Forward Voltage ±0.05V

Chromaticity Coordinates Specifications for Bin Grading

I_F=20mA

| Bin Code | CIE_x | CIE_y | Bin Code | CIE_x | CIE_y |
|----------|-------|-------|----------|-------|-------|
| CC0-1 | 0.330 | 0.339 | CC0-2 | 0.338 | 0.345 |
| | 0.330 | 0.360 | | 0.335 | 0.360 |
| | 0.335 | 0.360 | | 0.340 | 0.360 |
| | 0.338 | 0.345 | | 0.345 | 0.350 |
| CC0-3 | 0.33 | 0.318 | CC0-4 | 0.340 | 0.329 |
| | 0.33 | 0.339 | | 0.338 | 0.345 |
| | 0.338 | 0.345 | | 0.345 | 0.350 |
| | 0.340 | 0.329 | | 0.350 | 0.340 |

*The C.I.E. 1931 chromaticity diagram (Tolerance ±0.01).

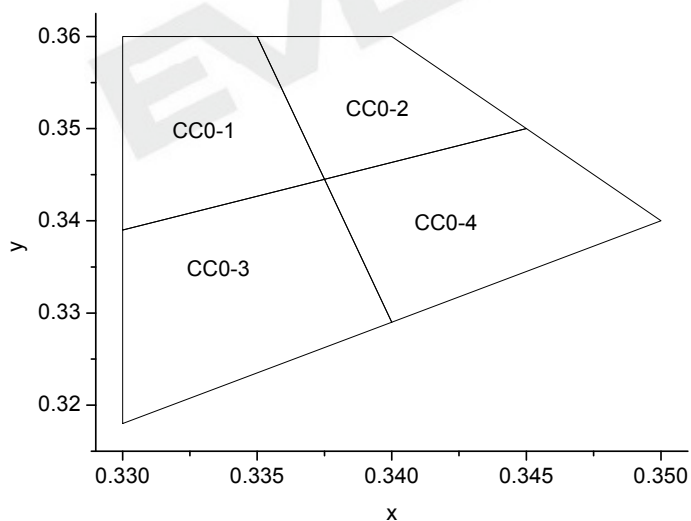

Reliability Test Items And Conditions

The reliability of products shall be satisfied with items listed below.

Confidence level : 90%

LTPD : 10%

| No. | Items | Test Condition | Test Hours/Cycles | Sample Size | Ac/Re |
|-----|----------------------------------|--|-------------------|-------------|-------|
| 1 | Reflow Soldering | Temp. : 260°C±5°C Min. 5sec. | 6 min | 22 PCS. | 0/1 |
| 2 | Temperature Cycle | H : +100°C 15min § 5 min L : -40°C 15min | 300 Cycles | 22 PCS. | 0/1 |
| 3 | Thermal Shock | H : +100°C 5min § 10 sec L : -10°C 5min | 300 Cycles | 22 PCS. | 0/1 |
| 4 | High Temperature Storage | Temp. : 100°C | 1000 Hrs. | 22 PCS. | 0/1 |
| 5 | Low Temperature Storage | Temp. : -40°C | 1000 Hrs. | 22 PCS. | 0/1 |
| 6 | DC Operating Life | IF = 20 mA / 25°C | 1000 Hrs. | 22 PCS. | 0/1 |
| 7 | High Temperature / High Humidity | 85°C/ 85%RH | 1000 Hrs. | 22 PCS. | 0/1 |

Package Dimensions

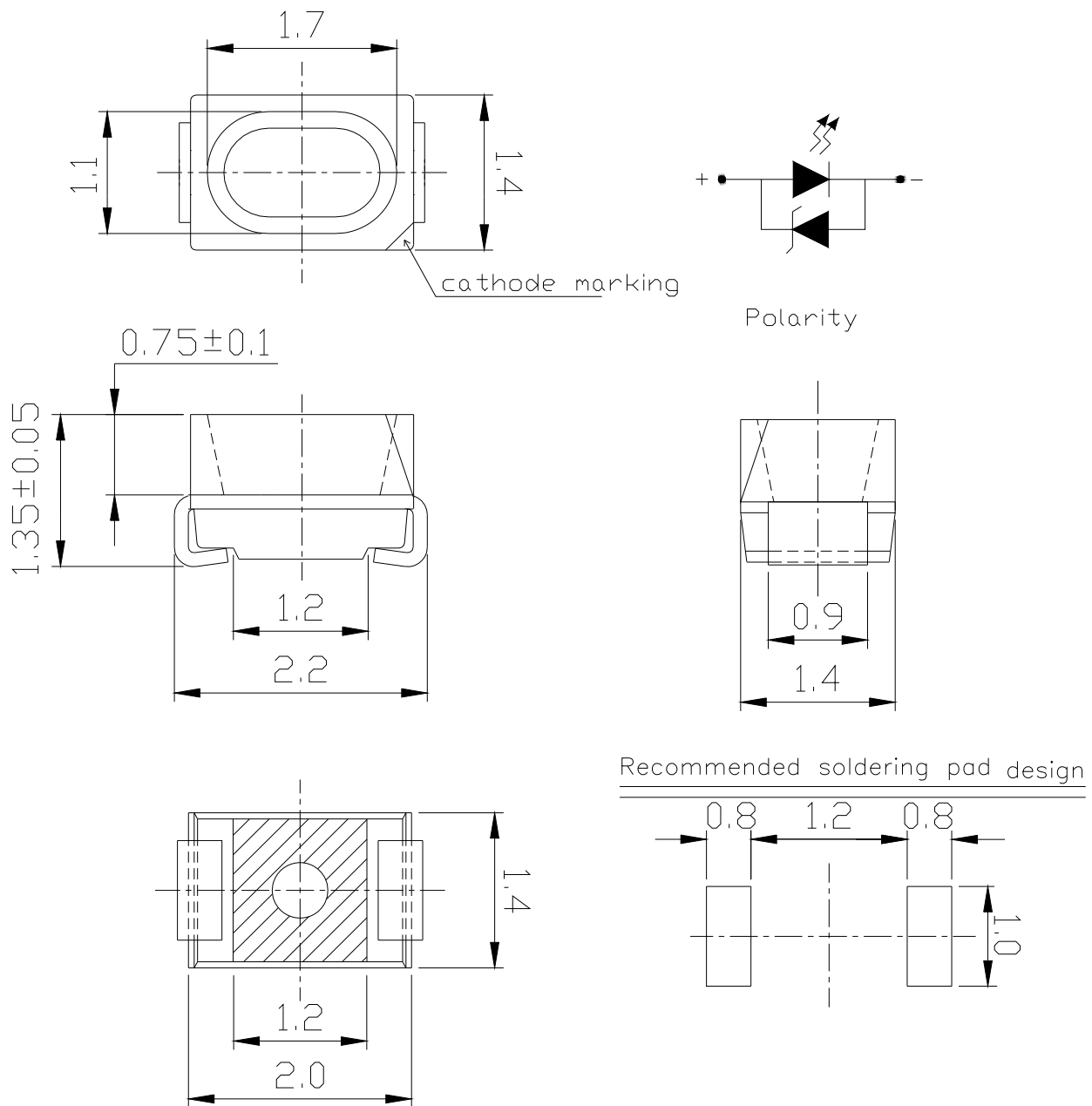

Note: The tolerances unless mentioned is ± 0.1 mm, Unit = mm

Typical Electro-Optical Characteristics Curves

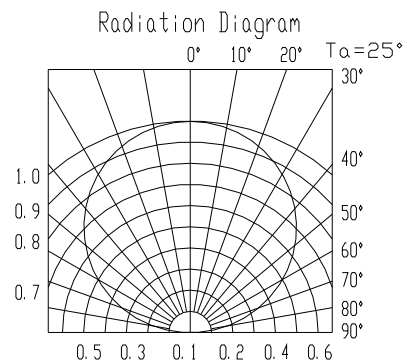
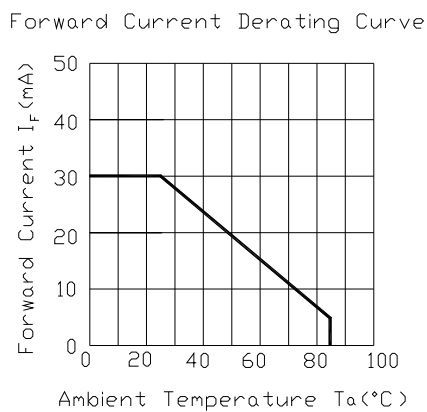
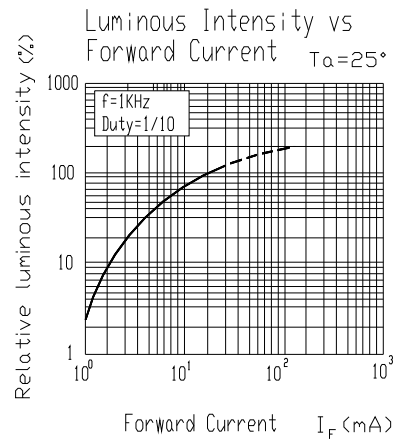
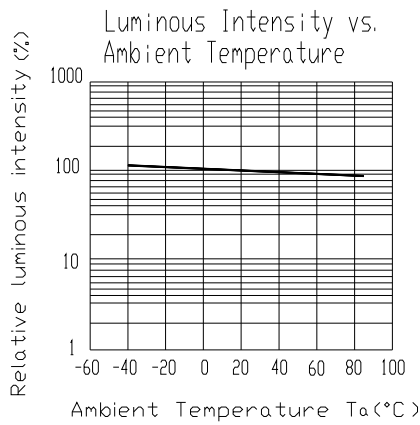
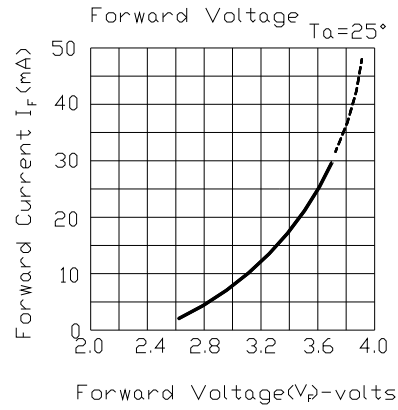
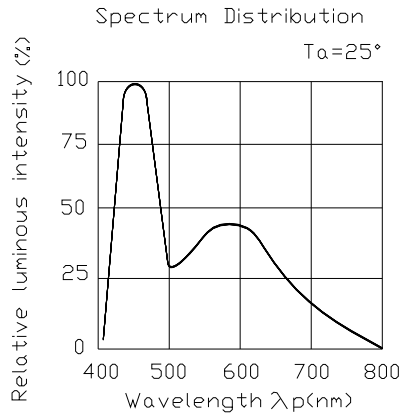

Label explanation

CAT: Luminous Intensity Rank

HUE: Chromaticity Coordinates

REF: Forward Voltage Rank

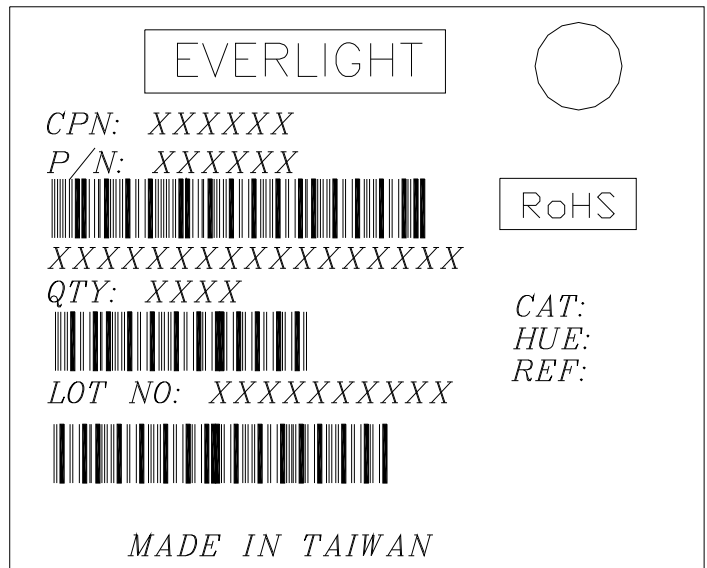

Reel Dimensions

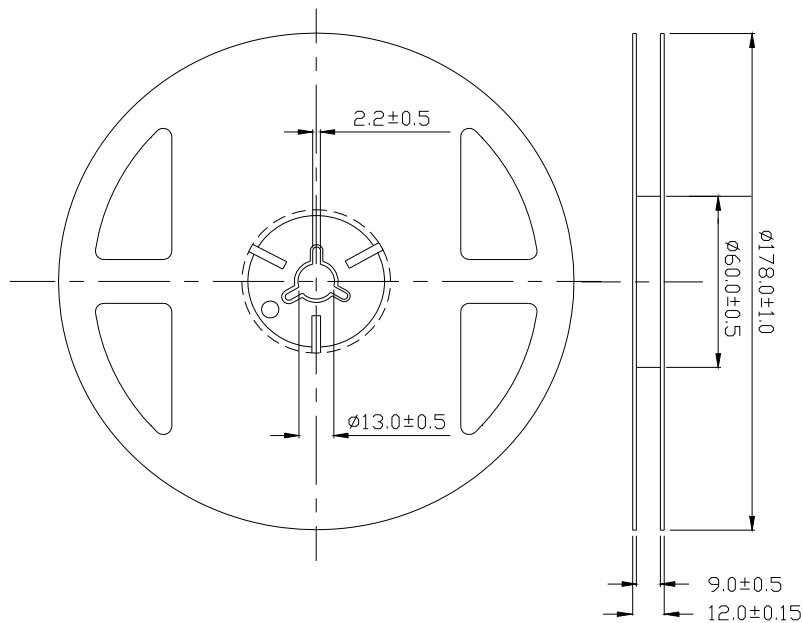

Note: The tolerances unless mentioned is ± 0.1 mm ,Unit = mm

Carrier Tape Dimensions: Loaded quantity 2000 PCS per reel.

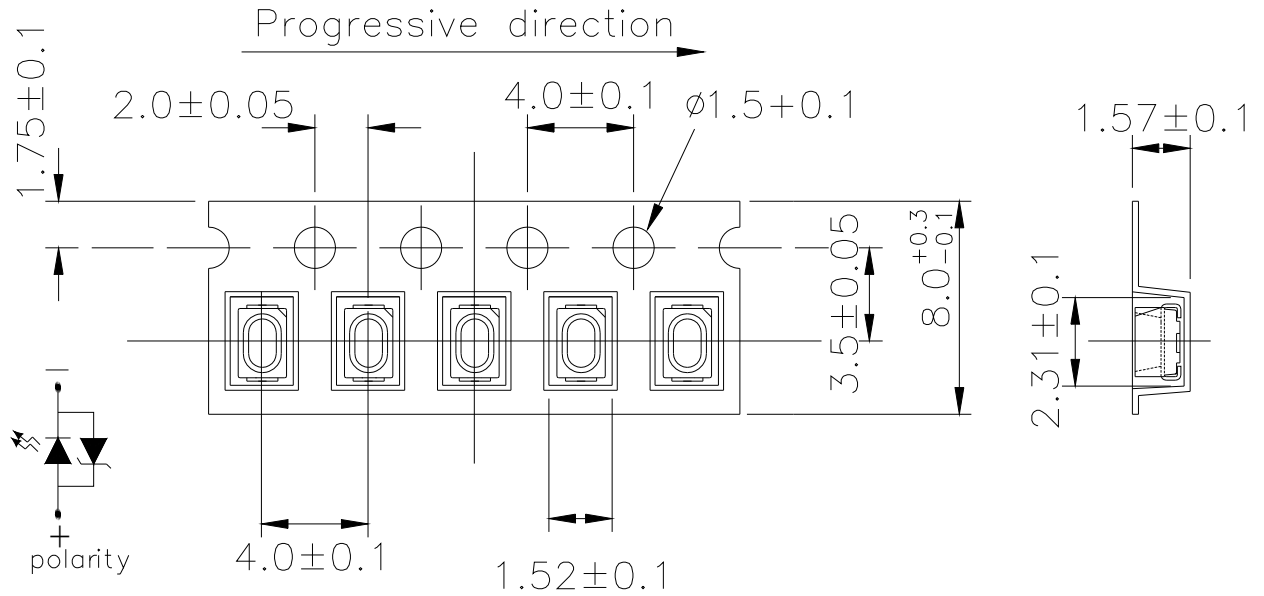

Note: The tolerances unless mentioned is ± 0.1 mm, Unit = mm

Moisture Resistant Packaging

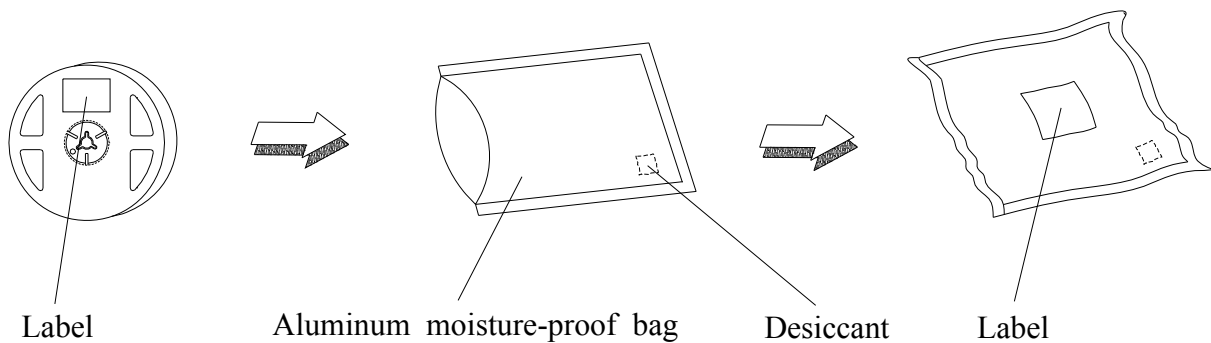

Precautions For Use

1. Over-current-proof

Customer must apply resistors for protection, otherwise slight voltage shift will cause big current change (Burn out will happen).

2. Storage

2.1 Do not open moisture proof bag before the products are ready to use.

2.2 Before opening the package: The LEDs should be kept at 30°C or less and 90%RH or less.

2.3 After opening the package: The LED's floor life is 1 year under 30°C or less and 60% RH or less.

If unused LEDs remain, it should be stored in moisture proof packages.

2.4 If the moisture absorbent material (silica gel) has faded away or the LEDs have exceeded the storage time, baking treatment should be performed using the following conditions.

Baking treatment : 60±5°C for 24 hours.

3. Soldering Condition

3.1 Pb-free solder temperature profile

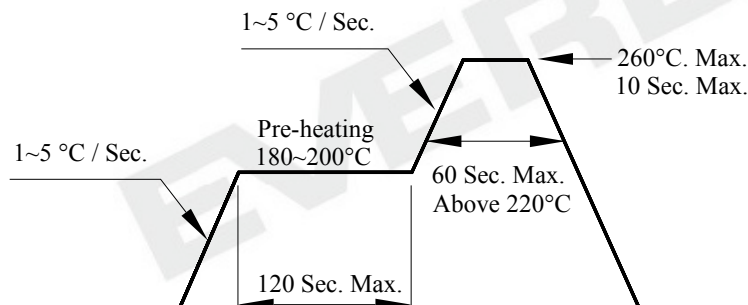

3.2 Reflow soldering should not be done more than two times.

3.3 When soldering, do not put stress on the LEDs during heating.

3.4 After soldering, do not warp the circuit board.

4. Soldering Iron

Each terminal is to go to the tip of soldering iron temperature less than 350°C for 3 seconds within once in less than the soldering iron capacity 25W. Leave two seconds and more intervals, and do soldering of each terminal. Be careful because the damage of the product is often started at the time of the hand solder.

5.Repairing

Repair should not be done after the LEDs have been soldered. When repairing is unavoidable, a double-head soldering iron should be used (as below figure). It should be confirmed beforehand whether the characteristics of the LEDs will or will not be damaged by repairing.

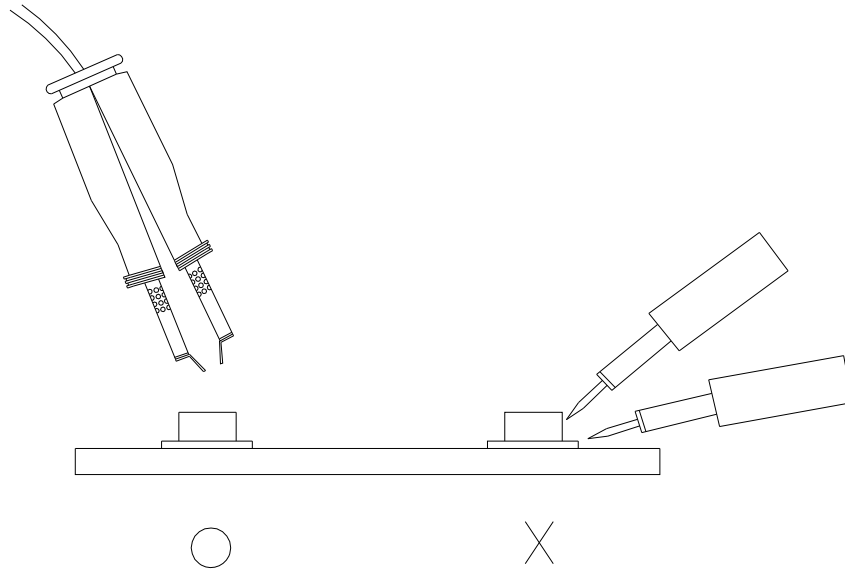

DISCLAIMER

1. EVERLIGHT reserves the right(s) on the adjustment of product material mix for the specification.
2. The product meets EVERLIGHT published specification for a period of twelve (12) months from date of shipment.
3. The graphs shown in this datasheet are representing typical data only and do not show guaranteed values.
4. When using this product, please observe the absolute maximum ratings and the instructions for using outlined in these specification sheets. EVERLIGHT assumes no responsibility for any damage resulting from the use of the product which does not comply with the absolute maximum ratings and the instructions included in these specification sheets.
5. These specification sheets include materials protected under copyright of EVERLIGHT. Reproduction in any form is prohibited without obtaining EVERLIGHT's prior consent.
6. This product is not intended to be used for military, aircraft, automotive, medical, life sustaining or life saving applications or any other application which can result in human injury or death. Please contact authorized Everlight sales agent for special application request.