

### Top view LED EAPL3528RGA3



#### Features

- P-LCC-4 package
- Optical indicator
- Colorless clear window
- Ideal for backlight and light pipe application
- Inter reflector
- Wide viewing angle
- Suitable for vapor-phase reflow .
- Computable with automatic placement equipment
- Available on tape and reel (8mm Tape)
- Pb-free
- The product itself will remain within RoHS compliant version

#### Descriptions

The EAPL3528RGA3 series is available in soft orange, green, blue and yellow. Due to the package design, the LED has wide viewing angle and optimized light coupling by inter reflector. This feature makes ideal for light pipe application. The low current requirement makes this device ideal for portable equipment or any other application where power is at a premium.

#### Applications

- Telecommunication: indicator and backlighting in telephone and fax
- Flat backlight for LCD's, switches and symbols
- Light pipe application
- General use

### Device Selection Guide

| Chip |          |                        | Resin Color |
|------|----------|------------------------|-------------|
| Type | Material | Emitted Color          |             |
| B8   | AlGaInP  | Deep - Red             | Water Clear |
| G6   | AlGaInP  | Brilliant Yellow Green |             |

### Bin Range of Luminous Intensity

| Symbol | Bin Code | Min. | Max. | Unit | Condition           |
|--------|----------|------|------|------|---------------------|
| R8     | G1       | 1.80 | 2.30 | mcd  | I <sub>F</sub> =2mA |
|        | G2       | 2.30 | 2.80 |      |                     |
|        | H1       | 2.80 | 3.60 |      |                     |
|        | H2       | 3.60 | 4.50 |      |                     |
|        | J1       | 4.50 | 5.80 |      |                     |
| G6     | G1       | 1.80 | 2.30 |      |                     |
|        | G2       | 2.30 | 2.80 |      |                     |
|        | H1       | 2.80 | 3.60 |      |                     |
|        | H2       | 3.60 | 4.50 |      |                     |

### Bin Range of Dominant Wavelength

| Symbol | Bin Code | Min.  | Max.  | Unit | Condition           |
|--------|----------|-------|-------|------|---------------------|
| R8     | FF4      | 636   | 641   | nm   | I <sub>F</sub> =2mA |
|        | FF5      | 641   | 646   |      |                     |
| G6     | C15      | 567.5 | 569.5 |      |                     |
|        | C16      | 569.5 | 571.5 |      |                     |
|        | C17      | 571.5 | 573.5 |      |                     |
|        | C18      | 573.5 | 575.5 |      |                     |

#### Notes:

1. Tolerance of Luminous Intensity  $\pm 11\%$
2. Tolerance of Dominant Wavelength  $\pm 1\text{nm}$

### Absolute Maximum Ratings (Ta=25°C)

| Parameter                                  | Symbol           | Rating  | Unit |
|--|------------------|---|------|
| Reverse Voltage                            | V <sub>R</sub>   | 5   | V    |
| Forward Current                            | I <sub>F</sub>   | R8  | 25   |
|  |                  | G6  | 25   |
| Peak Forward Current<br>(Duty 1/10 @ 1KHz) | I <sub>FP</sub>  | R8  | 60   |
|  |                  | G6  | 60   |
| Power Dissipation                          | P <sub>d</sub>   | R8  | 60   |
|  |                  | G6  | 60   |
| Electrostatic Discharge(HBM)               | ESD              | 2000  | V    |
| Operating Temperature                      | T <sub>opr</sub> | -40 ~ +85   | °C   |
| Storage Temperature                        | T <sub>stg</sub> | -40~ +90  | °C   |
| Soldering Temperature                      | T <sub>sol</sub> | Reflow Soldering : 260 °C for 10 sec.<br>Hand Soldering : 350 °C for 3 sec. |      |

### Electro-Optical Characteristics (Ta=25°C)

| Parameter                    | Symbol            | Min.  | Typ.  | Max.  | Unit  | Condition           |
|------------------------------|-------------------|-------|-------|-------|-------|---------------------|
| Luminous Intensity           | I <sub>v</sub>    | R8    | 1.8   | ----- | 5.8   | mcd                 |
|                              |                   | G6    | 1.8   | ----- | 4.5   |                     |
| Peak Wavelength              | λ <sub>p</sub>    | R8    | ----- | 650   | ----- | nm                  |
|                              |                   | G6    | ----- | 575   | ----- |                     |
| Dominant Wavelength          | λ <sub>d</sub>    | R8    | 636   | ----- | 646   | nm                  |
|                              |                   | G6    | 567.5 | ----- | 575.5 |                     |
| Spectrum Radiation Bandwidth | Δλ                | R8    | ----- | 20    | ----- | nm                  |
|                              |                   | G6    | ----- | 20    | ----- |                     |
| Forward Voltage              | V <sub>F</sub>    | R8    | ----- | 2.0   | 2.4   | V                   |
|                              |                   | G6    | ----- | 2.0   | 2.4   |                     |
| Viewing Angle                | 2θ <sub>1/2</sub> | ----- | 120   | ----- | deg   | I <sub>F</sub> =2mA |
| Reverse Current              | I <sub>R</sub>    | ----- | ----- | 10    | μA    |                     |

**Notes:**

- 1.Tolerance of Luminous Intensity ±11%
- 2.Tolerance of Dominant Wavelength ±1.0nm

### Typical Electro-Optical Characteristics Curves(R8)

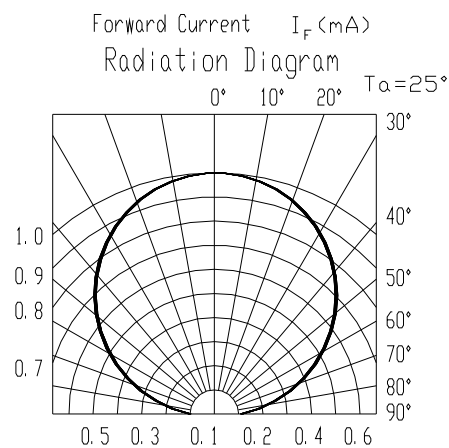
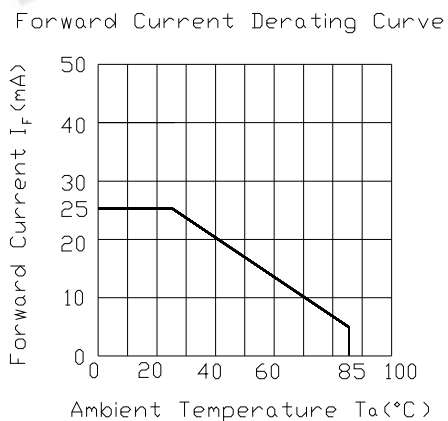
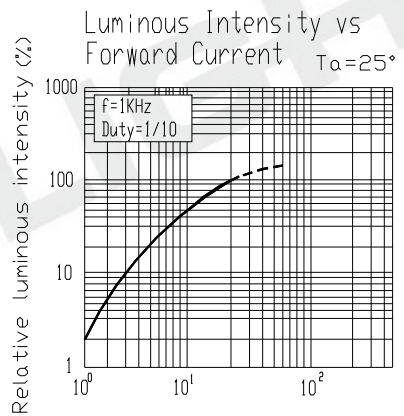
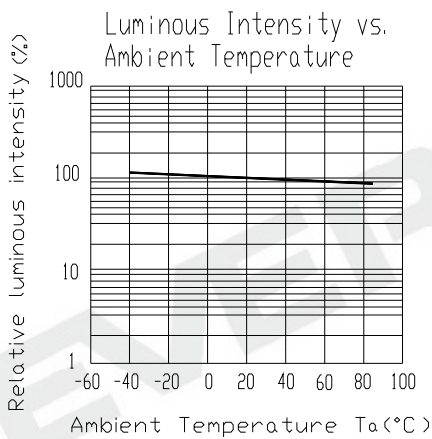
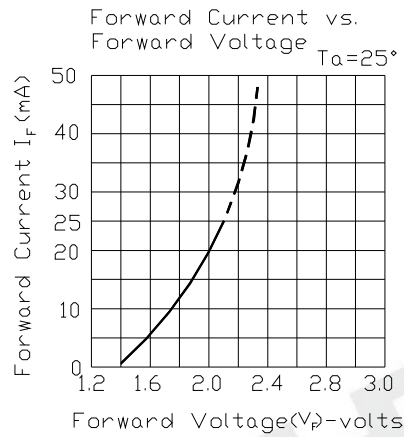
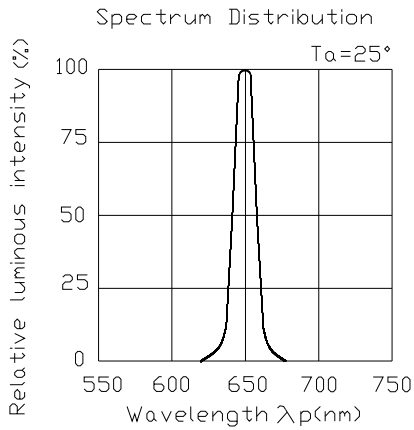

### Typical Electro-Optical Characteristics Curves(G6)

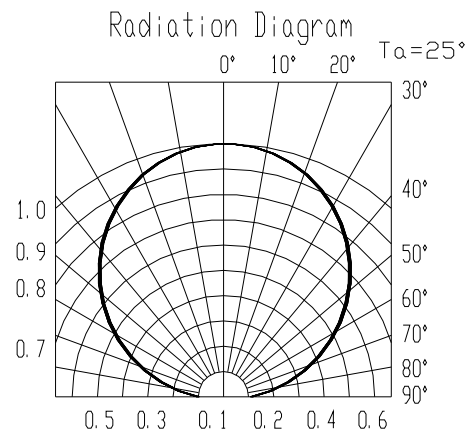
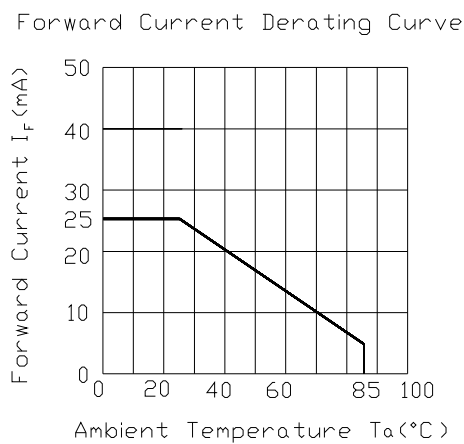
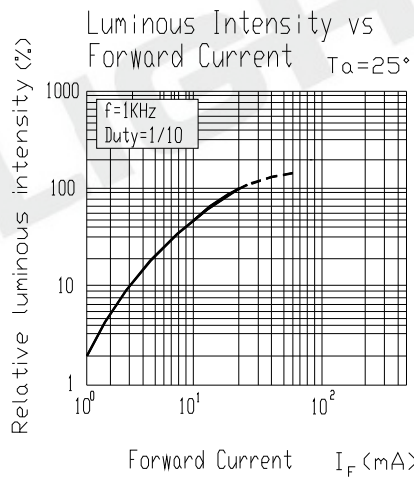
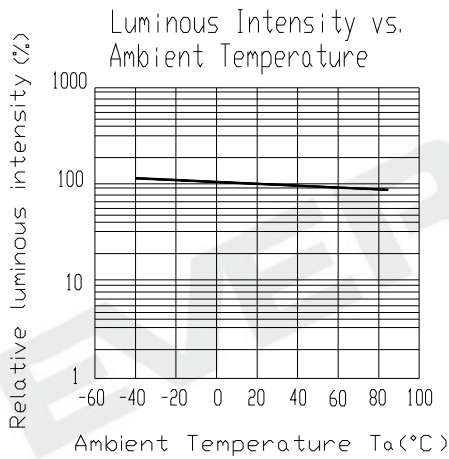
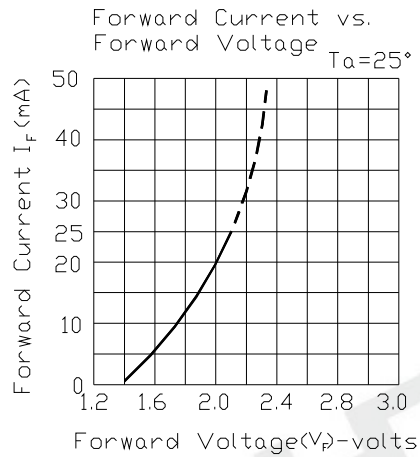
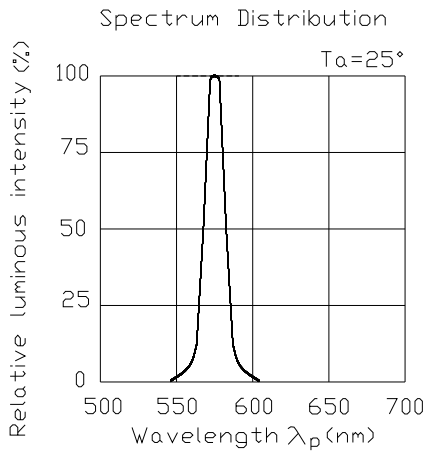

**Package Dimensions**

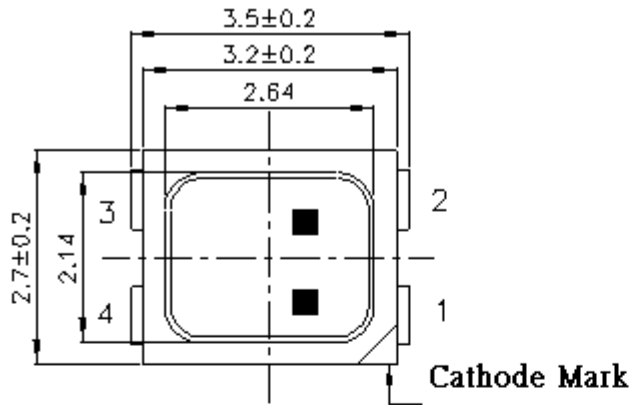

Polarity

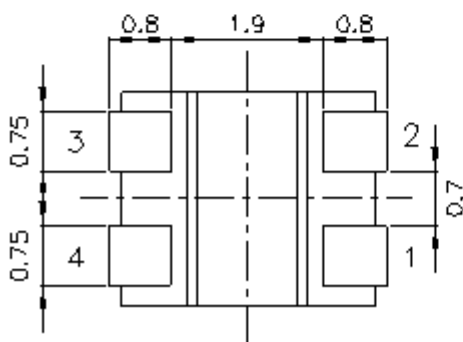
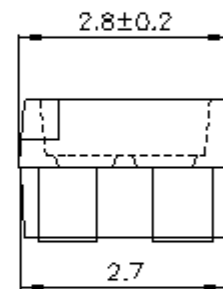
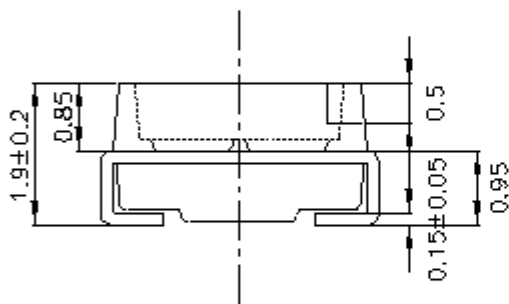

Recommended Solder Pad

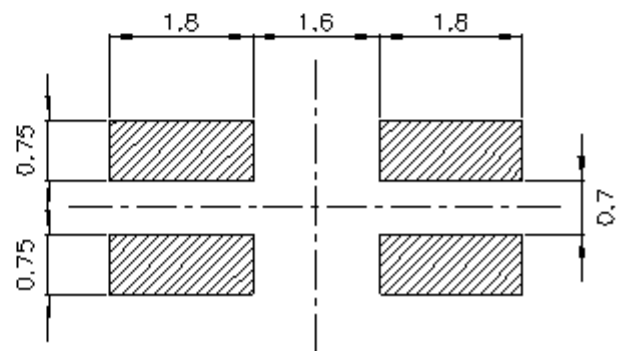

**Note:** The tolerances unless mentioned is  $\pm 0.1\text{mm}$  ;Unit = mm

**Label Explanation**

CAT: Luminous Intensity Rank  
 HUE: Chromaticity Coordinates  
 REF: Forward Voltage Rank

|   |           |                   |          |
|---|-----------|-------------------|----------|
| RoHS  | <b>Pb</b> | <b>EVERLIGHT</b>  | <b>5</b> |
| CPN: XXXXXXXXXXXXXXXXXXXXXXXX                       |           |                   |          |
| XXXXXXXXXX-XXXXXXXXXX-XXXXXXXXXX-XXXXX-----XXXXXXXX |           |                   |          |
| P/N: XXXXXXXXXXXX                                   |           |                   |          |
| XXXXXXXXXX-XXXXXXXXXX-XXXXXXXXXX-XXXXX-XXXXXX       |           |                   |          |
| LOT NO: Y150716XXX-XXXXXXXXXX-XXXXXXXXXX            |           |                   |          |
| QTY: 0123456789                                     |           | HUE: XXXXXXXXXXXX |          |
| CAT: XXXXXXXXXXXX                                   |           | REF: XXXXXXXXXXXX |          |
| REFERENCE: BTPYMMDDXXXXX                            |           |                   |          |
| MSL-X   |           | MADE IN XXXXXX    |          |



**Reel Dimensions**

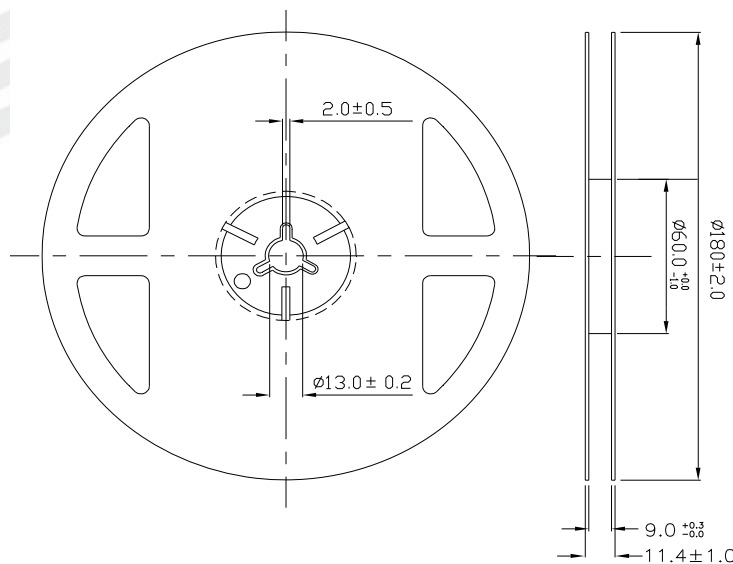

**Note:** The tolerances unless mentioned is  $\pm 0.1$ mm ,Unit = mm

**Carrier Tape Dimensions: Loaded quantity 2000 PCS per reel.**

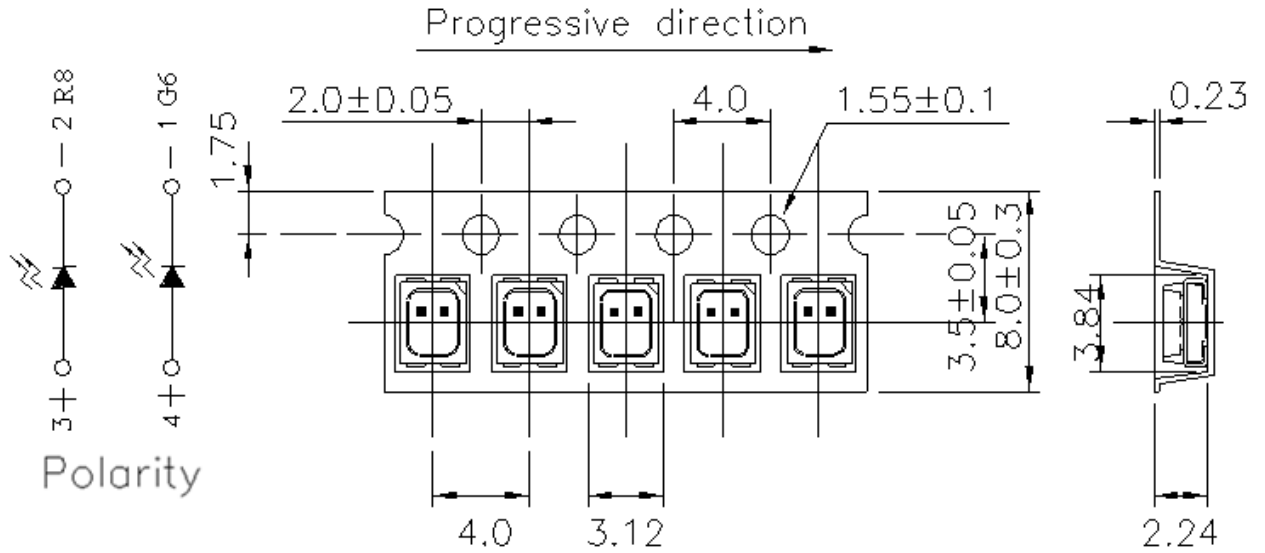

**Note:** The tolerances unless mentioned is  $\pm 0.1$ mm ,Unit = mm

**Moisture Resistant Packaging**

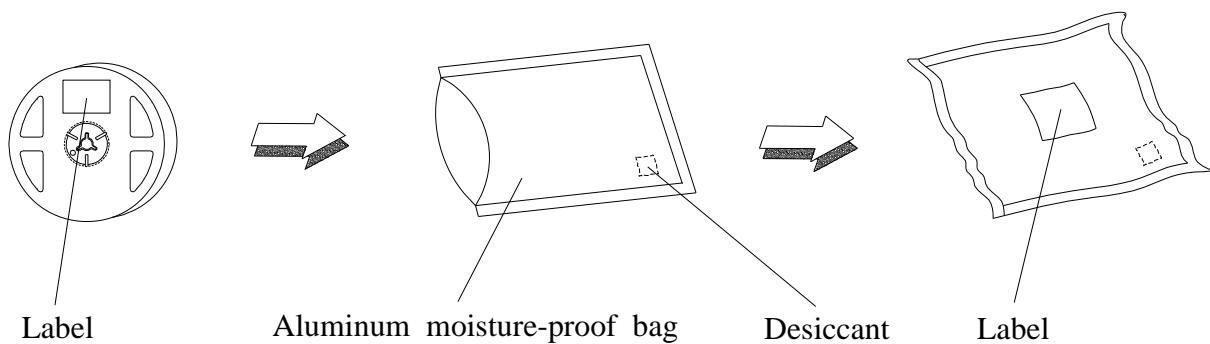



## Precautions for Use

### 1. Over-current-proof

1.1 Customer must apply resistors for protection, otherwise slight voltage shift will cause big current change ( Burn out will happen ).

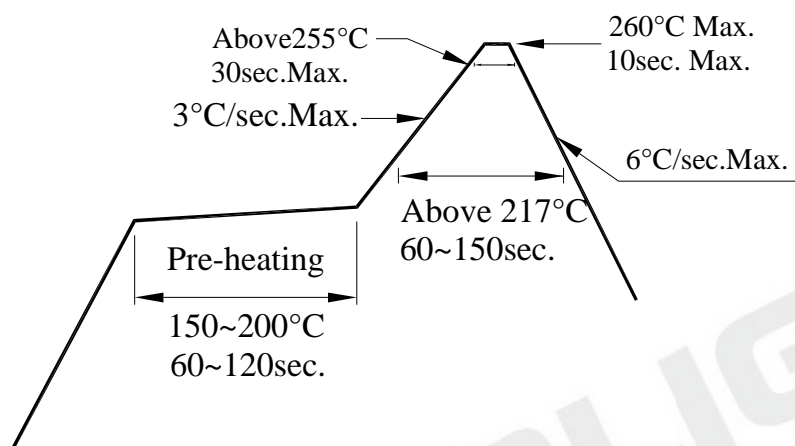

### 2. Storage

2.1 Moisture proof bag should only be opened immediately prior to usage.

2.2 Environment should be less than 30°C and 60% RH when moisture proof bag is opened.

2.3 After opening the package MSL Conditions stated on page 1 of this spec should not be exceeded.

2.4 If the moisture sensitivity card indicates higher than acceptable moisture, the component should be baked at min. 60deg +/-5deg for 24 hours.

### 3. Soldering Condition

3.1 Pb-free solder temperature profile

3.2 Reflow soldering should not be done more than two times.

3.3 When soldering, do not put stress on the LEDs during heating.

3.4 After soldering, do not warp the circuit board.

#### 4. Soldering Iron

Each terminal is to go to the tip of soldering iron temperature less than 350°C for 3 seconds within once in less than the soldering iron capacity 25W. Leave two seconds and more intervals, and do soldering of each terminal. Be careful because the damage of the product is often started at the time of the hand solder.

#### 5. Repairing

Repair should not be done after the LEDs have been soldered. When repairing is unavoidable, a double-head soldering iron should be used (as below figure). It should be confirmed beforehand whether the characteristics of the LEDs will or will not be damaged by repairing.

### **Application Restrictions**

High reliability applications such as military/aerospace, automotive safety/security systems, and medical equipment may require different product. If you have any concerns, please contact Everlight before using this product in your application. This specification guarantees the quality and performance of the product as an individual component. Do not use this product beyond the specification described in this document.

## **DISCLAIMER**

1. EVERLIGHT reserves the right(s) on the adjustment of product material mix for the specification.
2. The product meets EVERLIGHT published specification for a period of twelve (12) months from date of shipment.
3. The graphs shown in this datasheet are representing typical data only and do not show guaranteed values.
4. When using this product, please observe the absolute maximum ratings and the instructions for using outlined in these specification sheets. EVERLIGHT assumes no responsibility for any damage resulting from the use of the product which does not comply with the absolute maximum ratings and the instructions included in these specification sheets.
5. These specification sheets include materials protected under copyright of EVERLIGHT. Reproduction in any form is prohibited without obtaining EVERLIGHT's prior consent.
6. This product is not intended to be used for military, aircraft, automotive, medical, life sustaining or life saving applications or any other application which can result in human injury or death. Please contact authorized Everlight sales agent for special application request.