

### EAPL2214WA4

#### Features

- White SMT package
- Optical indicator
- Wide viewing angle
- Soldering methods: IR reflow soldering
- Available on tape and reel
- Pb-free
- The product itself will remain within RoHS compliant version.



#### Descriptions

The white LED which was fabricated using a blue LED and a phosphor, and the phosphor is excited by blue light and emits yellow fluorescence. The mixture of blue light and yellow light results in a white emission.

#### Applications

- Optical indicators
- Coupling into light guides
- Backlighting (LCD, cellular phones, switches, keys, displays, illuminated advertising, general lighting).
- Coupling into light guides, Interior automotive lighting (e.g. dashboard backlighting, etc.)

#### Device Selection Guide

Chip	Emitted Color	Resin Color
Material		
InGaN	White	Water Clear

### Package Outline Dimensions

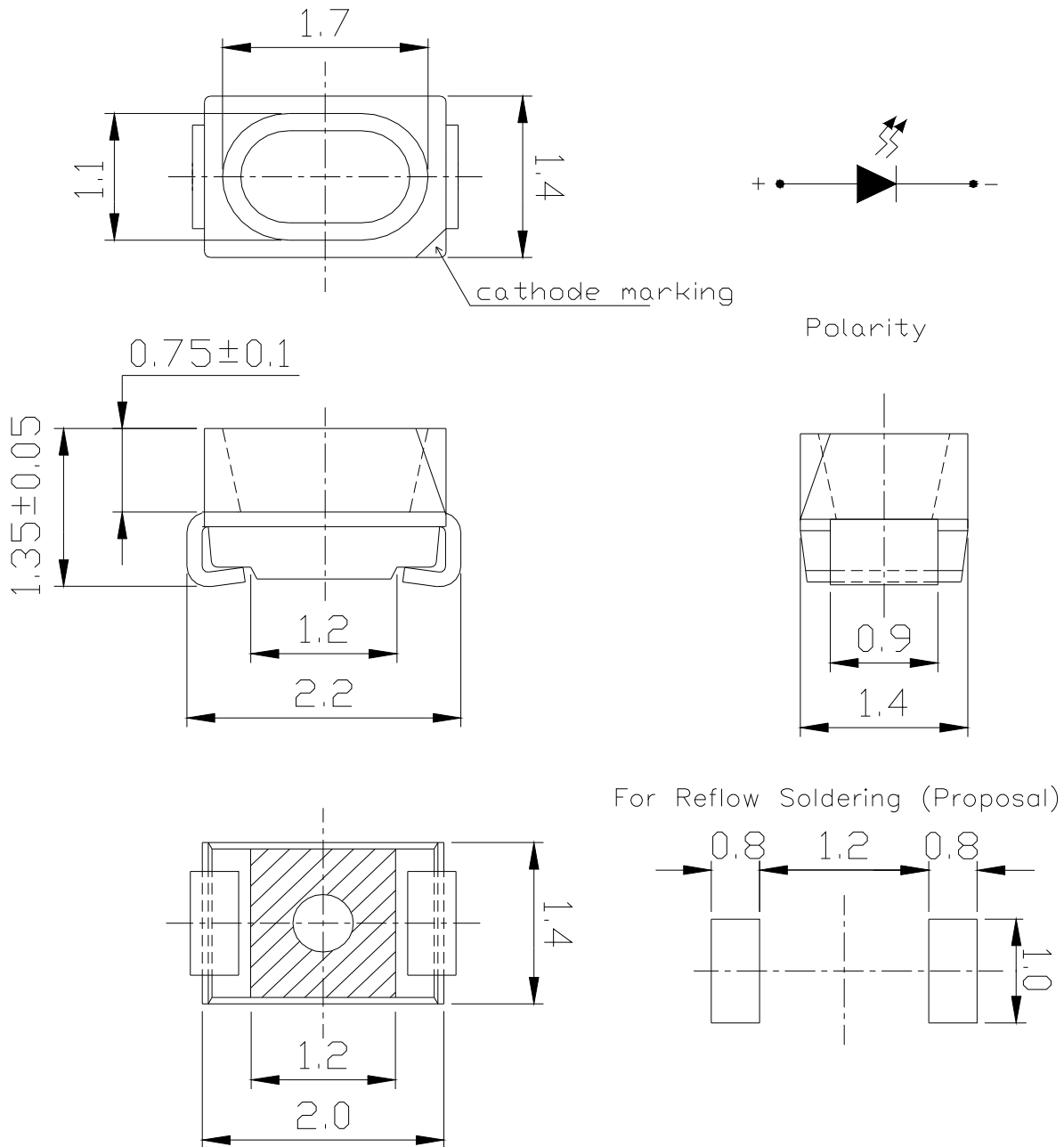

**Note:** Tolerance unless mentioned is  $\pm 0.1$  mm; Unit = mm

### Absolute Maximum Ratings (Ta=25°C)

Parameter	Symbol	Rating	Unit
Reverse Voltage	V <sub>R</sub>	5	V
Forward Current	I <sub>F</sub>	30	mA
Power Dissipation	P <sub>d</sub>	100	mW
Peak Forward Current (Duty 1/10 @1KHz)	I <sub>FP</sub>	110	mA
Electrostatic Discharge (HBM)	ESD	1000	V
Operating Temperature	Topr	-40 ~ +85	°C
Storage Temperature	Tstg	-40 ~ +90	°C
Soldering Temperature	Tsol	Reflow Soldering : 260 °C for 10 sec. Hand Soldering : 350 °C for 3 sec.	

### Electro-Optical Characteristics (Ta=25°C)

Parameter	Symbol	Min.	Typ.	Max.	Unit	Condition
Luminous Intensity	I <sub>v</sub>	1120	-----	2250	mcd	I <sub>F</sub> =20mA
Viewing Angle	2θ 1/2	-----	120	-----	deg	I <sub>F</sub> =20mA
Forward Voltage	V <sub>F</sub>	2.70	-----	3.50	V	I <sub>F</sub> =20mA
Reverse Current	I <sub>R</sub>	-----	-----	50	μA	V <sub>R</sub> =5V

**Notes:**

1. Tolerance of Luminous Intensity: ±11%
2. Tolerance of Forward Voltage: ±0.1V

### Bin Range of Luminous Intensity

Bin Code	Min.	Max.	Unit	Condition
W1	1120	1420	mcd	I <sub>F</sub> =20mA
W2	1420	1800		
X1	1800	2250		

### Bin Range of Forward Voltage

Group	Bin	Min	Max	Unit	Condition
F	10	2.70	2.90	V	I <sub>F</sub> =20mA
	11	2.90	3.10		
	12	3.10	3.30		
	13	3.30	3.50		

**Notes:**

1. Tolerance of Luminous Intensity:  $\pm 11\%$
2. Tolerance of Forward Voltage:  $\pm 0.1V$

**Bin Range of Chromaticity Coordinates**

**I<sub>F</sub>=20mA**

Group	Bin Code	CIE_x	CIE_y	Bin Code	CIE_x	CIE_y
K	B5-1	0.2915	0.2855	B5-2	0.3003	0.2950
		0.2870	0.2950		0.2970	0.3050
		0.2970	0.3050		0.3070	0.3150
		0.3003	0.2950		0.3090	0.3045
	B5-3	0.2960	0.2760	B5-4	0.3035	0.2850
		0.2915	0.2855		0.3003	0.2950
		0.3003	0.2950		0.3090	0.3045
		0.3035	0.2850		0.3110	0.2940

**Notes:** Tolerance of Chromaticity Coordinates : ±0.01

**The C.I.E. 1931 Chromaticity Diagram**

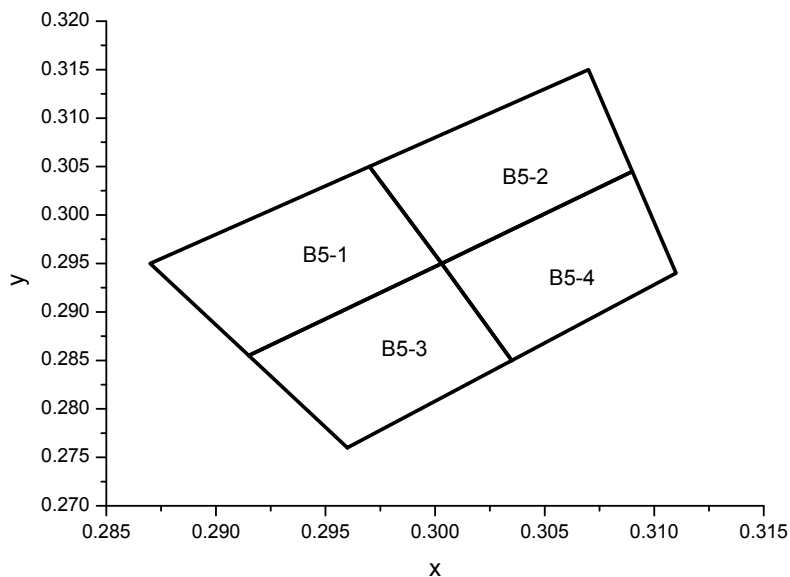

## Typical Electro-Optical Characteristics Curves

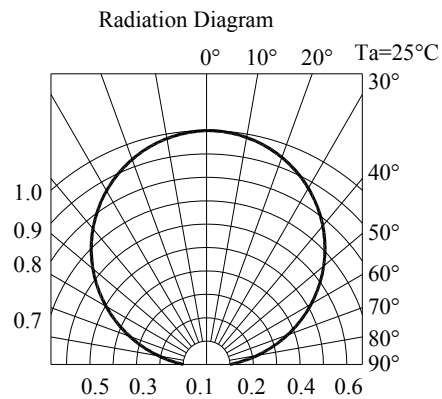
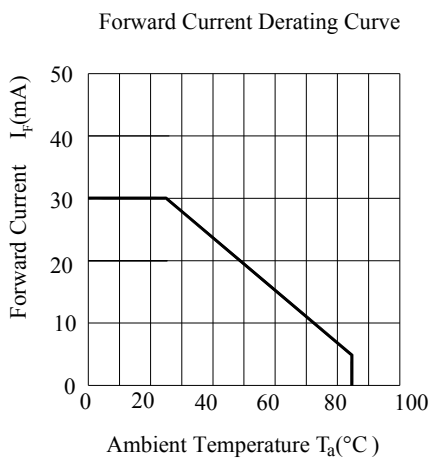
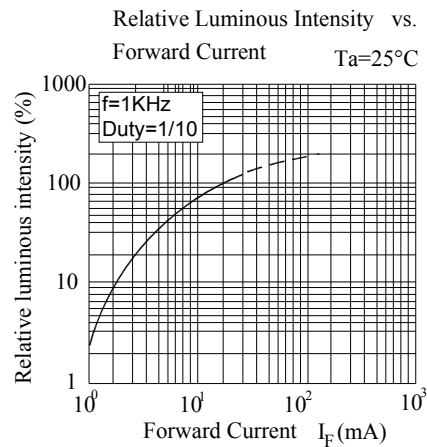
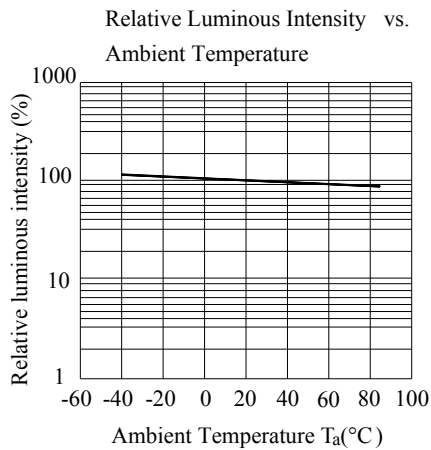
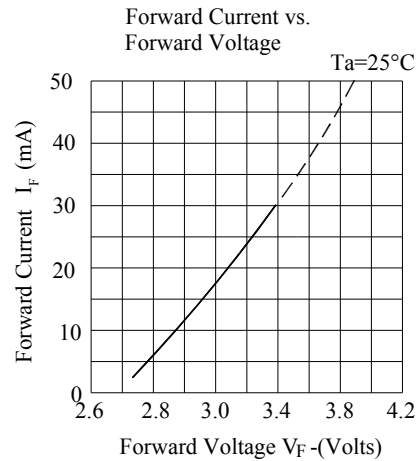
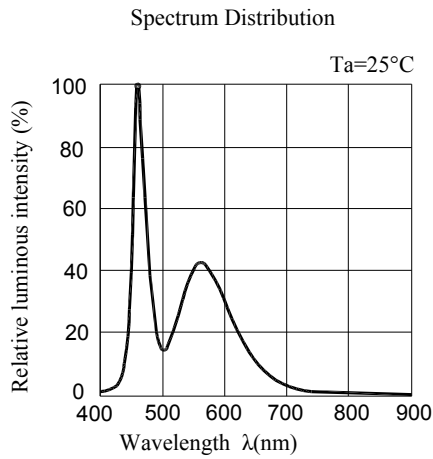

### Label Explanation

**CAT:** Luminous Intensity Rank

**HUE:** Chromaticity Coordinates

**REF:** Forward Voltage Rank



### Reel Dimensions

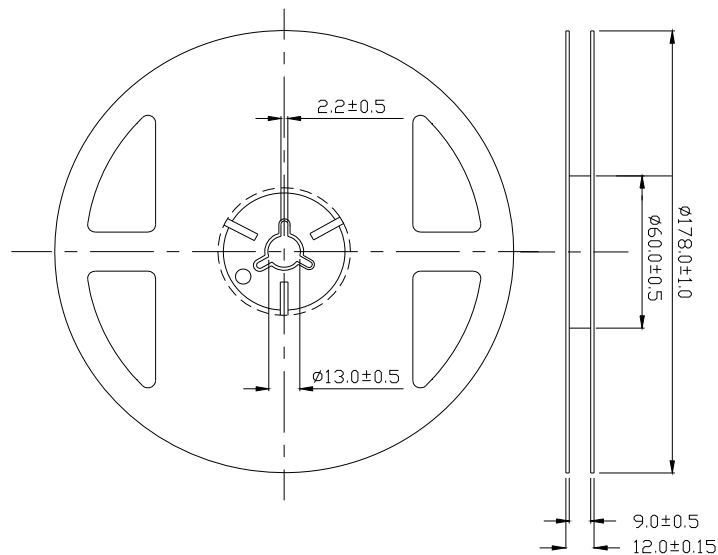

**Note:** Tolerance unless mentioned is  $\pm 0.1$ mm; Unit = mm

**Carrier Tape Dimensions: Loaded Quantity 2000 pcs Per Reel.**

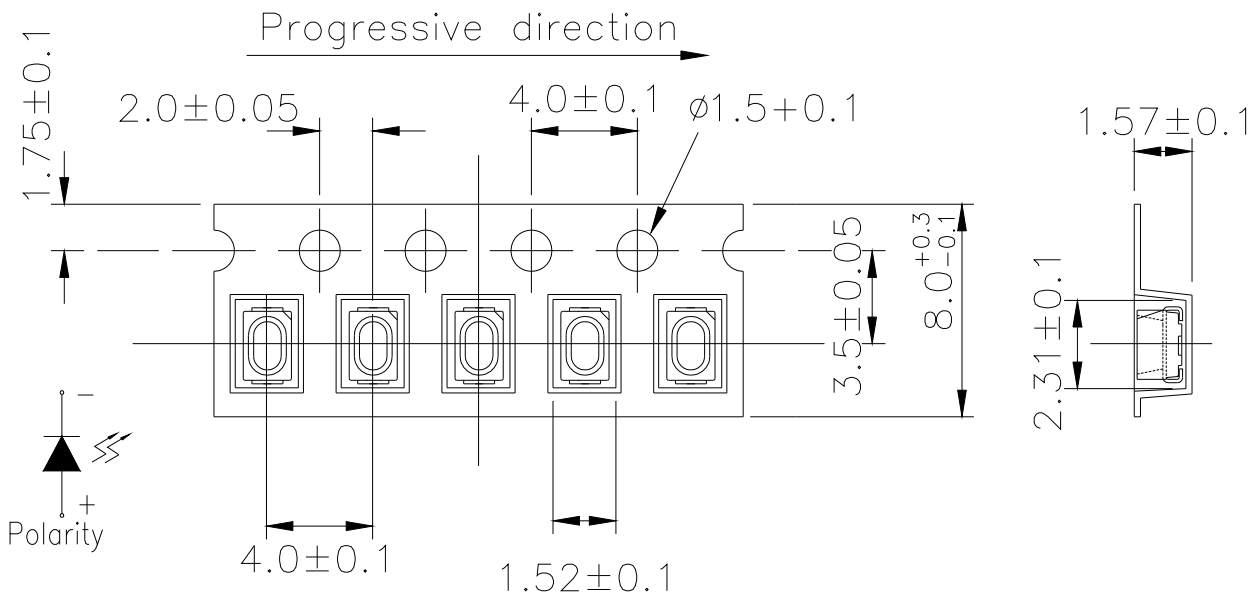

**Note:** Tolerance unless mentioned is ±0.1mm; Unit = mm

**Moisture Resistant Packaging**

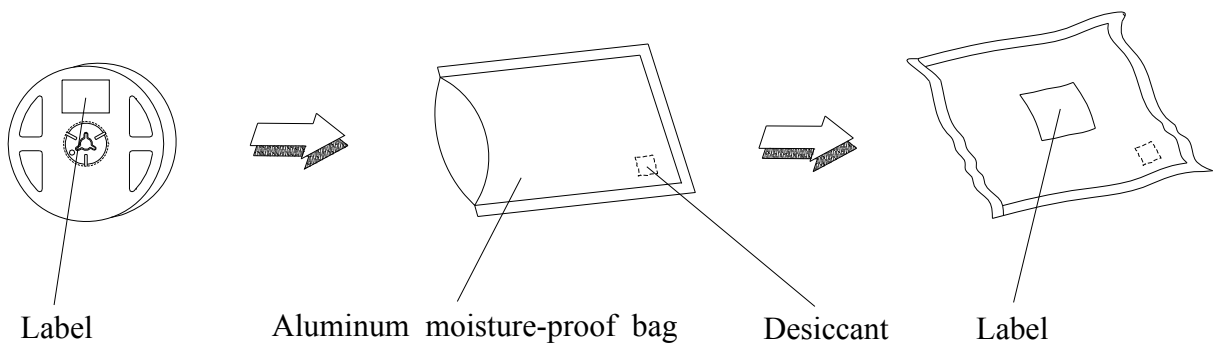



### Reliability Test Items and Conditions

The reliability of products shall be satisfied with items listed below.

Confidence level : 90%

LTPD : 10%

No.	Items	Test Condition	Test Hours/Cycles	Sample Size	Ac/Re
1	Reflow Soldering	Temp. : 260°C±5°C Min. 5sec.	6 min	22 PCS.	0/1
2	Temperature Cycle	H : +100°C 15min ∫ 5 min L : -40°C 15min	300 Cycles	22 PCS.	0/1
3	Thermal Shock	H : +100°C 5min ∫ 10 sec L : -10°C 5min	300 Cycles	22 PCS.	0/1
4	High Temperature Storage	Temp. : 100°C	1000 Hrs.	22 PCS.	0/1
5	Low Temperature Storage	Temp. : -40°C	1000 Hrs.	22 PCS.	0/1
6	DC Operating Life	I <sub>F</sub> = 20 mA	1000 Hrs.	22 PCS.	0/1
7	High Temperature / High Humidity	85°C / 85%RH	1000 Hrs.	22 PCS.	0/1

## Precautions for Use

### 1. Over-current-proof

Customer must apply resistors for protection; otherwise slight voltage shift will cause big current change (Burn out will happen).

### 2. Storage

2.1 Do not open moisture proof bag before the products are ready to use.

2.2 Before opening the package: The LEDs should be kept at 30°C or less and 90%RH or less.

2.3 After opening the package: The LED's floor life is 1 year under 30°C or less and 60% RH or less. If unused LEDs remain, it should be stored in moisture proof packages.

2.4 If the moisture absorbent material (silica gel) has faded away or the LEDs have exceeded the storage time, baking treatment should be performed using the following conditions.

Baking treatment: 60±5°C for 24 hours.

### 3. Soldering Condition

#### 3.1 Pb-free solder temperature profile

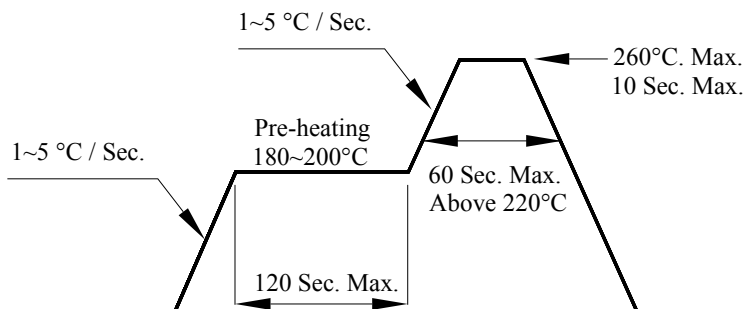

3.2 Reflow soldering should not be done more than two times.

3.3 When soldering, do not put stress on the LEDs during heating.

3.4 After soldering, do not warp the circuit board.

#### 4. Soldering Iron

Each terminal is to go to the tip of soldering iron temperature less than 280°C for 3 seconds within once in less than the soldering iron capacity 25W. Leave two seconds and more intervals, and do soldering of each terminal. Be careful because the damage of the product is often started at the time of the hand solder.

#### 5. Repairing

Repair should not be done after the LEDs have been soldered. When repairing is unavoidable, a double-head soldering iron should be used (as below figure). It should be confirmed beforehand whether the characteristics of the LEDs will or will not be damaged by repairing.

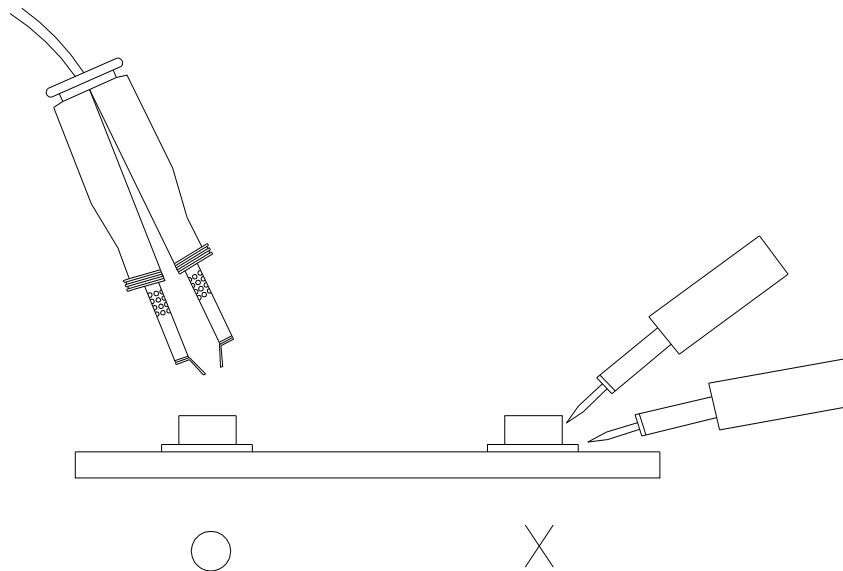

## **DISCLAIMER**

1. EVERLIGHT reserves the right(s) on the adjustment of product material mix for the specification.
2. The product meets EVERLIGHT published specification for a period of twelve (12) months from date of shipment.
3. The graphs shown in this datasheet are representing typical data only and do not show guaranteed values.
4. When using this product, please observe the absolute maximum ratings and the instructions for using outlined in these specification sheets. EVERLIGHT assumes no responsibility for any damage resulting from the use of the product which does not comply with the absolute maximum ratings and the instructions included in these specification sheets.
5. These specification sheets include materials protected under copyright of EVERLIGHT. Reproduction in any form is prohibited without obtaining EVERLIGHT's prior consent.
6. This product is not intended to be used for military, aircraft, automotive, medical, life sustaining or life saving applications or any other application which can result in human injury or death. Please contact authorized Everlight sales agent for special application request.