

**Technical Data Sheet**  
**Top View LEDs**

**62-217D/Y7TC-AX2Z11Z150/2T**

**Features**

- Top view white LED
- High luminous flux output
- High current capability
- White package
- Wide viewing angle
- Pb-free
- The product itself will remain within RoHS compliant version.



**Descriptions**

- Due to the package design, 62-217D has wide viewing angle, and white LEDs are devices which are materialized by combing blue chip and special phosphor. This feature makes the LED ideal for light guide application.

**Applications**

- Backlight for LCD Monitor/TV
- Light pipe application
- Indicator and backlight in office and family equipment
- General use

**Device Selection Guide**

Chip	Emitted Color	Resin Color
Material		
AlGaInP	Brilliant Yellow	Water Clear



**Technical Data Sheet**  
**Top View LEDs****62-217D/Y7TC-AX2Z11Z150/2T****Absolute Maximum Ratings (Ta=25°C)**

Parameter	Symbol	Rating	Unit
Reverse Voltage	V <sub>R</sub>	12	V
Forward Current	I <sub>F</sub>	150	mA
Peak Forward Current (Duty 1/10 @10ms)	I <sub>FP</sub>	300	mA
Power Dissipation	P <sub>d</sub>	500	mW
Electrostatic Discharge(HBM) <sup>*1</sup>	ESD	1000	V
Operating Temperature	T <sub>opr</sub>	-40 ~ +85	°C
Storage Temperature	T <sub>stg</sub>	-40 ~ +90	°C
Soldering Temperature	T <sub>sol</sub>	Reflow Soldering: 260 °C for 10 sec. Hand Soldering: 350 °C for 3 sec.	

**Notes:** 1. The products are sensitive to static electricity and must be carefully taken when handling products.

**Technical Data Sheet**  
**Top View LEDs****62-217D/Y7TC-AX2Z11Z150/2T****Electro-Optical Characteristics (Ta=25°C)**

Parameter	Symbol	Min.	Typ.	Max.	Unit	Condition
Luminous Intensity	$I_v$	2250	---	9100	mcd	$I_F = 150\text{mA}$
Viewing Angle	$2\theta_{1/2}$	---	120	---	deg	$I_F = 150\text{mA}$
Peak Wavelength	$\lambda_p$	---	591	---	nm	$I_F = 150\text{mA}$
Dominant Wavelength	$\lambda_d$	583	---	593	nm	$I_F = 150\text{mA}$
Spectrum Radiation Bandwidth	$\Delta\lambda$	---	20	---	nm	$I_F = 150\text{mA}$
Forward Voltage	$V_F$	1.7	---	2.7	V	$I_F = 150\text{mA}$
Reverse Current	$I_R$	---	---	10	$\mu\text{A}$	$V_R = 12\text{V}$
Temperature coefficient of $\lambda_p$	$TC_{\lambda_p}$	---	0.06	---	nm/K	$I_F = 150\text{mA}$
Temperature coefficient of $\lambda_d$	$TC_{\lambda_d}$	---	0.4	---	nm/K	$I_F = 150\text{mA}$
Temperature coefficient of $V_F$	$TC_V$	---	-2.3	---	mV/K	$I_F = 150\text{mA}$

Note:

1. Tolerance of Luminous Intensity:  $\pm 11\%$
2. Tolerance of Dominant Wavelength:  $\pm 1\text{nm}$
3. Tolerance of Forward Voltage:  $\pm 0.1\text{V}$

**Technical Data Sheet**  
**Top View LEDs****62-217D/Y7TC-AX2Z11Z150/2T****Bin Range of Luminous Intensity**

Bin Code	Min.	Max.	Unit	Condition
X2	2250	2850	mcd	I <sub>F</sub> =150mA
Y1	2850	3600		
Y2	3600	4500		
Z01	4500	5700		
Z02	5700	7200		
Z11	7200	9100		

Notes : Tolerance of Luminous Intensity : ±11%

**Bin Range of Dominant Wavelength**

Group	Bin Code	Min.	Max.	Unit	Condition
A	A1	583	587	nm	I <sub>F</sub> =150mA
	A2	587	590		
	A3	590	593		

Notes : Tolerance of Dominant Wavelength : ±1nm

**Bin Range of Forward Voltage**

Group	Bin Code	Min.	Max.	Unit	Condition
B	B1	1.70	1.95	V	I <sub>F</sub> =150mA
	B2	1.95	2.20		
	B3	2.20	2.45		
	B4	2.45	2.70		

Notes : Tolerance of Forward Voltage: ±0.05V

**Technical Data Sheet**  
**Top View LEDs**

**62-217D/Y7TC-AX2Z11Z150/2T**

**Typical Electro-Optical Characteristics Curves**  
**Typical Curve of Spectral Distribution**

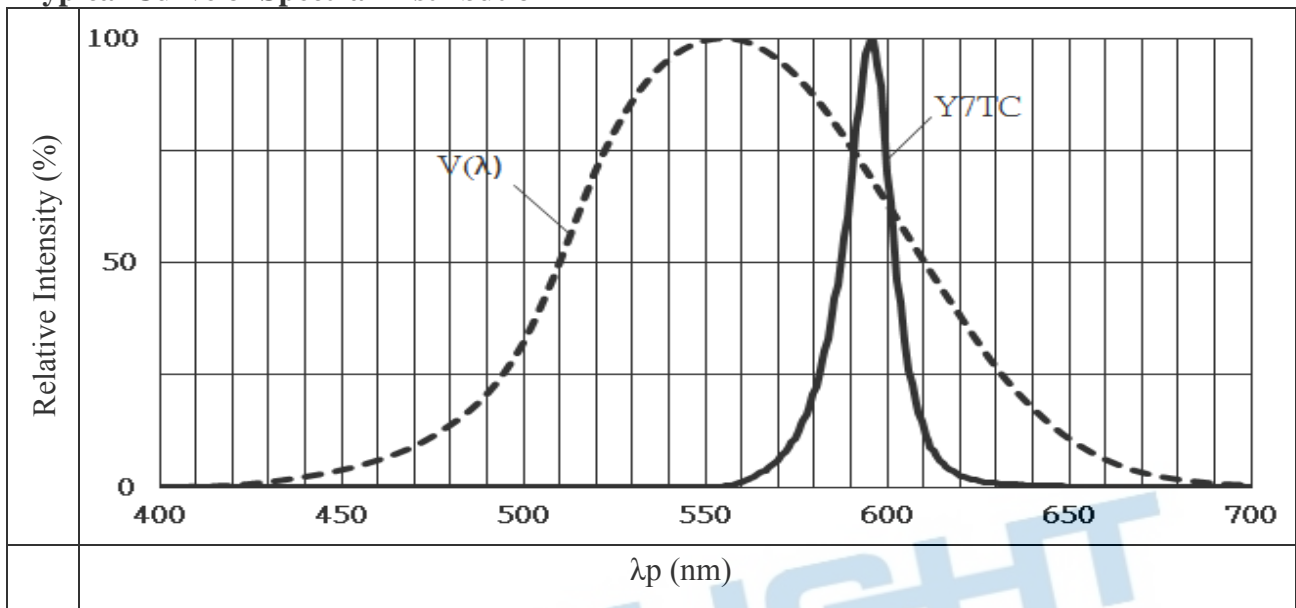

Note:  $V(\lambda)$ =Standard eye response curve

**Diagram Characteristics of Radiation**

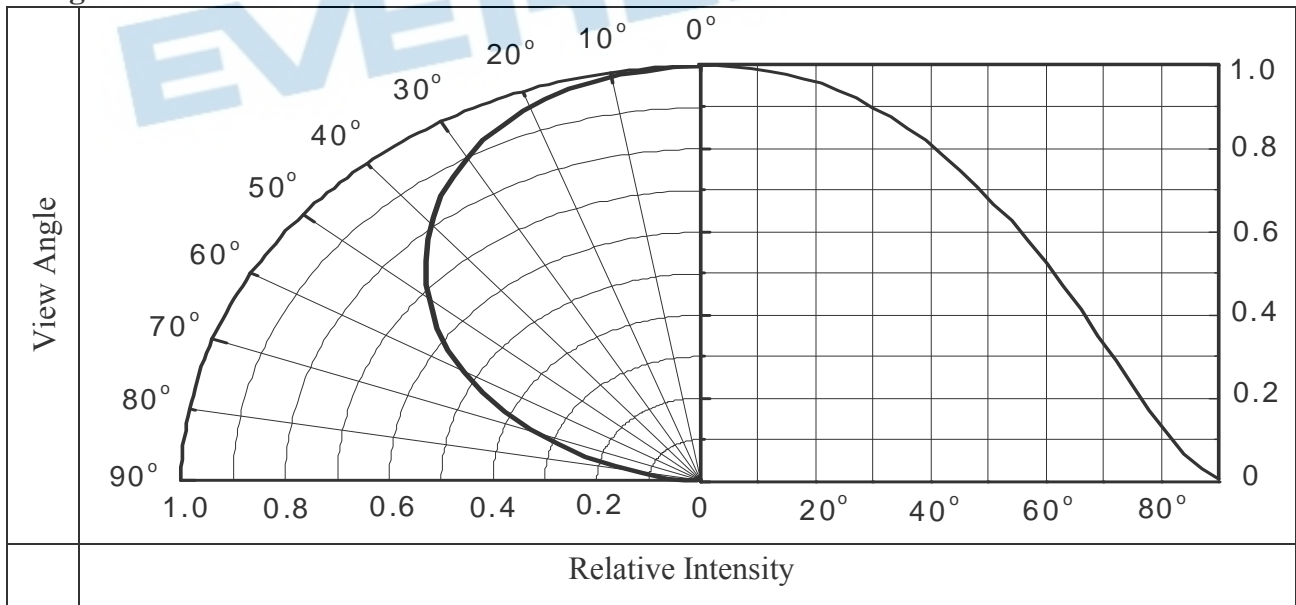

**Technical Data Sheet**  
**Top View LEDs**

**62-217D/Y7TC-AX2Z11Z150/2T**

**Typical Curve of Spectral Distribution**

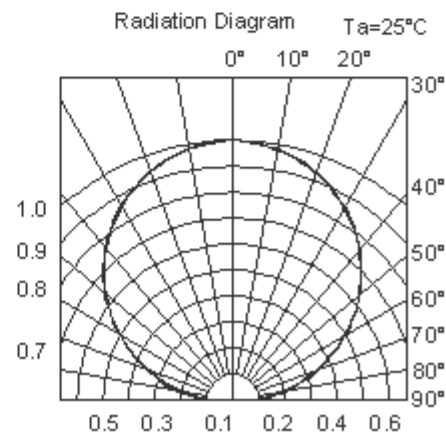
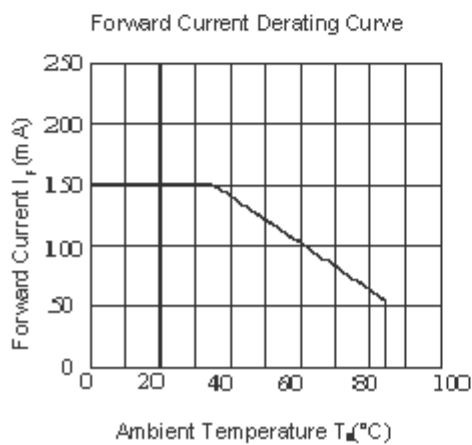
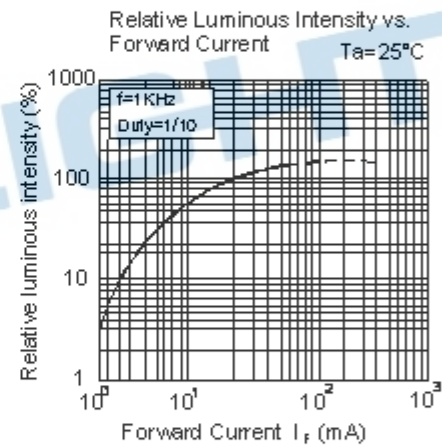
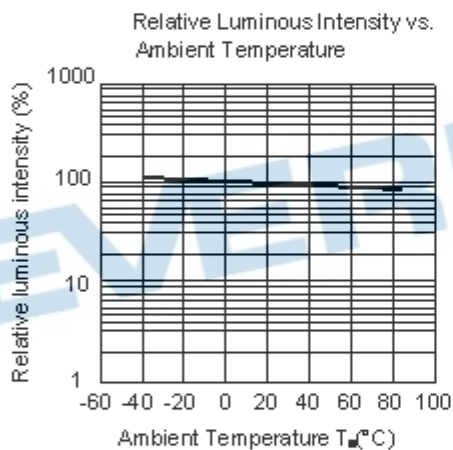
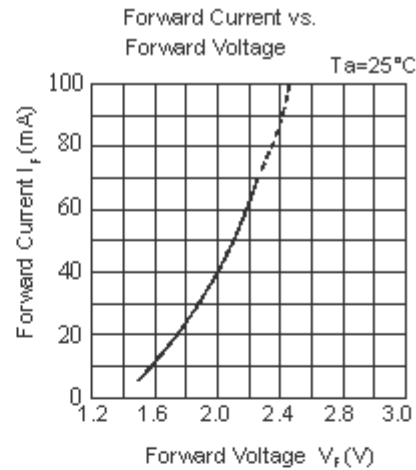
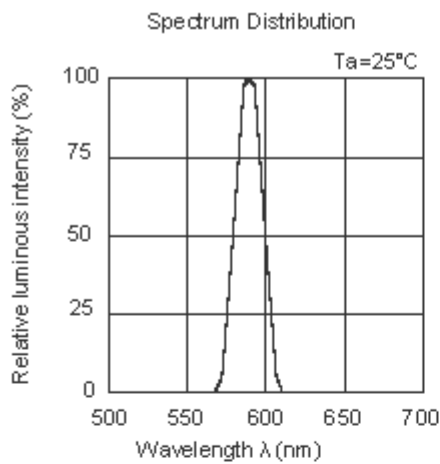

**Technical Data Sheet**  
**Top View LEDs**

**62-217D/Y7TC-AX2Z11Z150/2T**

**Label Explanation**

- CPN: Customer' s Product Number
- P/N: Product Number
- QTY: Packing Quantity
- CAT: Luminous Intensity Rank
- HUE: Dom. Wavelength Rank
- REF: Forward Voltage Rank
- LOT No: Lot Number



**Reel Dimensions**

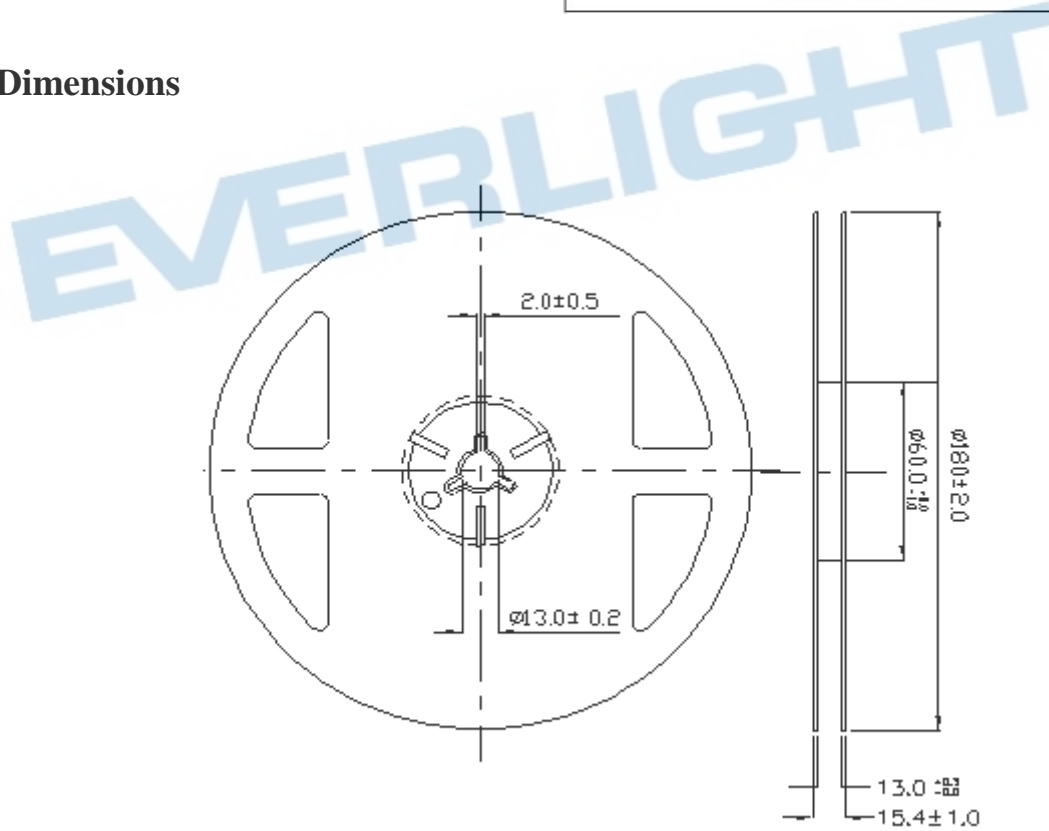

**Note:** The tolerance unless mentioned is  $\pm 0.1$ , unit = mm.



**Technical Data Sheet**  
**Top View LEDs**

**62-217D/Y7TC-AX2Z11Z150/2T**

**Carrier Tape Dimensions: Loaded Quantity 2000 pcs. Per Reel**

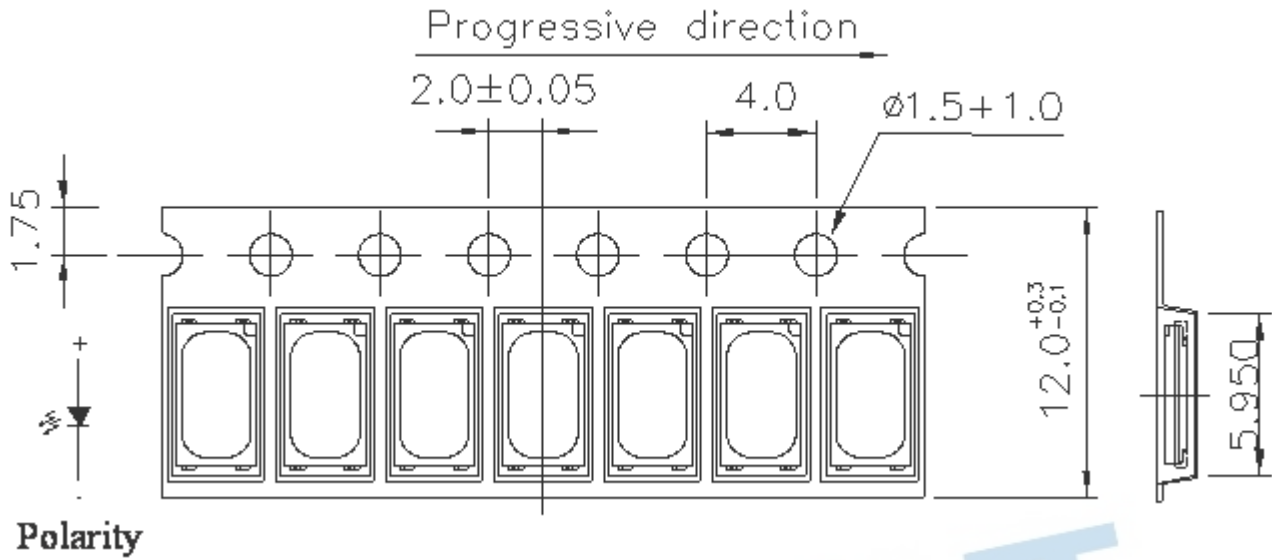

**Note:** 1. The tolerance unless mentioned is  $\pm 0.1$ , unit = mm.  
2. Minimum packing amount is 250/500/1000/2000 pcs per reel

**Moisture Resistant Packaging**

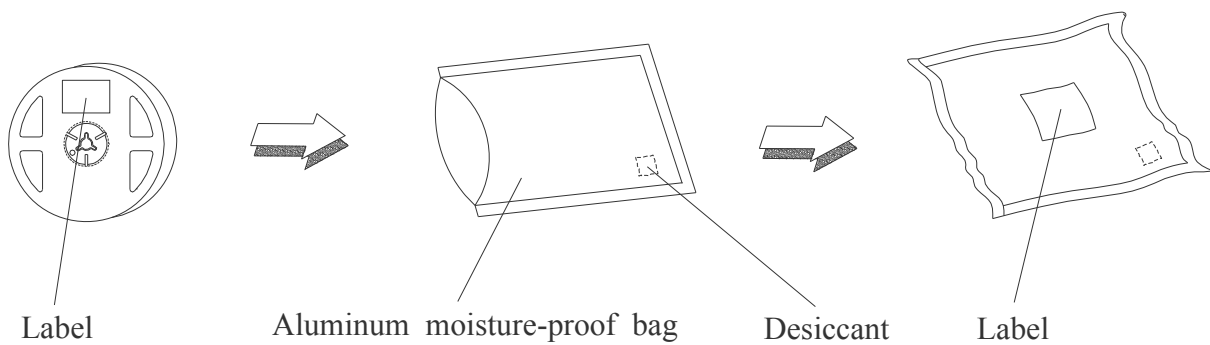

**Technical Data Sheet**  
**Top View LEDs****62-217D/Y7TC-AX2Z11Z150/2T****Reliability Test Items and Conditions**

The reliability of products shall be satisfied with items listed below.

Confidence level : 90%

LTPD : 10%

No.	Items	Test Condition	Test Hours/Cycles	Sample Size	Ac/Re
1	Reflow Soldering	Temp. : 260°C ±5°C Min. 10sec.	6 Min.	22 PCS.	0/1
2	Temperature Cycle	H : +100°C 15min ∫ 5 min L : -40°C 15min	300 Cycles	22 PCS.	0/1
3	Thermal Shock	H : +100°C 5min ∫ 10 sec L : -10°C 5min	300 Cycles	22 PCS.	0/1
4	High Temperature Storage	Temp. : 100°C	1000 Hrs.	22 PCS.	0/1
5	Low Temperature Storage	Temp. : -40°C	1000 Hrs.	22 PCS.	0/1
6	DC Operating Life	I <sub>F</sub> = 20 mA	1000 Hrs.	22 PCS.	0/1
7	High Temperature / High Humidity	85°C / 85%RH	1000 Hrs.	22 PCS.	0/1

**Technical Data Sheet**  
**Top View LEDs**

**62-217D/Y7TC-AX2Z11Z150/2T**

**Precautions for Use**

1. Over-current-proof

Customer must apply resistors for protection; otherwise slight voltage shift will cause big current change (Burn out will happen).

2. Storage

2.1 Don't open moisture proof bag before the products are ready to use.

2.2 Before opening the package: The LEDs should be kept at 30°C or less and 90%RH or less.

2.3 After opening the package: The LED's floor life is 72Hrs under 30°C or less and 60% RH or less. If unused LEDs remain, it should be stored in moisture proof packages.

2.4 If the moisture absorbent material (silica gel) has faded away or the LEDs have exceeded the storage time, baking treatment should be performed using the following conditions.

baking treatment: 60±5°C for 24 hours

3. Soldering Condition

3.1 Pb-free solder temperature profile:

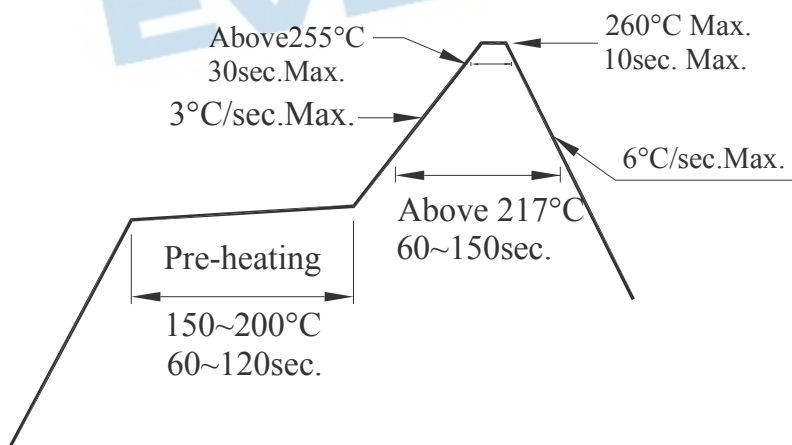

3.2 Reflow soldering should not be done more than two times.

3.3 When soldering, do not put stress on the LEDs during heating.

3.4 After soldering, do not warp the circuit board.

**Technical Data Sheet**  
**Top View LEDs**

**62-217D/Y7TC-AX2Z11Z150/2T**

4. Soldering Iron

Each terminal is to go to the tip of soldering iron temperature less than 350°C for 3 seconds within once in less than the soldering iron capacity 25W. Leave two seconds and more intervals, and do soldering of each terminal. Be careful because the damage of the product is often started at the time of the hand solder.

5. Repairing

Repair should not be done after the LEDs have been soldered. When repairing is unavoidable, a double-head soldering iron should be used (as below figure). It should be confirmed beforehand whether the characteristics of the LEDs will or will not be damaged by repairing.

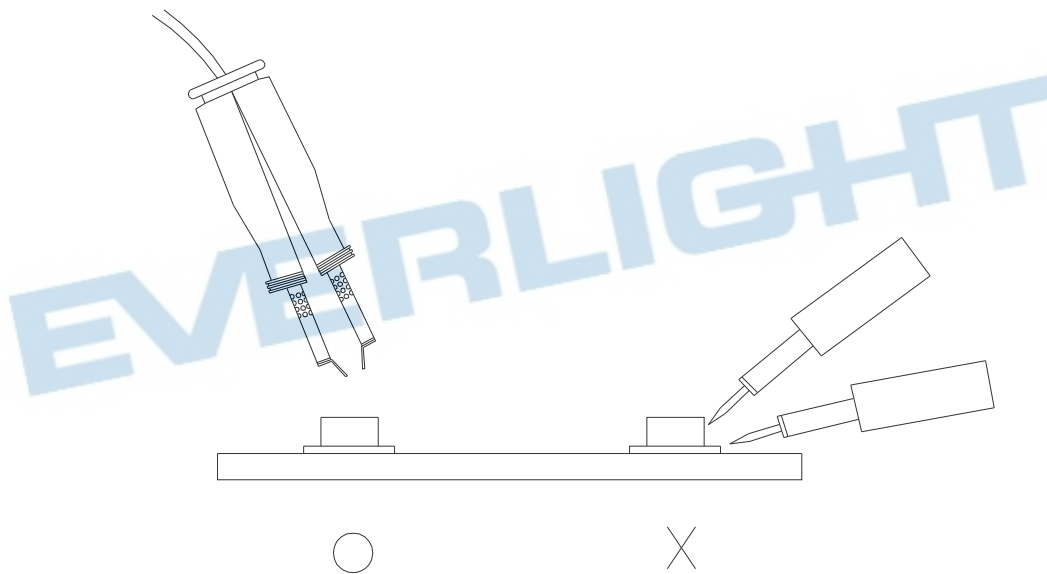

**EVERLIGHT ELECTRONICS CO., LTD.**  
 Office: No 25, Lane 76, Sec 3, Chung Yang Rd,  
 Tucheng, Taipei 236, Taiwan, R.O.C

Tel: 886-2-2267-2000, 2267-9936  
 Fax: 886-2267-6244, 2267-6189, 2267-6306  
<http://www.everlight.com>