

## EL Mini TOP VIEW LED 65-11-C70201H-AM



### Features

- Package : Cool White LED with PLCC 2 package
- Emitted Color : Cool White
- Typ. Luminance Intensity : 1800 mcd @ 20mA
- Typ. Luminous Flux : 4.5 lm @ 20mA
- Viewing angle : 120°
- ESD; up to 8KV
- MSL : 2a
- Preconditioning : According to JEDEC J-STD 020D Level 2a
- Qualifications; According to AEC-Q101
- Compliance with RoHS and REACH
- Au Plating L/F

### Applications

- Automotive Interior Lighting , Dashboard, Switch, Reading lamp, Audio and Car Infotainment....etc
- Backlight: LCD, switches, symbol, mobile phone and illuminated advertising.
- Optical indicator.
- General applications.

## Contents

<b>Characteristics</b> .....	3
<b>Absolute Maximum Ratings</b> .....	4
<b>Characteristics Graph</b> .....	5
<b>Binning Information</b> .....	9
<b>Part Number</b> .....	14
<b>Ordering Information</b> .....	15
<b>Mechanical Dimension</b> .....	16
<b>Recommended Soldering Pad</b> .....	17
<b>Reflow Soldering Profile</b> .....	17
<b>Packaging Information</b> .....	18
<b>Precaution for Use</b> .....	20

# 1. Characteristics

Parameter		Symbol	Min.	Typ.	Max.	Unit	Condition
Forward Current	Cool White	$I_F$	2	20	30	mA	---
Luminous Intensity	Cool White	$\Phi_v$	1120	1800	2800	mcd	$I_F=20\text{mA}$
Forward Voltage	Cool White	$V_F$	2.75	3.1	3.75	V	$I_F=20\text{mA}$
Viewing Angle	Cool White	$\phi$	---	120	---	deg	$I_F=20\text{mA}$
Color	Cool White	CIE x	---	0.3	---	---	$I_F=20\text{mA}$
Color	Cool White	CIE y	---	0.3	---	---	$I_F=20\text{mA}$
Thermal Resistance (Junction to Solder)	Real	$R_{th\ JS\ real}$	---	120	---	K/W	$I_F=20\text{mA}$
	Electrical	$R_{th\ JS\ el}$	---	95	---		

## Notes:

1. Luminous Intensity measurement tolerance:  $\pm 8\%$ .
2. The data of Luminous Intensity measured at thermal pad=25°C.
3. Typical luminous Intensity or light output performance is operated within the condition guided by this datasheet.
4. Forward voltage measurement tolerance:  $\pm 0.1\text{V}$ .
5. The  $V_F$  range shown in the table above indicates 99% output.
6. Tolerance of Chromaticity Coordinates x,y:  $\pm 0.005$ .

## 2. Absolute Maximum Ratings

Parameter	Symbol	Ratings	Unit
Power Dissipation	$P_d$	115	mW
Forward Current	$I_F$	2~30	mA
Reverse Voltage	$V_R$	Not designed for reverse operation	V
Junction Temperature	$T_J$	125	°C
Operating Temperature	$T_{opr}$	-40 ~ +110	°C
Storage Temperature	$T_{stg}$	-40 ~ +110	°C
ESD Sensitivity (R=1.5kΩ, C= 100pF)	$ESD_{HBM}$	8K	V
Soldering Temperature	Reflow	260°C for 30sec	°C

### 3.Characteristics Graph

**Wavelength Characteristics Relative Spectral Distribution**  
@ Ts = 25°C, If=20mA, RH=30%

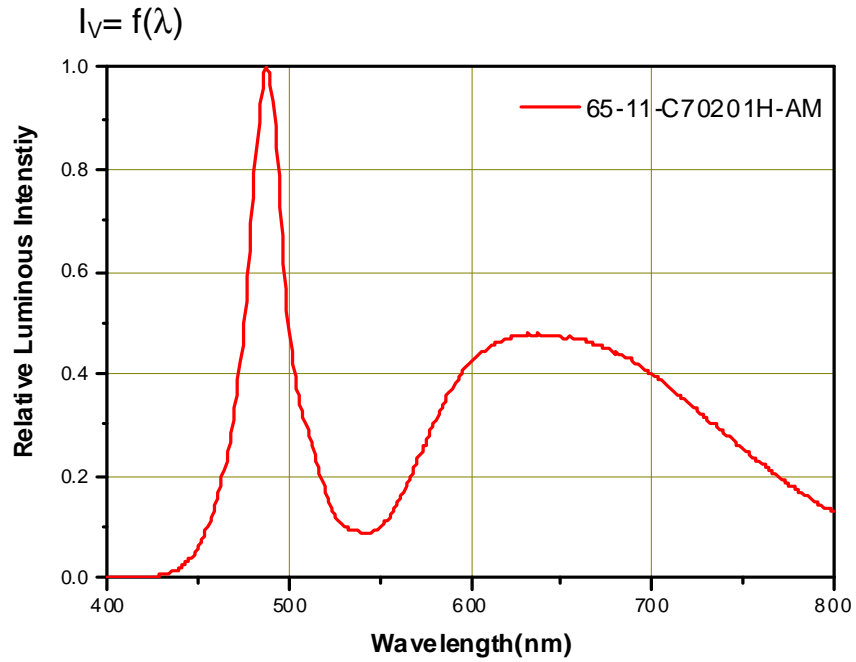

**Typical Diagram Characteristics of Radiation**

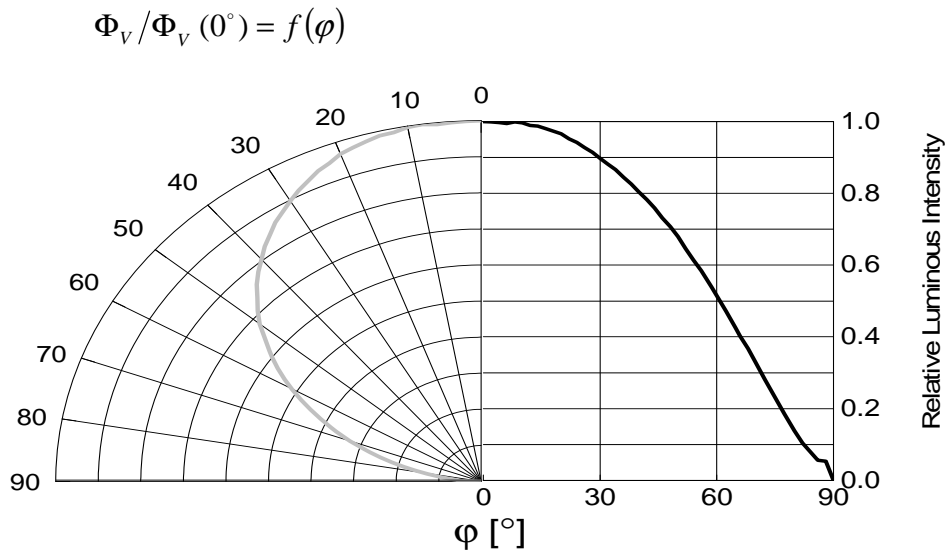

**Notes:**

1.  $\varphi$  is the off axis angle from lamp centerline where the luminous intensity is 1/2 of the peak value.

### Forward Current vs. Forward Voltage

@ Ts = 25°C

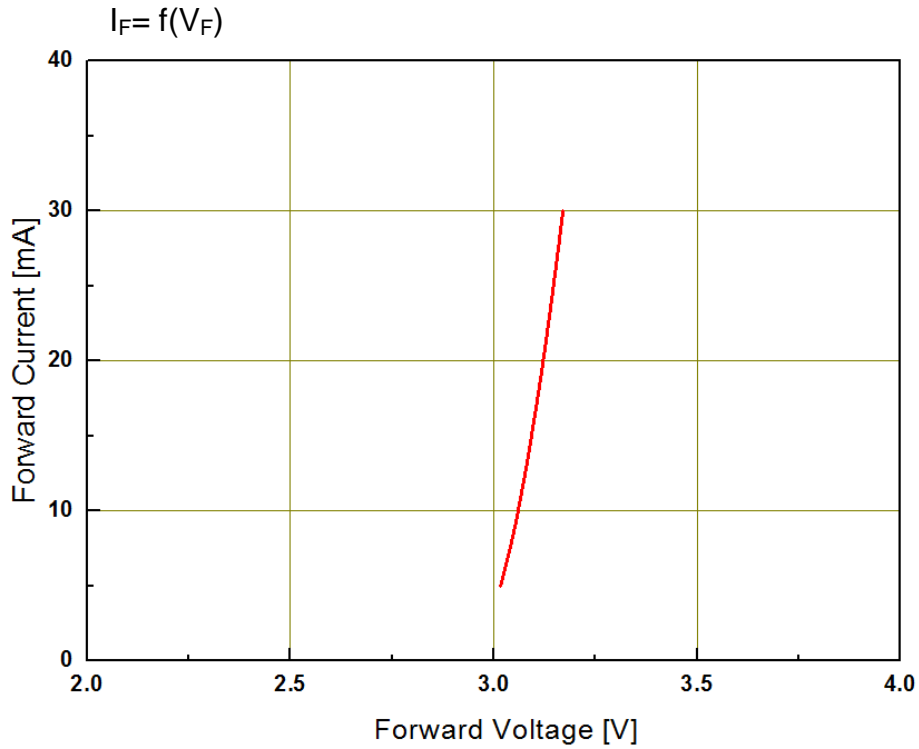

### Luminous vs. Forward Current

@ Ts = 25°C

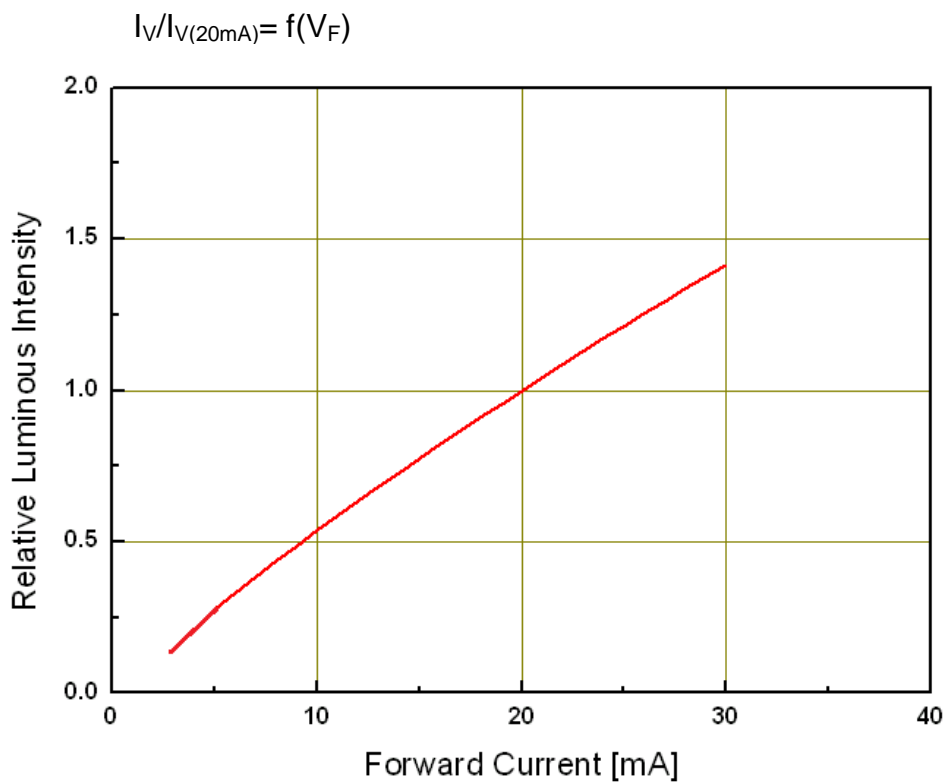

### Chromaticity Coordinates Shift vs. Forward Current

@  $T_s = 25^\circ\text{C}$

$$\Delta\text{CIE } x, \Delta\text{CIE } y = f(I_F)$$

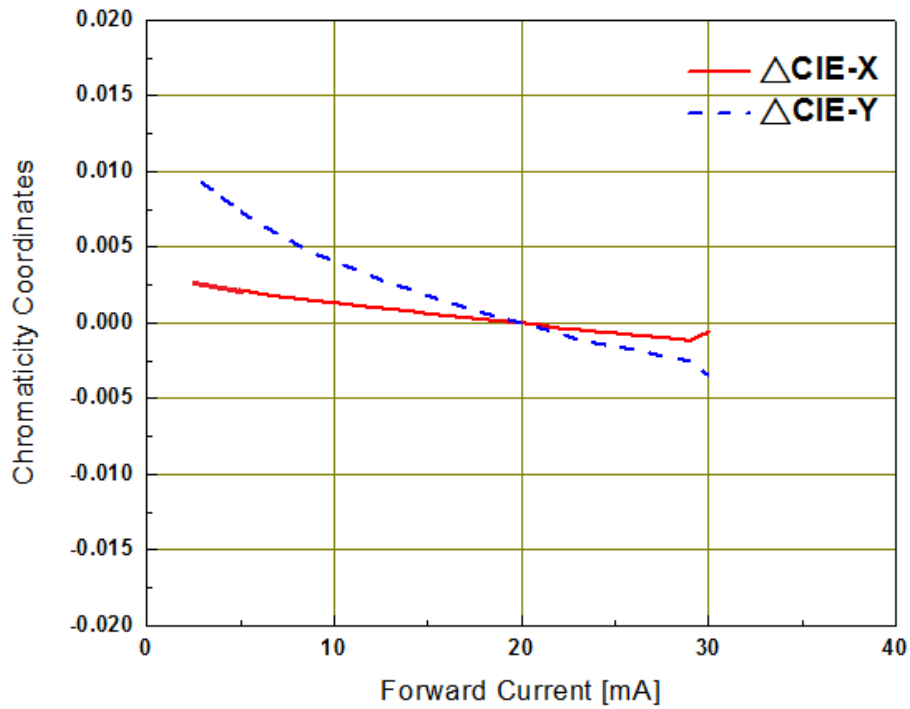

### Relative Forward Voltage vs. Junction Temperature

@  $I_F = 20\text{mA}$

$$V_F - V_F(T_J, 25^\circ\text{C}) = f(T_J)$$

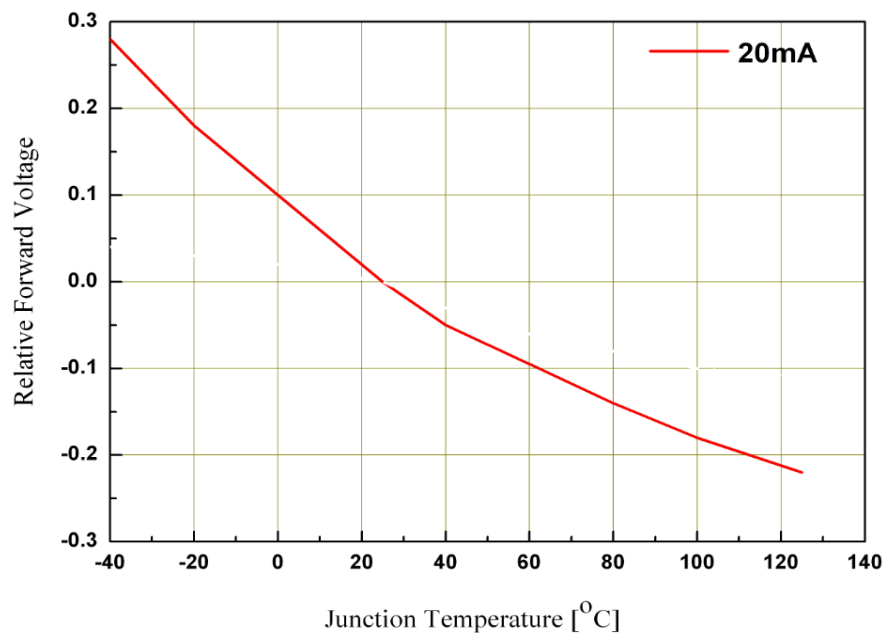

### Relative Luminous Intensity vs. Junction Temperature

@  $I_F=20\text{mA}$

$$I_V/I_V(T_J 25^\circ\text{C}) = f(T_J)$$

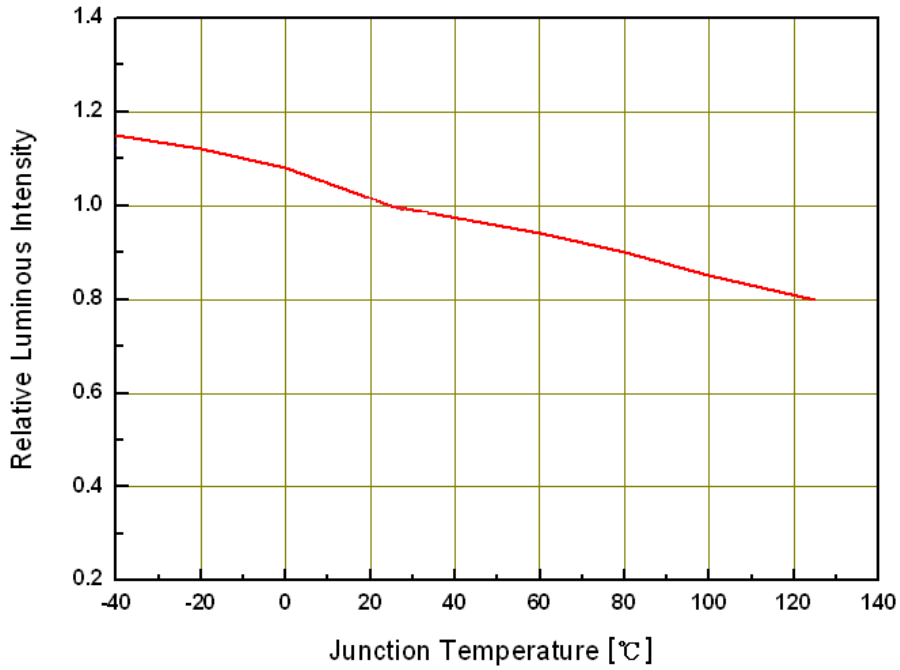

### Forward Current Derating Curve

$$I_F = f(T_S)$$

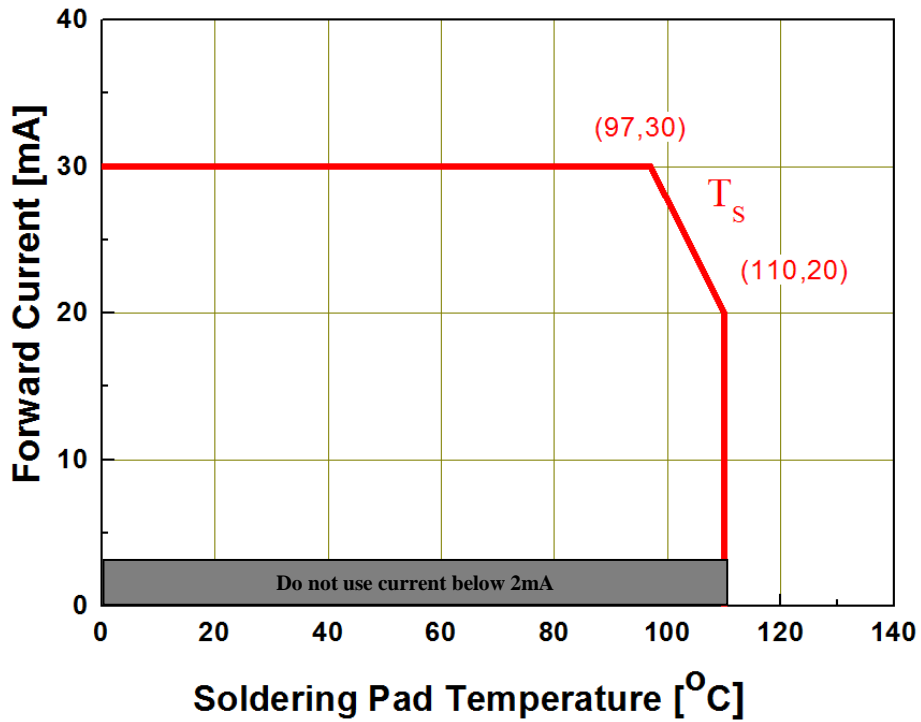



## 4. Binning Information

### Luminous Intensity Bins

Group Bin	Minimum Luminous Intensity (mcd)	Maximum Luminous Intensity (mcd)
L1	11.2	14
L2	14	18
M1	18	22.4
M2	22.4	28
N1	28	35.5
N2	35.5	45
P1	45	56
P2	56	71
Q1	71	90
Q2	90	112
R1	112	140
R2	140	180
S1	180	224
S2	224	280
T1	280	355
T2	355	450
U1	450	560
U2	560	710
V1	710	900
V2	900	1120
AA	1120	1400
AB	1400	1800
BA	1800	2240
BB	2240	2800
CA	2800	3550
CB	3550	4500
DA	4500	5600
DB	5600	7100
EA	7100	9000
EB	9000	11200
FA	11200	14000
FB	14000	18000
GA	18000	22400

**Notes:**

1. Luminous flux measurement tolerance:  $\pm 8\%$ .
2. Highlighted Black Box is available bins.

### Cool White Color Bin Structure

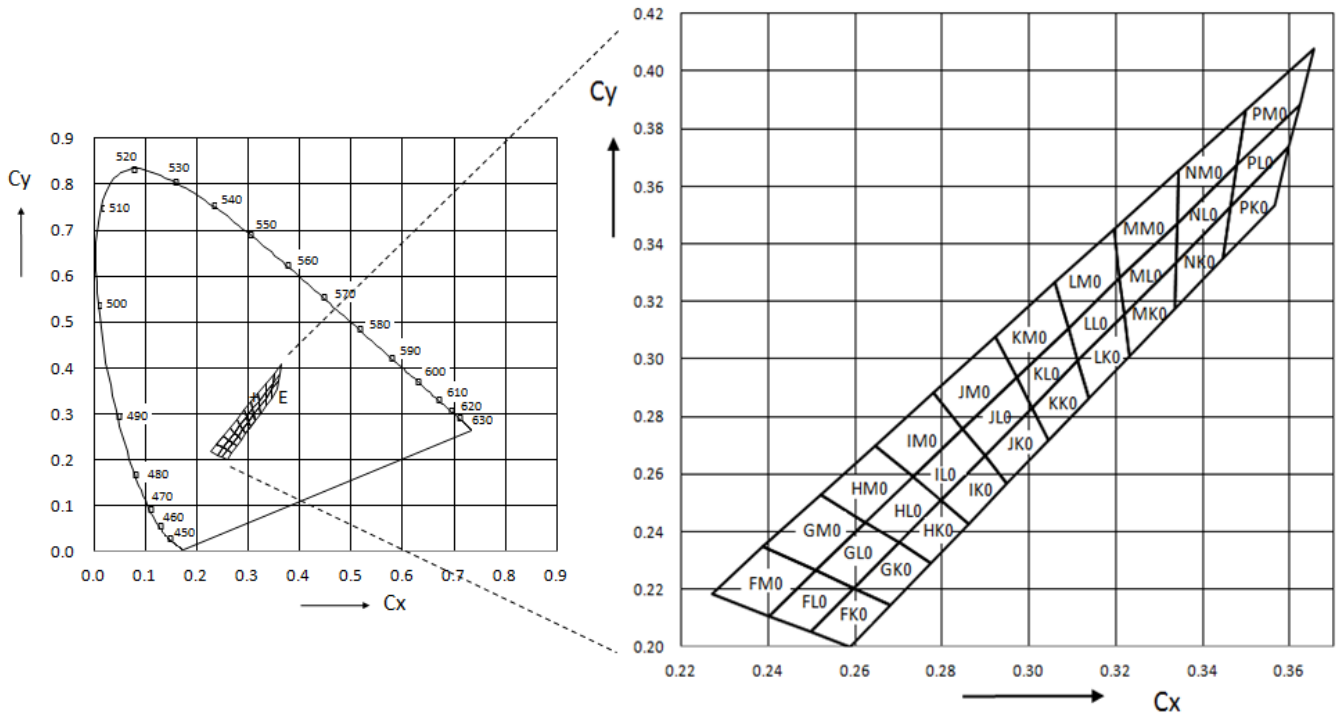

### Cool White Color Bin Coordinates

Bin Code	CIE_x	CIE_y	Bin Code	CIE_x	CIE_y
FK0	0.2589	0.2000	NK0	0.3339	0.3336
	0.2498	0.2053		0.3335	0.3172
	0.2597	0.2204		0.3447	0.3347
	0.2682	0.2146		0.3465	0.3530
GK0	0.2682	0.2146	PK0	0.3465	0.3530
	0.2597	0.2204		0.3447	0.3347
	0.2700	0.2361		0.3567	0.3535
	0.2775	0.2292		0.3599	0.3735
HK0	0.2775	0.2292	FL0	0.2498	0.2053
	0.2700	0.2361		0.2402	0.2108
	0.2797	0.2509		0.2509	0.2264
	0.2861	0.2427		0.2597	0.2204
IK0	0.2861	0.2427	GL0	0.2597	0.2204
	0.2797	0.2509		0.2509	0.2264
	0.2898	0.2664		0.2624	0.2431
	0.2950	0.2568		0.2700	0.2361
JK0	0.2950	0.2568	HL0	0.2700	0.2361
	0.2898	0.2664		0.2624	0.2431
	0.3007	0.2830		0.2733	0.2590
	0.3045	0.2717		0.2797	0.2509
KK0	0.3045	0.2717	IL0	0.2797	0.2509
	0.3007	0.2830		0.2733	0.2590
	0.3113	0.2992		0.2848	0.2757
	0.3138	0.2862		0.2898	0.2664
LK0	0.3138	0.2862	JL0	0.2898	0.2664
	0.3113	0.2992		0.2848	0.2757
	0.3219	0.3154		0.2971	0.2935
	0.3231	0.3008		0.3007	0.2830
MK0	0.3339	0.3336	KL0	0.3007	0.2830
	0.3219	0.3154		0.2971	0.2935
	0.3231	0.3008		0.3090	0.3108
	0.3335	0.3172		0.3113	0.2992

**Cool White Color Bin Coordinates**

Bin Code	CIE_x	CIE_y	Bin Code	CIE_x	CIE_y
LL0	0.3113	0.2992	IM0	0.2733	0.2590
	0.3090	0.3108		0.2646	0.2700
	0.3209	0.3281		0.2780	0.2883
	0.3219	0.3154		0.2848	0.2757
ML0	0.3341	0.3472	JM0	0.2848	0.2757
	0.3209	0.3281		0.2780	0.2883
	0.3219	0.3154		0.2922	0.3077
	0.3339	0.3336		0.2971	0.2935
NL0	0.3341	0.3472	KM0	0.2971	0.2935
	0.3339	0.3336		0.2922	0.3077
	0.3465	0.3530		0.3060	0.3266
	0.3479	0.3673		0.3090	0.3108
PL0	0.3479	0.3673	LM0	0.3090	0.3108
	0.3465	0.3530		0.3060	0.3266
	0.3599	0.3735		0.3196	0.3451
	0.3623	0.3882		0.3209	0.3281
FM0	0.2388	0.2348	MM0	0.3345	0.3654
	0.2269	0.2185		0.3196	0.3451
	0.2402	0.2108		0.3209	0.3281
	0.2509	0.2264		0.3341	0.3472
GM0	0.2509	0.2264	NM0	0.3345	0.3654
	0.2388	0.2348		0.3341	0.3472
	0.2520	0.2527		0.3479	0.3673
	0.2624	0.2431		0.3498	0.3863
HM0	0.2624	0.2431	PM0	0.3498	0.3863
	0.2530	0.2527		0.3479	0.3673
	0.2646	0.2700		0.3623	0.3882
	0.2733	0.2590		0.3655	0.4079

## Forward Voltage Bins

Bin code	Forward Voltage [V]
10	1.00
12	1.25
15	1.50
17	1.75
20	2.00
22	2.25
25	2.50
27	2.75
30	3.00
32	3.25
35	3.50
37	3.75
40	4.00
42	4.25
45	4.50
47	4.75
50	5.00
52	5.25
55	5.50
57	5.75
60	6.00
62	6.25
65	6.50
67	6.75
70	7.00

**Notes:**

1. Forward voltage measurement tolerance:  $\pm 0.05V$ .
2. Forward voltage bins are defined at  $I_F = 20mA$  operation.

## 5.Part Number

### 65-11-C70201H-AM

Part number is designated with below details.

65-11 = Product family name.

C = Color <sup>[1]</sup>

7 = CRI (0=N/A; >70%=7; >80%=8; >90%=9)

020 = Test current [mA]

1 = Lead Frame Type (0=Ag; 1=Au)

H = Brightness Level (H=High; L=Low)

AM = Automotive application

Note

<sup>[1]</sup> Color :

Symbol	Description
C	Cool White
N	Neutral White
W	Warm White
PA	Phosphor Converted Amber
PR	Phosphor Converted Red
UB	Blue
IB	Ice Blue
SB	Sky Blue
UG	Green
UY	Yellow
UA	Amber
UR	Red
SR	Super Red
RGB	RGB-Color

## 6. Ordering Information

**65-11- C70201H-ABCDEFGHIJKLMNO-PQ-AM**

Part Number of the 65-11	Order Code
65-11-C70201H-AM	65-11-C70201H-PM0FK0ABBB2737-2T-AM

Order code contains information with below details :

ABCDEF = min/max wavelength or CCT

GHJK = min./max. luminous flux in [lm] or luminous intensity in [mcd]

LMNO = min./max. forward voltage

PQ = internal code

AM = Automotive Application

## 7. Mechanical Dimension

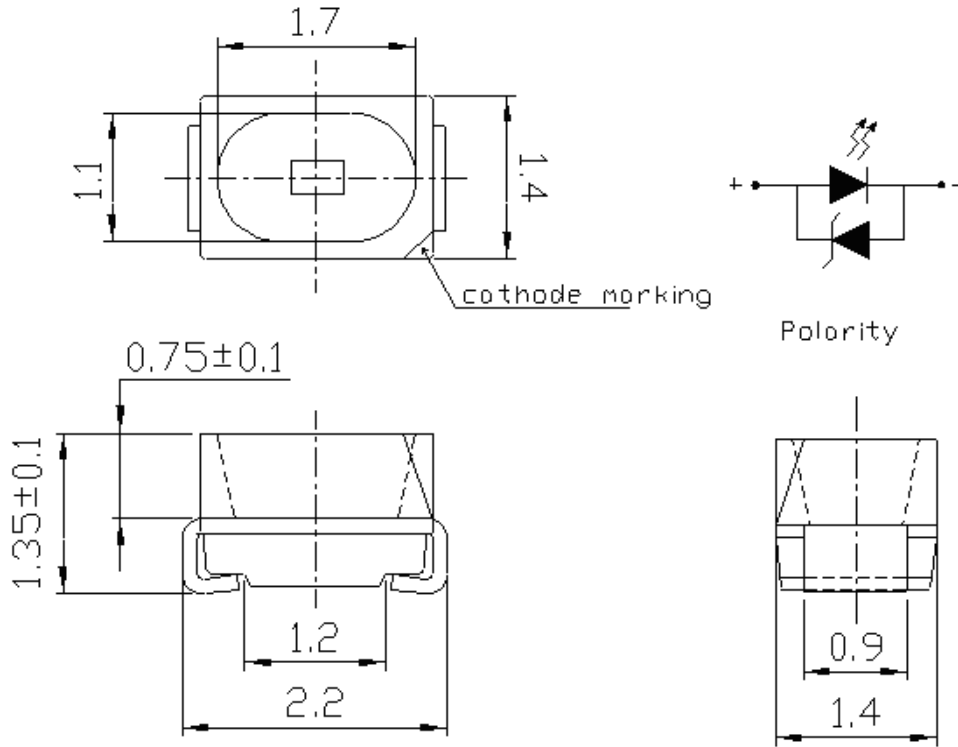

### Notes:

1. Dimensions are in millimeters.
2. Tolerances unless mentioned are ± 0.1mm.



## 8. Recommended Soldering Pad

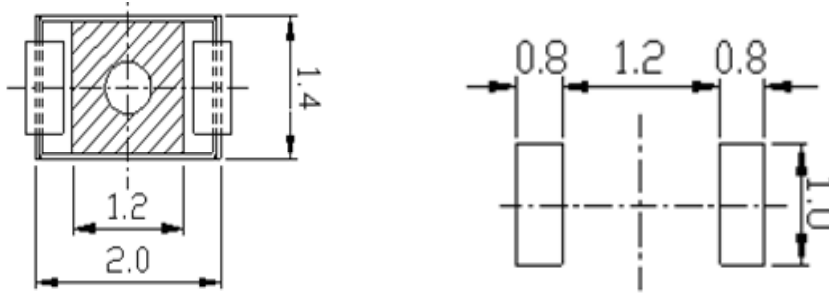

## 9. Reflow Soldering Profile

Soldering Condition (Reference: IPC/JEDEC J-STD-020D)

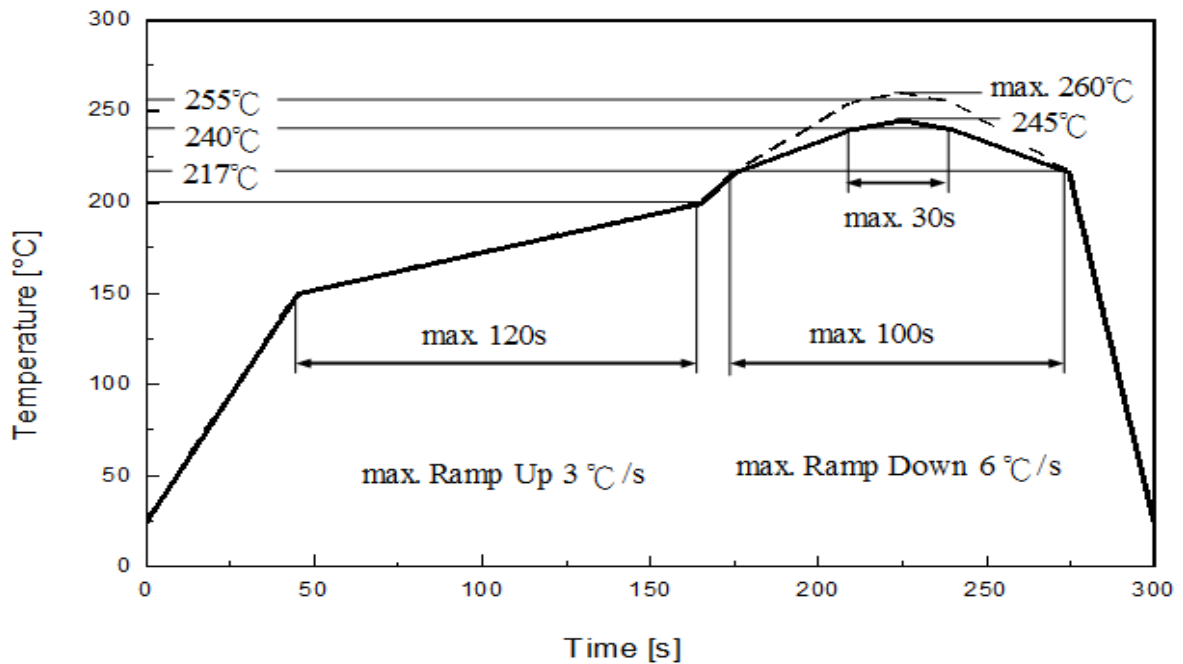

Profile Feature	Pb-Free Assembly	Unit
	Recommendation	
Ramp-up rate to preheat 25 °C to 150 °C	3	°C /sec
Time of soaking zone 150 °C to 200 °C	120	sec
Ramp-up rate to peak	3	°C /sec
Liquidus temperature	217	°C
Time above liquidus temperature	100	sec
Peak temperature (max.)	260	°C
Time within 5°C of the specified peak temperature	30	sec
Ramp-down Rate (max.)	6	°C /sec

## 10. Packaging Information

### ● Product Labeling

RoHS **(Pb) EVERLIGHT** 5

CPN: XXXXXXXXXXXXXXXXXXXX  
 XXXXXXXXXXXX-XXXXXXXXXX-XXXXXXXXXX-XXXXXX  
 P/N: XXXXXXXXX  
 XXXXXXXXXXXX-XXXXXXXXXX-XXXXXXXXXX-XXXXXX  
 LOT NO: Y150716XXX-XXXXXXXXXX-XXXXXXXXXX  
 QTY: 0123456789 HUE: XXXXXXXXXXXX  
 CAT: XXXXXXXXXX REF: XXXXXXXXXX  
 REFERENCE: BTPYMMDDXXXXX  
 MSL-X MADE IN XXXXXX



- CPN : Customer's Product Number
- P/N : Everlight Part Number
- QTY : Packing Quantity
- CAT : Luminous Flux (Brightness) Bin
- HUE : Color Bin
- REF : Forward Voltage Bin
- LOT No : Lot Number

### ● Packing: Loaded Quantity 2000 pcs Per Reel

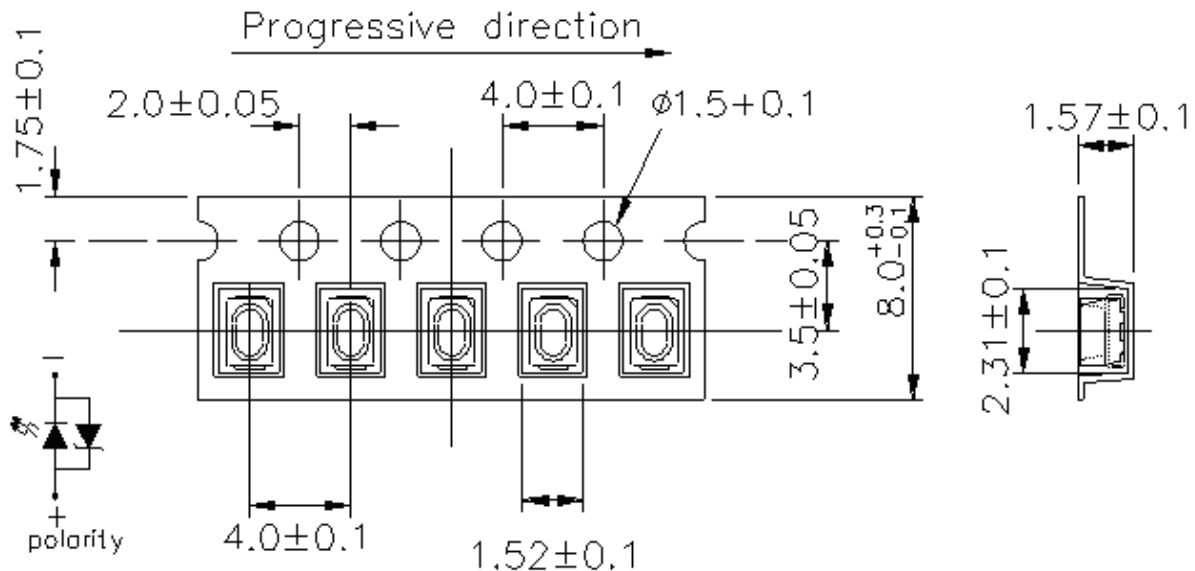

**Notes:**

1. Dimensions are in millimeters.
2. Tolerances for fixed dimensions are ±0.2mm.

● **Reel Dimensions**

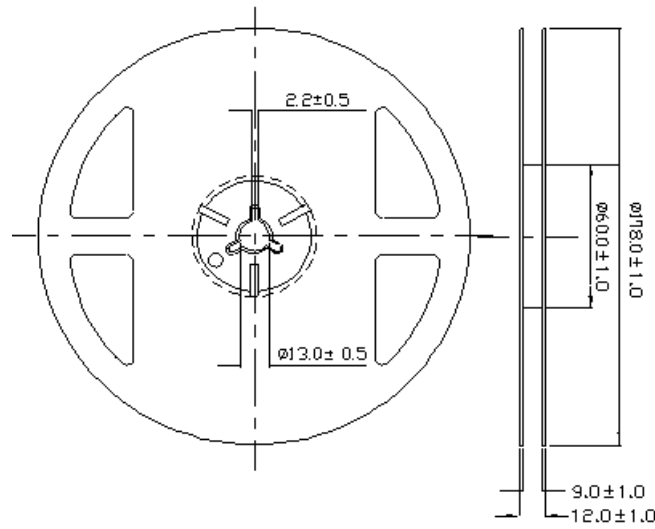

**Notes:**

1. Dimensions are in millimeters.
2. Tolerances unless mentioned are ±0.2mm.

● **Moisture Resistant Packing Process**

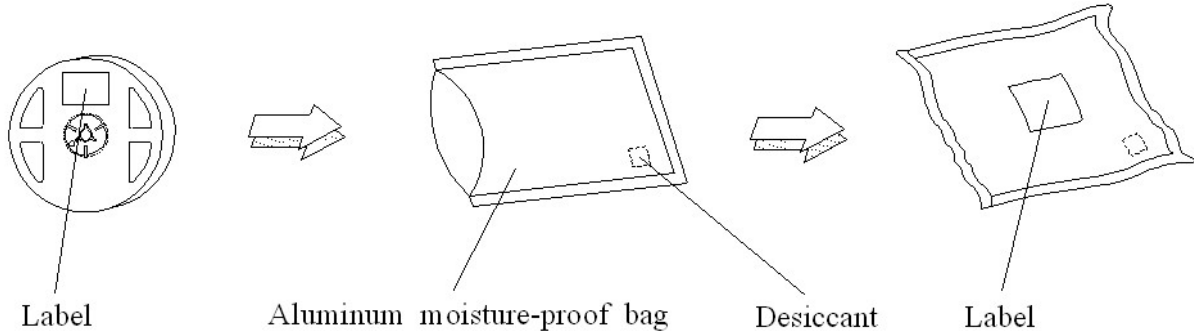

**Notes:**

1. Dimensions are in millimeters.
2. Tolerances unless mentioned are ±0.2mm.

## 11. Precaution for Use

### 1. Over-current-proof

Customer must apply resistors for protection; otherwise slight voltage shift will cause big current change (burn out will happen).

### 2. Assemblies

Do not stack assemblies containing LEDs to prevent damage to the optical surface of LEDs. Forces applied to the optical surface may result in the surface being damaged.

### 3. Soldering Condition

3.1 When soldering, do not put stress on the LEDs during heating.

3.2 After soldering, do not warp the circuit board.

### 4. Soldering Iron

Each terminal is to go to the tip of soldering iron temperature less than 350°C for 3 seconds within once in less than the soldering iron capacity 25W. Leave two seconds and more intervals, and do soldering of each terminal. Be careful because the damage of the product is often started at the time of the hand solder.

### 5. Repairing

Repair should not be done after the LEDs have been soldered. When repairing is unavoidable, a double-head soldering iron should be used (as below figure). It should be confirmed beforehand whether the characteristics of the LEDs will or will not be damaged by repairing.

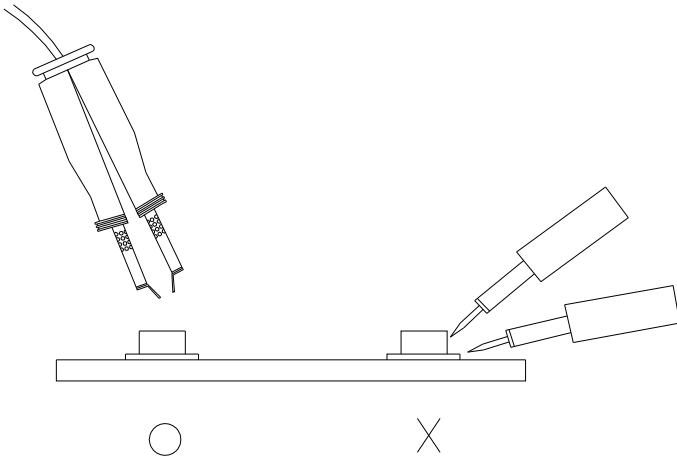

## Revision History

Current version: Sep.12.2016

Issue No:

Version: 1.0

Created by: Una lin

Rev.	Subjects (major change in previous version)	Modified date
1.0	Standard data sheet	2016/09/12