

EL Power TOP VIEW LED 67-41-C70301H-AM



Features

- Package : Cool White LED with PLCC 4 package
- Emitted Color : Cool White
- Typ. Luminance Intensity : 2,800 mcd @ 30mA
- Typ. Luminous Flux : 8.5 lm @ 30mA
- Viewing angle : 120°
- ESD; up to 8KV
- Qualifications; According to AEC-Q101
- Compliance with RoHS and REACH
- Au Plating L/F

Applications

- Automotive Interior Lighting, Dashboard, Switch, Reading lamp, Audio and Car Infotainment....etc
- Backlight: LCD, switches, symbol, mobile phone and illuminated advertising.
- Optical indicator.
- General applications.

Contents

Characteristics	3
Absolute Maximum Ratings	4
Characteristics Graph	5
Binning Information	11
Part Number	16
Ordering Information	17
Reliability Test	18
Mechanical Dimension	19
Recommended Soldering Pad	20
Reflow Soldering Profile	20
Packaging Information	21
Precaution for Use	22

1. Characteristics

Parameter		Symbol	Min.	Typ.	Max.	Unit	Condition
Forward Current	Cool White	I_F	5	30	70	mA	---
Luminous Intensity	Cool White	Φ_v	2240	2800	4500	mcd	$I_F=30\text{mA}$
Forward Voltage	Cool White	V_F	2.75	3.1	3.75	V	$I_F=30\text{mA}$
Viewing Angle	Cool White	φ	---	120	---	deg	$I_F=30\text{mA}$
Color	Cool White	CIE x	---	0.32	---	---	$I_F=30\text{mA}$
Color	Cool White	CIE y	---	0.33	---	---	$I_F=30\text{mA}$
Thermal Resistance (Junction to Solder)	Real	$R_{th JS real}$	---	430	---	K/W	$I_F=30\text{mA}$
	Electrical	$R_{th JS el}$	---	250	---		

Notes:

1. Luminous Intensity measurement tolerance: $\pm 8\%$.
2. The data of Luminous Intensity measured at thermal pad=25°C.
3. Typical luminous Intensity or light output performance is operated within the condition guided by this datasheet.
4. Forward voltage measurement tolerance: $\pm 0.05\text{V}$.
5. The V_F range shown in the table above indicates 99% output.
6. Tolerance of Chromaticity Coordinates x,y: ± 0.005 .

2. Absolute Maximum Ratings

Parameter	Symbol	Ratings	Unit
Power Dissipation	P_d	225	mW
Forward Current	I_F	5~70	mA
Reverse Voltage	V_R	Not designed for reverse operation	V
Junction Temperature	T_J	125	°C
Operating Temperature	T_{opr}	-40 ~ +110	°C
Storage Temperature	T_{stg}	-40 ~ +110	°C
ESD Sensitivity (R=1.5kΩ, C= 100pF)	ESD_{HBM}	8K	V
Soldering Temperature	Reflow	260°C for 30sec	°C

3. Characteristics Graph

Wavelength Characteristics Relative Spectral Distribution

@ Ts = 25°C, If=30mA, RH=30%

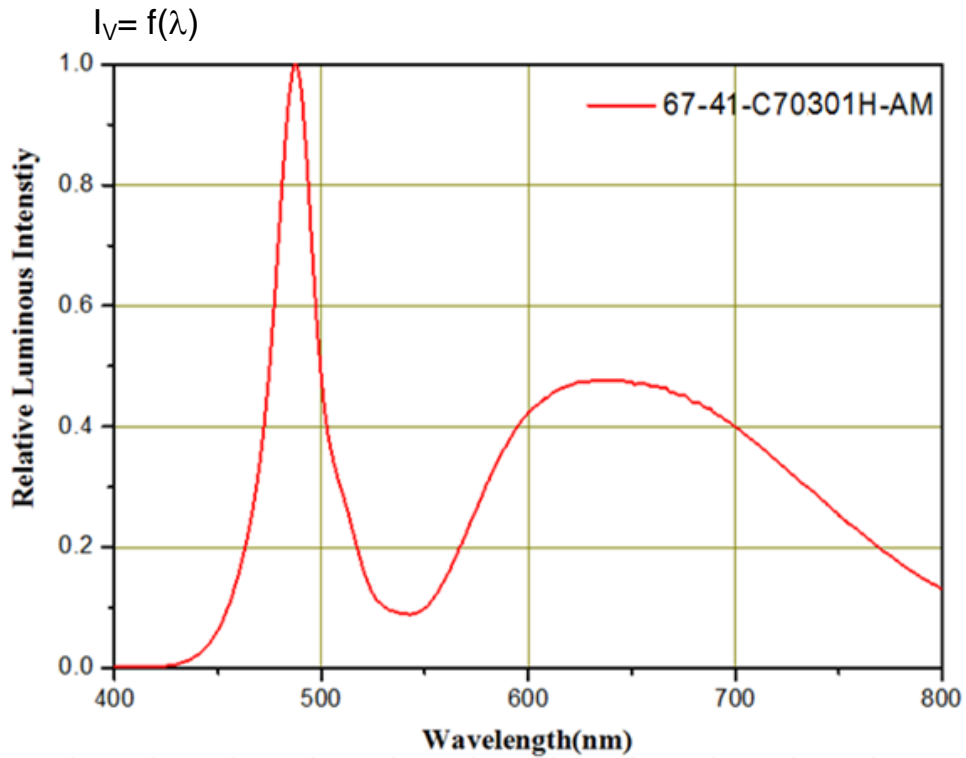

Typical Diagram Characteristics of Radiation

$\Phi_v / \Phi_v(0^\circ) = f(\varphi)$

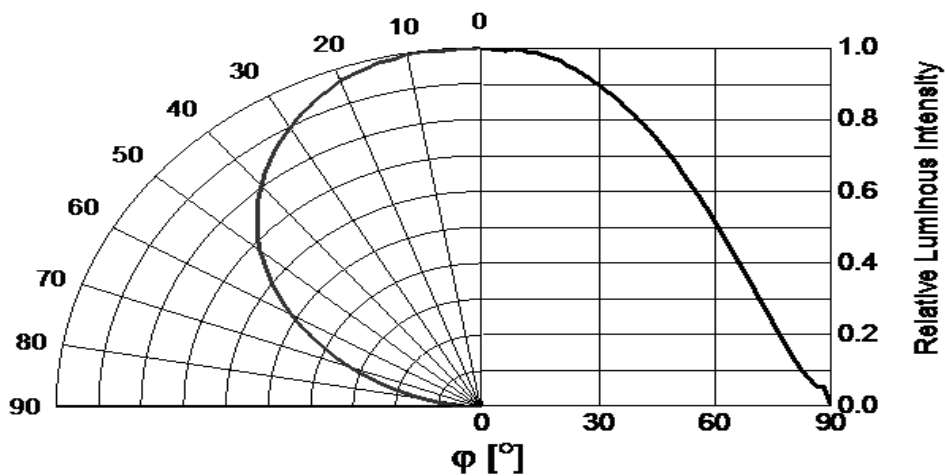

Notes:

1. φ is the off axis angle from lamp centerline where the luminous intensity is 1/2 of the peak value.

Forward Current vs. Forward Voltage

@ Ts = 25°C

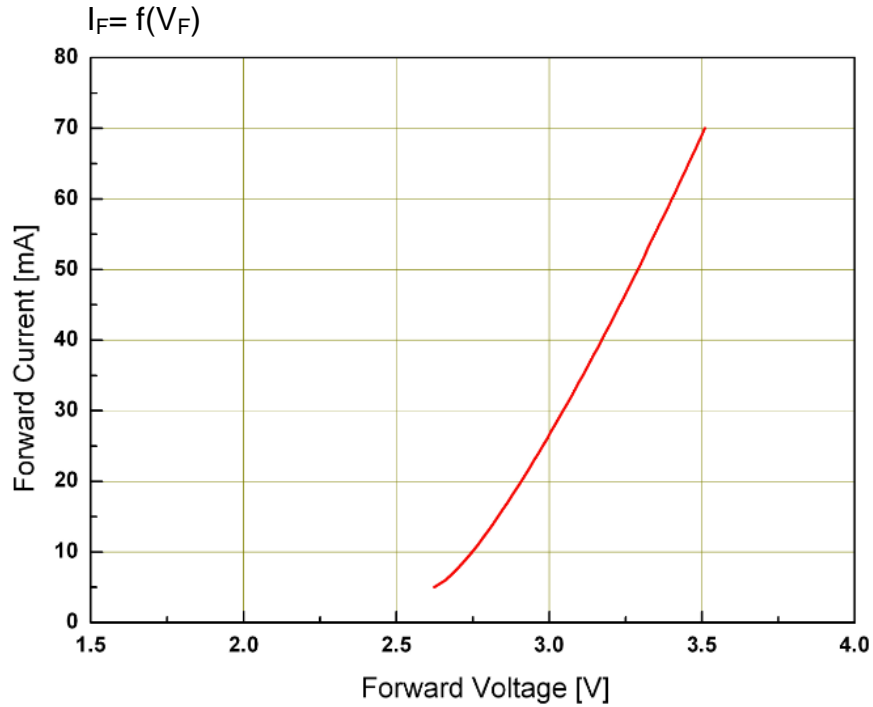

Luminous vs. Forward Current

@ Ts = 25°C

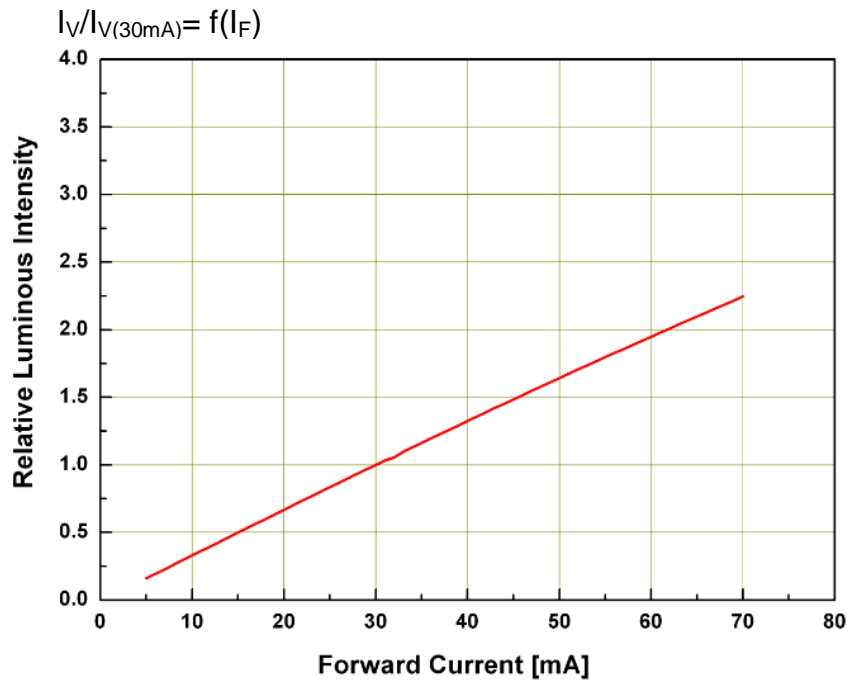

Chromaticity Coordinates Shift vs. Forward Current

@ $T_s = 25^\circ\text{C}$

$$\Delta \text{CIE } x, \Delta \text{CIE } y = f(I_F)$$

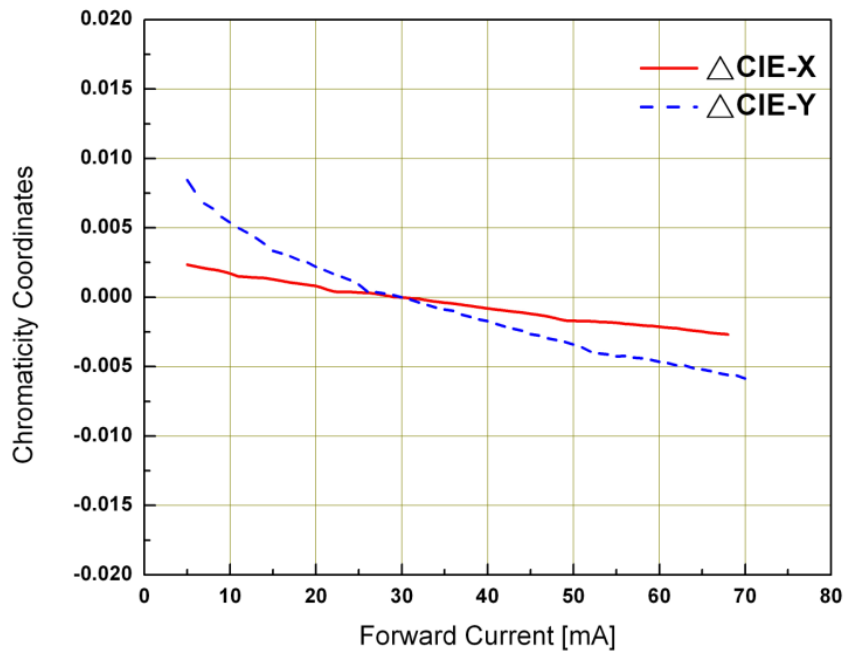

Relative Forward Voltage vs. Junction Temperature

@ $I_F = 30\text{mA}$

$$V_F - V_F(T_{J,25^\circ\text{C}}) = f(T_J)$$

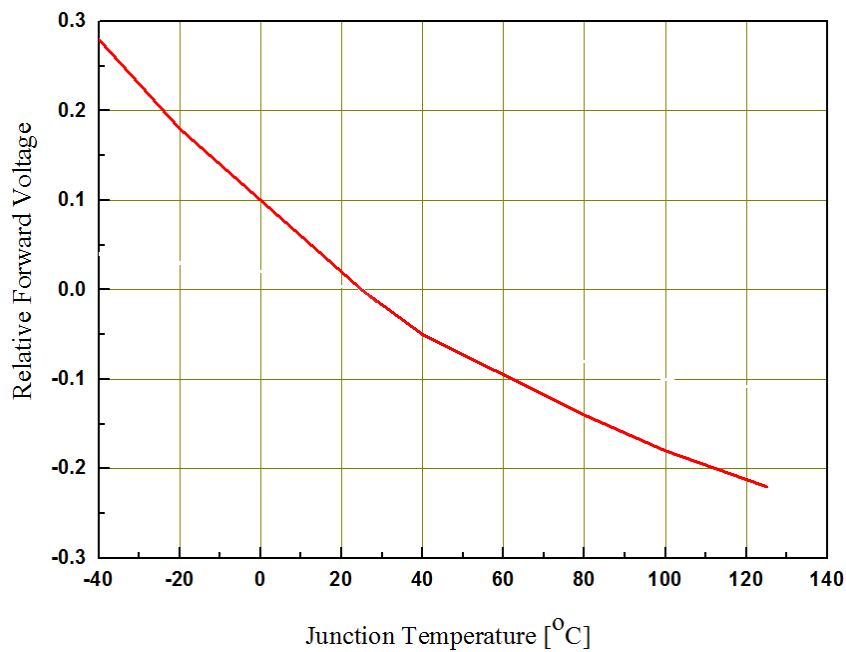

Relative Luminous Intensity vs. Junction Temperature

@ $I_F=30\text{mA}$

$$I_V/I_V(T_J 25^\circ\text{C}) = f(T_J)$$

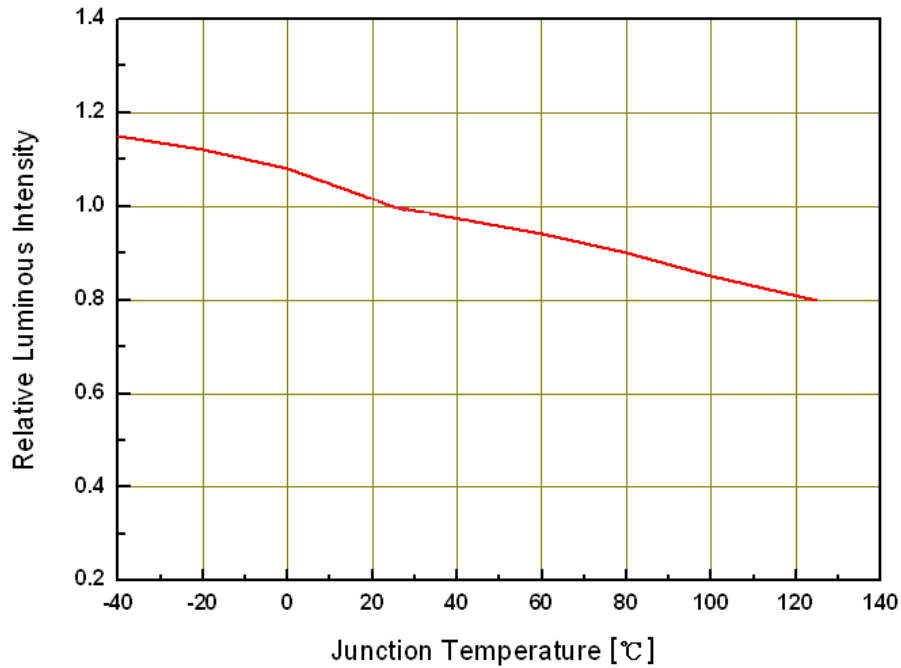

Forward Current Derating Curve

$$I_F = f(T_S)$$

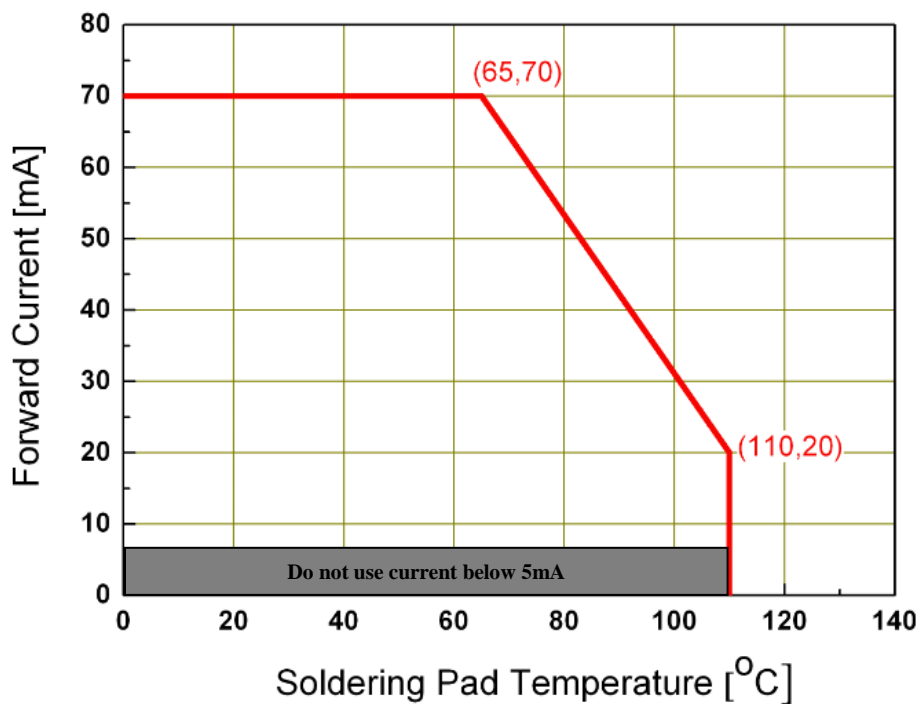

4. Binning Information

Luminous Intensity Bins

Group Bin	Minimum Luminous Intensity (mcd)	Maximum Luminous Intensity (mcd)
L1	11.2	14
L2	14	18
M1	18	22.4
M2	22.4	28
N1	28	35.5
N2	35.5	45
P1	45	56
P2	56	71
Q1	71	90
Q2	90	112
R1	112	140
R2	140	180
S1	180	224
S2	224	280
T1	280	355
T2	355	450
U1	450	560
U2	560	710
V1	710	900
V2	900	1120
AA	1120	1400
AB	1400	1800
BA	1800	2240
BB	2240	2800
CA	2800	3550
CB	3550	4500
DA	4500	5600
DB	5600	7100
EA	7100	9000
EB	9000	11200
FA	11200	14000
FB	14000	18000
GA	18000	22400

Notes:

1. Luminous flux measurement tolerance: $\pm 8\%$.
2. Highlighted Black Box is available bins.

White Color Bin Structure

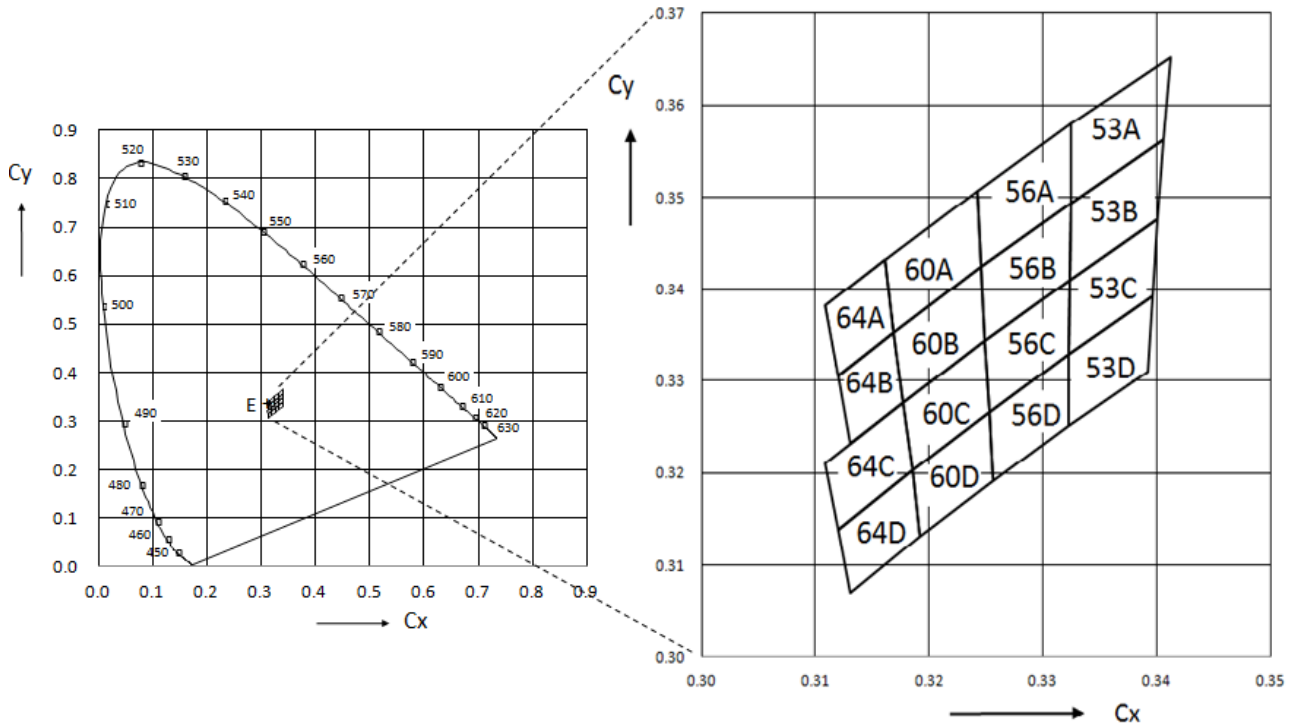

White Color Bin Coordinates

Bin	CIE x	CIE y
64A	0.3109	0.3382
	0.3161	0.3432
	0.3169	0.3353
	0.3120	0.3306
Reference Range: 6240~6530K		

Bin	CIE x	CIE y
64B	0.3120	0.3306
	0.3169	0.3353
	0.3177	0.3277
	0.3131	0.3232
Reference Range: 6240~6530K		

Bin	CIE x	CIE y
64C	0.3109	0.3211
	0.3177	0.3277
	0.3185	0.3203
	0.3120	0.3139
Reference Range: 6240~6680K		

Bin	CIE x	CIE y
64D	0.3120	0.3139
	0.3185	0.3203
	0.3192	0.3131
	0.3131	0.3070
Reference Range: 6240~6680K		

Bin	CIE x	CIE y
60A	0.3161	0.3432
	0.3242	0.3506
	0.3246	0.3424
	0.3169	0.3353
Reference Range: 5850~6240K		

Bin	CIE x	CIE y
60B	0.3169	0.3353
	0.3246	0.3424
	0.3249	0.3344
	0.3177	0.3277
Reference Range: 5850~6240K		

Bin	CIE x	CIE y
60C	0.3177	0.3277
	0.3249	0.3344
	0.3253	0.3266
	0.3185	0.3203
Reference Range: 5850~6240K		

Bin	CIE x	CIE y
60D	0.3185	0.3203
	0.3253	0.3266
	0.3256	0.3191
	0.3192	0.3131
Reference Range: 5850~6240K		

Bin	CIE x	CIE y
56A	0.3242	0.3506
	0.3325	0.3579
	0.3325	0.3493
	0.3246	0.3424
Reference Range: 5500~5850K		

Bin	CIE x	CIE y
56B	0.3246	0.3424
	0.3325	0.3493
	0.3324	0.3410
	0.3249	0.3344
Reference Range: 5500~5850K		

Bin	CIE x	CIE y
56C	0.3249	0.3344
	0.3324	0.3410
	0.3323	0.3329
	0.3253	0.3266
Reference Range: 5500~5850K		

Bin	CIE x	CIE y
56D	0.3253	0.3266
	0.3323	0.3329
	0.3323	0.3251
	0.3256	0.3191
Reference Range: 5500~5850K		

Bin	CIE x	CIE y
53A	0.3325	0.3579
	0.3412	0.3652
	0.3406	0.3562
	0.3325	0.3493
Reference Range: 5180~5500K		

Bin	CIE x	CIE y
53B	0.3325	0.3493
	0.3406	0.3562
	0.3401	0.3476
	0.3324	0.3410
Reference Range: 5180~5500K		

Bin	CIE x	CIE y
53C	0.3324	0.3410
	0.3401	0.3476
	0.3396	0.3392
	0.3323	0.3329
Reference Range: 5180~5500K		

Bin	CIE x	CIE y
53D	0.3323	0.3329
	0.3396	0.3392
	0.3392	0.3310
	0.3323	0.3251
Reference Range: 5180~5500K		

Forward Voltage Bins

Bin code	Forward Voltage [V]
10	1.00
12	1.25
15	1.50
17	1.75
20	2.00
22	2.25
25	2.50
27	2.75
30	3.00
32	3.25
35	3.50
37	3.75
40	4.00
42	4.25
45	4.50
47	4.75
50	5.00
52	5.25
55	5.50
57	5.75
60	6.00
62	6.25
65	6.50
67	6.75
70	7.00

Notes:

1. Forward voltage measurement tolerance: $\pm 0.05V$.
2. Forward voltage bins are defined at $I_F = 30mA$ operation.

5. Part Number

67-41-C70301H-AM

Part number is designated with below details.

67-41 = Product family name.

C = Color ^[1]

7 = CRI (0=N/A; >70%=7; >80%=8; >90%=9)

030 = Test current [mA]

1 = Lead Frame Type (0=Ag; 1=Au)

H = Brightness Level (H=High; L=Low)

AM = Automotive application

Note

^[1] Color :

Symbol	Description
C	Cool White
N	Neutral White
W	Warm White
PA	Phosphor Converted Amber
PR	Phosphor Converted Red
UB	Blue
IB	Ice Blue
SB	Sky Blue
UG	Green
UY	Yellow
UA	Amber
UR	Red
SR	Super Red
RGB	RGB-Color

6. Ordering Information

67-41-C70301H-ABCDEFGHIJKLMNO-PQ-AM

Part Number of the 67-41	Order Code
67-41-C70301H-AM	67-41-C70301H-53A64DBBCB2737-2T-AM

Order code contains information with below details :

ABCDEF = min/max wavelength or CCT

GHJK = min./max. luminous flux in [lm] or luminous intensity in [mcd]

LMNO = min./max. forward voltage

PQ = internal code

AM = Automotive Application

7. Reliability Test

No.	Test Items	Test Condition	Test sample Q'ty	Reference Specification
1	PreCon	-40-60deg, Curing 125deg, 24h / 60deg, 60%RH, 40hrs, Reflow 3 times	693, 3 lots	AEC-Q101 Rev. C
2	Solderability	1) For SnPb, 16HR @ 155°C, then Solder dip 235°C, 3 Sec, 1 time	30, 3 lots	AEC-Q101 Rev. C
3	Resistance to Solder Heat	Tsol=260deg, Time > 255 deg = 30sec, Time > 217 deg = 90 sec, 3 times	30	AEC-Q101 Rev. C GQAS from VDO
4	Temperature Cycle	100deg to -40deg, Dwell time = 15min. Transfer 5 minutes, air-to-air 1000 cycles, test at 0, 168, 500, 1000	231, 3 lots	AEC-Q101 Rev. C
5	High Temp. / Humidity Operational Life	85deg, RH=85%, 1000h, I rated, 1000h, test at 0, 168, 500, 1000h	77	JIS C7021 Method B-11 Condition C
6	Humidity with Reverse Bias	85deg, 85%RH, -5V, 1000h, test at 0, 168, 500, 1000h	231, 3 lots	Everlight internal reference
7	Low Temperature Storage	-40deg, 1000h, test at 0, 168, 500, 1000 hr	77	JIS C 7021 Method B-10
8	High Temperature Storage	110deg, 1000h, test at 0, 168, 500, 1000h	77	JIS C 7021 Method B-10
9	Room temperature life test-1	Ta=25°C, 100hrs, I max, test at 0, 168, 500, 1000h	77	Everlight internal reference
10	High temperature life test	Ta=100deg, 1000h, I rated, test at 0, 168, 500, 1000h	77	Everlight internal reference
11	Low temperature life test	Ta=-40deg, 1000h, I max, test at 0, 168, 500, 1000h	77	Everlight internal reference
12	Power Temperature Cycle (PTC)	-40 °C ~ 100 °C, I rated, Dwell/transfer time=15mins, 2 mins on/off 15,000 cycles, test at 0, 2500, 7,500, 15,000 power cycles	231, 3 lots	AEC-Q101 Rev. C
13	ESD Human Body Model	2000V, 3 times, interval: 0.5sec, 40%RH	30	AEC-Q101 Rev. C
14	ESD Machine Model	200V, 3 times, interval: 0.5sec, 40%RH	30	AEC-Q101 Rev. C

Failure Criteria:

Luminous Flux ; +/-20%, Forward Voltage ; +/-10%, Color Coordinates x,y ; +/-0.01, Color wavelength; +/- 0.5nm °

8. Mechanical Dimension

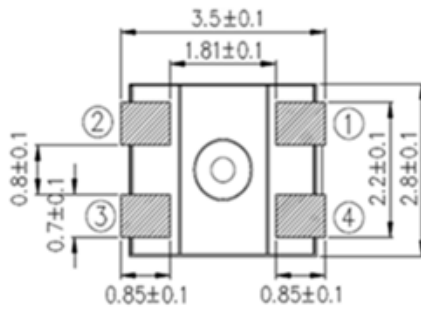
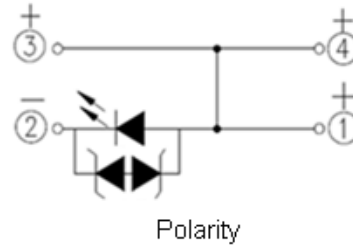
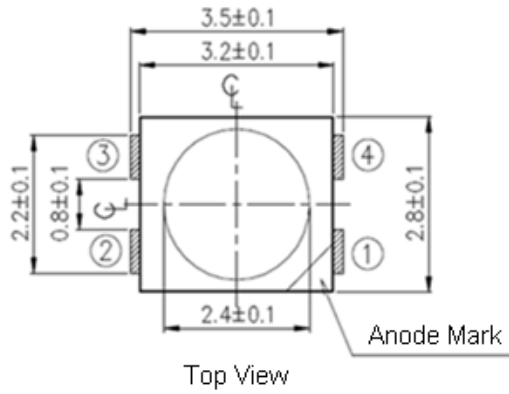

Notes:

1. Dimensions are in millimeters.
2. Tolerances unless mentioned are ± 0.1 mm.

9. Recommended Soldering Pad

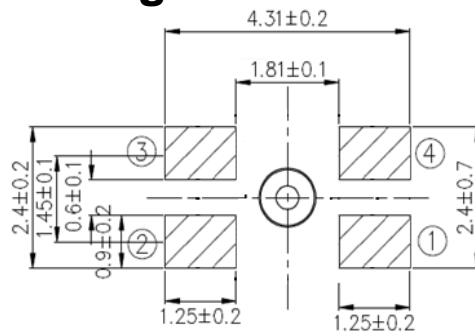

Recommended Soldering
Pattern Layout

10. Reflow Soldering Profile

Soldering Condition (Reference: IPC/JEDEC J-STD-020D)

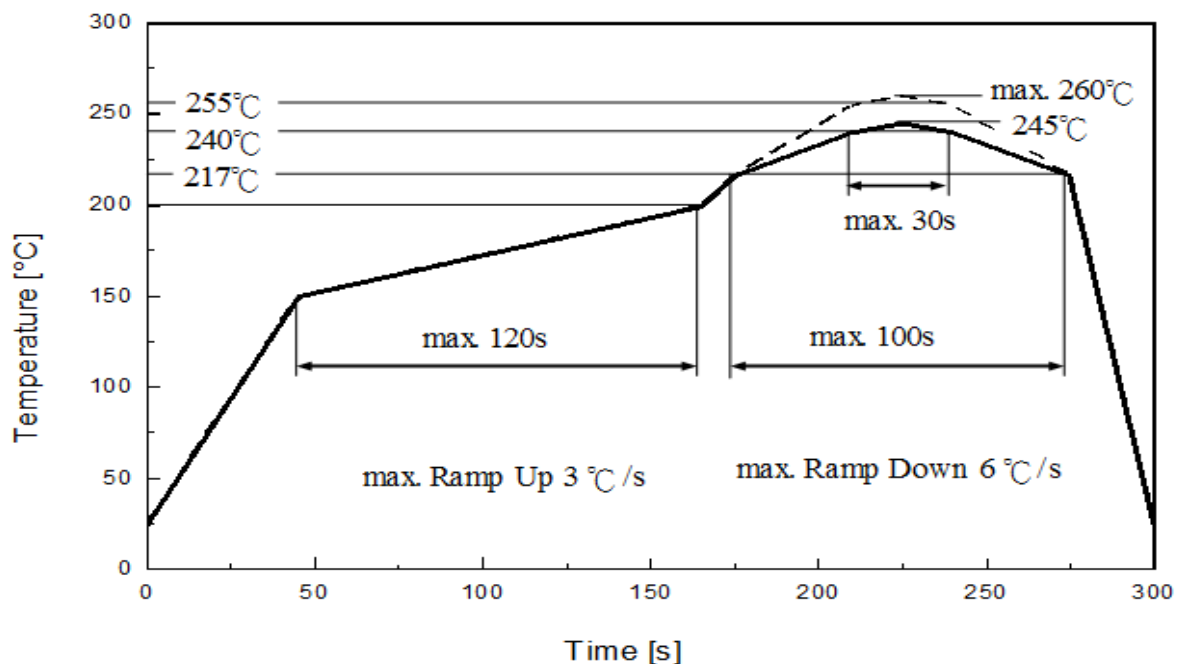

Profile Feature	Pb-Free Assembly	Unit
	Recommendation	
Ramp-up rate to preheat 25 °C to 150 °C	3	°C /sec
Time of soaking zone 150 °C to 200 °C	120	sec
Ramp-up rate to peak	3	°C /sec
Liquefied temperature	217	°C
Time above liquefied temperature	100	sec
Peak temperature (max.)	260	°C
Time within 5°C of the specified peak temperature	30	sec
Ramp-down Rate (max.)	6	°C /sec

11. Packaging Information

• Product Labeling



- CPN : Customer's Product Number
- P/N : Everlight Part Number
- QTY : Packing Quantity
- CAT : Luminous Flux (Brightness) Bin
- HUE : Color Bin
- REF : Forward Voltage Bin
- LOT No : Lot Number

• Packing: Loaded Quantity 2000 pcs Per Reel

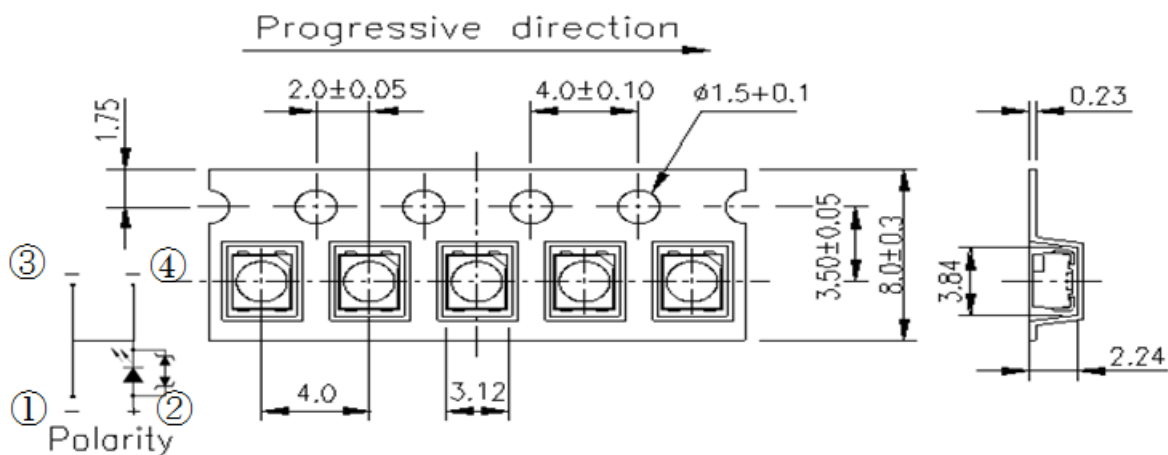

Notes:

1. Dimensions are in millimeters.
2. Tolerances for fixed dimensions are $\pm 0.2\text{mm}$.

● Reel Dimensions

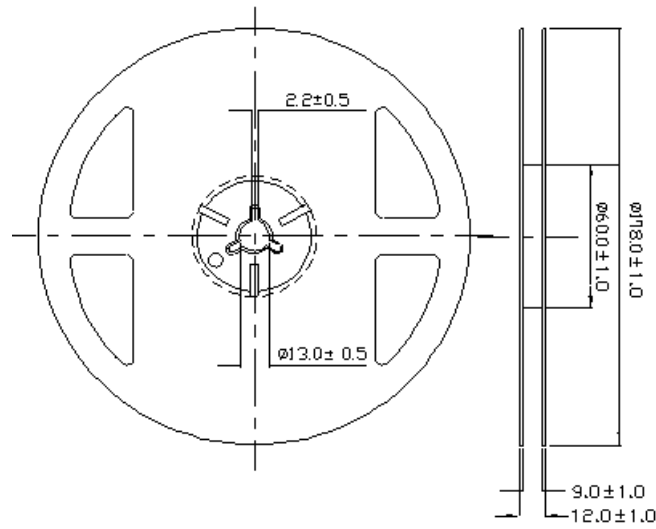

Notes:

1. Dimensions are in millimeters.
2. Tolerances unless mentioned are ± 0.2 mm.

● Moisture Resistant Packing Process

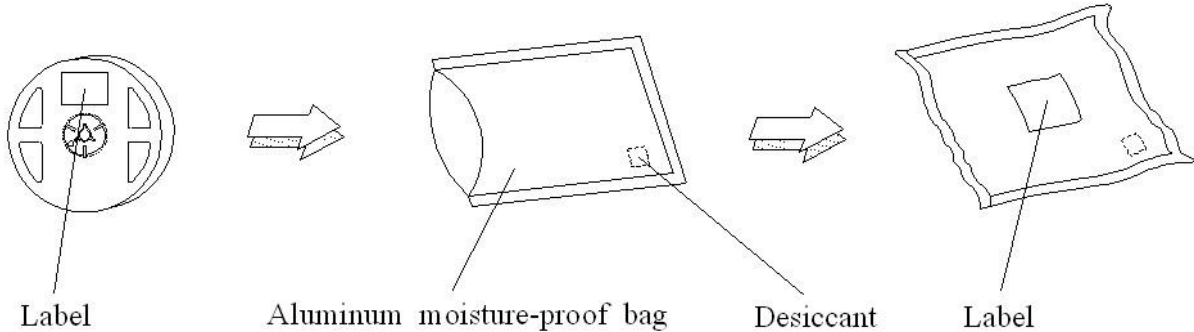

Notes:

1. Dimensions are in millimeters.
2. Tolerances unless mentioned are ± 0.2 mm.

12. Precaution for Use

1. Over-current-proof

Customer must apply resistors for protection; otherwise slight voltage shift will cause big current change (burn out will happen).

2. Assemblies

Do not stack assemblies containing LEDs to prevent damage to the optical surface of LEDs. Forces applied to the optical surface may result in the surface being damaged.

3. Soldering Condition

3.1 When soldering, do not put stress on the LEDs during heating.

3.2 After soldering, do not warp the circuit board.

4. Soldering Iron

Each terminal is to go to the tip of soldering iron temperature less than 350°C for 3 seconds within once in less than the soldering iron capacity 25W. Leave two seconds and more intervals, and do soldering of each terminal. Be careful because the damage of the product is often started at the time of the hand solder.

5. Repairing

Repair should not be done after the LEDs have been soldered. When repairing is unavoidable, a double-head soldering iron should be used (as below figure). It should be confirmed beforehand whether the characteristics of the LEDs will or will not be damaged by repairing.

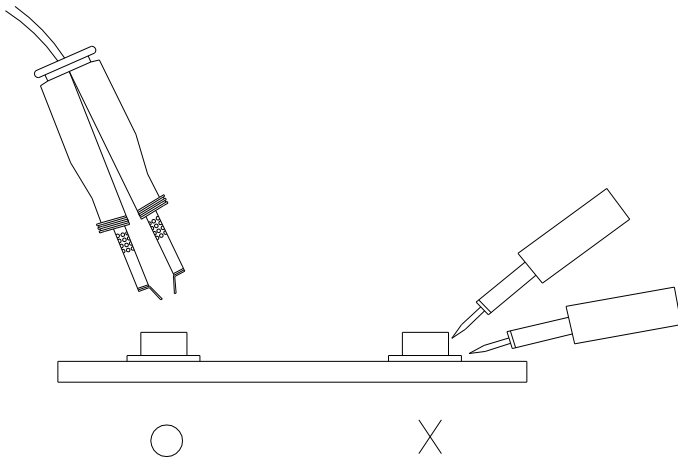

Revision History

Current version: Sep.07.2016

Issue No:

Version: 1.0

Created by: Mark Lai

Rev.	Subjects (major change in previous version)	Modified date
1.0	Standard data sheet	2016/09/07