

### Ambient Light Sensor – DIP 5mm T-1 3/4 EAALST05RDDA0



#### Features

- Close responsively to the human eye spectrum
- Light to Current, analog output
- Good output linearity across wide illumination range
- Low sensitivity variation across various light sources
- Operation temperature performance, -40°C to 85°C
- Wide supply voltage range, 2.5V to 5.5V
- Size: 5mm Lamp
- RoHS compliant and Pb free package
- Compliance with EU REACH.

#### Description

The EAALST05RDDA0 is an ambient light sensor. It consists of a phototransistor in 5mm lamp. Everlight Americas ALS series products are good effective solution to the power saving of display backlighting of mobile appliances, such as the mobile phones, NB and PDAs. Due to the high rejection ratio of infrared radiation, the spectral response of the ambient light sensor is close to human eyes.

#### Applications

- Ambient light monitoring device for daylight and artificial light
  - CCD camera/CCTV security equipment, Street light
- Detection of ambient light to control display backlighting
  - Computing device – TFT LCD monitor for Notebook computer
  - Consumer device – TFT LCD TV, video camera, digital camera, toys

### Package Dimensions

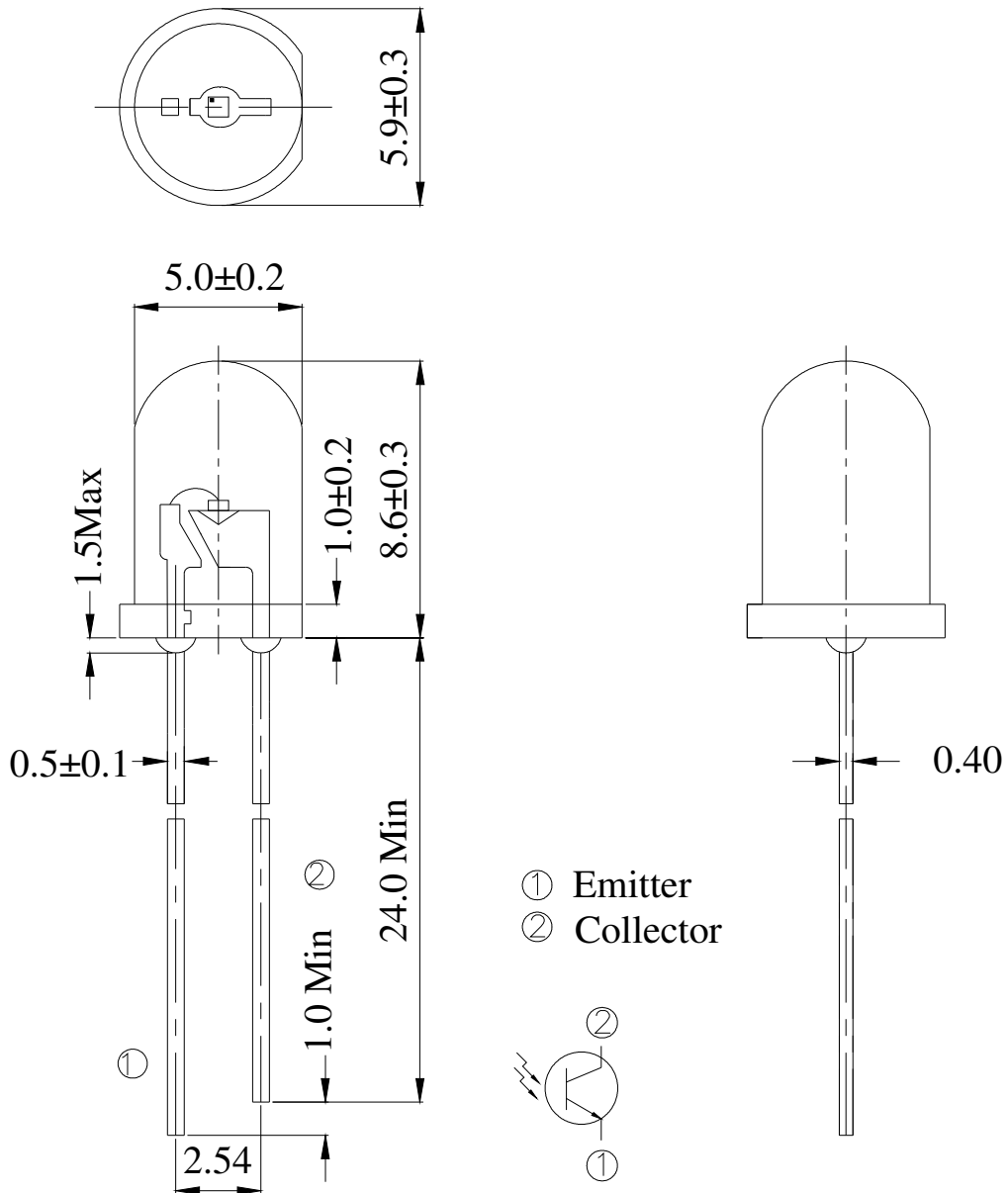

### Notes:

1. All dimensions are in millimeters
2. Tolerances unless dimensions  $\pm 0.1$  mm

### Absolute Maximum Ratings

Parameter	Symbol	Rating	Unit
Supply Voltage	V <sub>CC</sub>	-0.5~6.0	V
Operating Temperature Range	T <sub>opr</sub>	-40~+85	°C
Storage Temperature Range	T <sub>stq</sub>	-40~+100	°C

### Recommended Operating Conditions

Parameter	Symbol	Min.	Max.	Unit
Operating Temperature	T <sub>opr</sub>	-40	+85	°C
Supply Voltage	V <sub>CC</sub>	2.5	5.5	V

### Electro-Optical Characteristics (Ta=25°C)

Parameter	Symbol	Min.	Typ.	Max.	Unit	Condition
Dark Current	$I_D$	1	---	100	nA	$V_{CE}=5V$ $E_V=0Lux$
Light Current	$I_{PH1}$	90	---	160	uA	$V_{CE}=5V$ $E_V=100Lux$ <a href="#">[Note1]</a>
	$I_{PH2}$	900	---	1600		$V_{CE}=5V$ $E_V=1000Lux$ <a href="#">[Note1]</a>
	$I_{PH3}$	---	5.4	---	mA	$V_{CE}=5V$ $E_V=1000Lux$ <a href="#">[Note2]</a>
Photocurrent Ratio	$I_{PH3} / I_{PH2}$	---	4.5	---	---	$V_{CE}=5V$ $E_V=1000Lux$
Peak Sensitivity Wavelength	$\lambda_p$	---	560	---	nm	---
Sensitivity Wavelength Range	$\lambda$	390	---	700	nm	---
Rise Time	$t_r$	---	0.08	---	ms	$V_{CE}=5V$
Fall Time	$t_f$	---	0.09	---	ms	$R_L = 5.1K\Omega$
Angle of half Sensitivity	$2\theta_{1/2}$	---	64	---	Deg	$I_F = 20 mA$

Note:

1. White Fluorescent light (Color Temperature = 6500K) is used as light source. However, White LED is substituted in mass production.
2. Illuminance by CIE standard illuminant-A / 2856K, incandescent lamp.

**Typical Electro-Optical Characteristics Curves**

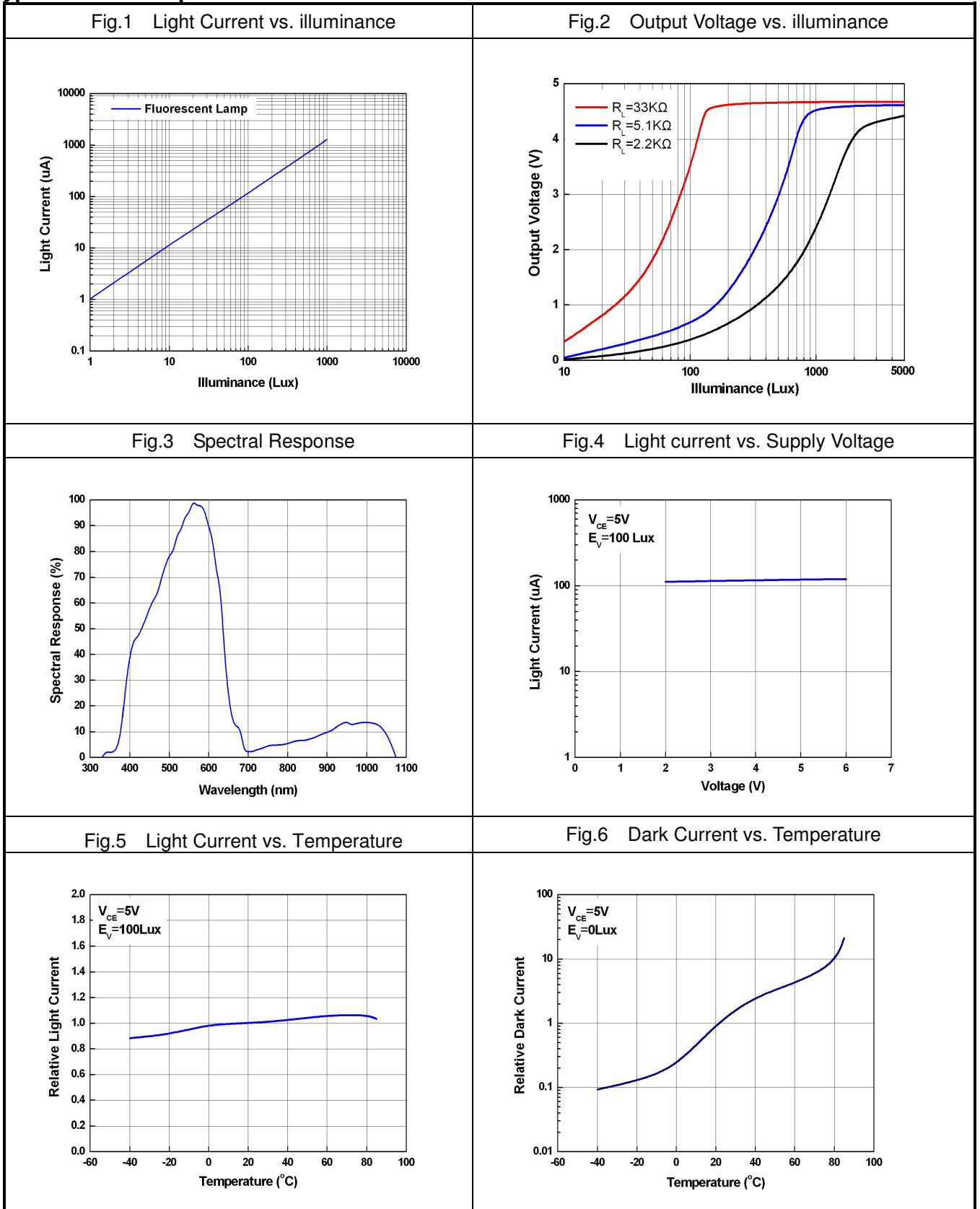

## Converting Photocurrent to Voltage

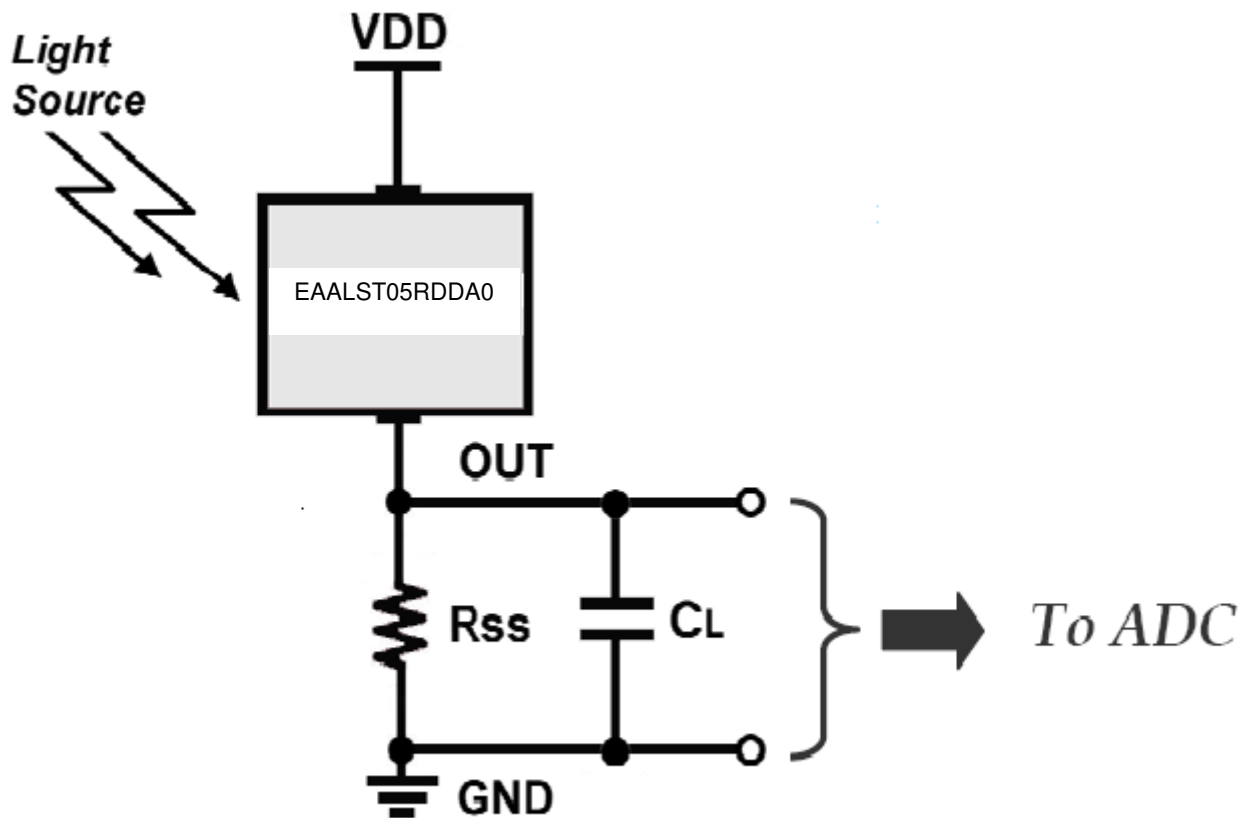

### Note :

1. The output voltage (V<sub>out</sub>) is the product of photocurrent (I<sub>PH</sub>) and loading resistor (R<sub>L</sub>)
2. A right loading resistor shall be chosen to meet the requirement of maximum ambient light, and output saturation voltage:

$$V_{out(max.)} = I_{out(max.)} \times R_L \leq V_{out(saturation)} = V_{cc} - 0.4V$$

## Packing Quantity Specification

1.500PCS/1Bag · 5Bags/1Box

2.10Boxes/1Carton

## Label Format

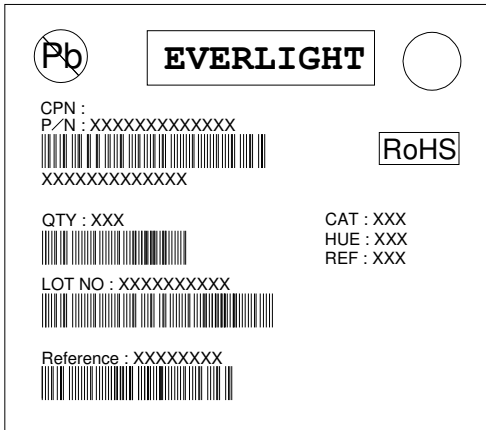

- CPN : Customer's Product Number
- P/N : Product Number
- QTY : Packing Quantity
- CAT : Ranks
- HUE : Peak Wavelength
- REF : Reference
- LOT No : Lot Number

## Note :

1. Above specification may be changed without notice. Everlight Americas will reserve authority on material change for above specification.
2. When using this product, please observe the absolute maximum ratings and the instructions for using outlined in these specification sheets. Everlight Americas assumes no responsibility for any damage resulting from use of the product which does not comply with the absolute maximum ratings and instructions included in these specification sheets.
3. These specification sheets include materials protected under copyright of Everlight Americas Inc. Please don't reproduce or cause anyone to reproduce them without Everlight Americas's consent.