

SMD ■ Technical Data Sheet EAHP5630GA0



Features

- Top view LED
- High luminous flux output
- High current capability
- White package
- Wide viewing angle
- Pb-free
- The product itself will remain within RoHS compliant version.
- Precondition: Bases on JEDEC J-STD 020D Level 3

Descriptions

Due to the package design, EAHP5630GA0 has wide viewing angle. This feature makes the LED ideal for light guide application.

Applications

- Decorative and Entertainment Lighting.
- Light pipe application
- Indicator and backlight in office and family equipment
- General use

Device Selection Guide

Chip Materials	Emitted Color	Resin Color
InGaN	Brilliant Green	Water Clear

Absolute Maximum Ratings (Ta=25°C)

Parameter	Symbol	Rating	Unit
Reverse Voltage	V_R	5	V
Forward Current	I_F	150	mA
Peak Forward Current (Duty 1/10 @1KHz)	I_{FP}	100	mA
Power Dissipation	P_d	95	mW
Junction Temperature	T_j	125	°C
Operating Temperature	T_{opr}	-40 ~ +85	°C
Storage Temperature	T_{stg}	-40 ~ +90	°C
Thermal Resistance	$R_{th\ J-A}$	150	K/W
	$R_{th\ J-S}$	100	K/W
ESD (Classification acc. AEC Q101)	ESD_{HBM}	2000	V
	ESD_{MM}	200	V
Soldering Temperature	T_{sol}	Reflow Soldering : 260 °C for 30 sec. Hand Soldering : 350 °C for 3 sec.	

Electro-Optical Characteristics (Ta=25°C)

Parameter	Symbol	Min.	Typ.	Max.	Unit	Condition
Luminous Intensity	I _v	5600	-----	11200	mcd	I _F =150mA
Viewing Angle	2θ _{1/2}	-----	120	-----	deg	I _F =150mA
Peak Wavelength	λ _p	-----	518	-----	nm	I _F =150mA
Dominant Wavelength	λ _d	519	-----	531	nm	I _F =150mA
Spectrum Radiation Bandwidth	Δλ	-----	35	-----	nm	I _F =150mA
Forward Voltage	V _F	2.7	-----	3.7	V	I _F =150mA
Reverse Current	I _R	-----	-----	10	μA	V _R =5V

Note:

1. Tolerance of Luminous Intensity: ±11%
2. Tolerance of Dominant Wavelength: ±1nm
3. Tolerance of Forward Voltage: ±0.1V

Bin Range of Luminous Intensity

Bin Code	Min.	Max.	Unit	Condition
DB	5600	7100	mcd	I _F =150mA
EA	7100	9000		
EB	9000	11200		

Note:

Tolerance of Luminous Intensity: ±11%

Bin Range of Dominant Wavelength

Bin Code	Min.	Max.	Unit	Condition
AA7	519	522	nm	IF =150mA
AA8	522	525		
AA9	525	528		
AA10	528	531		

Note:

Tolerance of Dominant Wavelength: ±1nm

Bin Range of Forward Voltage

Bin Code	Min.	Max.	Unit	Condition
10	2.7	2.9	V	IF =150mA
11	2.9	3.1		
12	3.1	3.3		
13	3.3	3.5		
14	3.5	3.7		

Note:
Tolerance of Forward Voltage: $\pm 0.1V$

Typical Electro-Optical Characteristics Curves

Typical Curve of Spectral Distribution

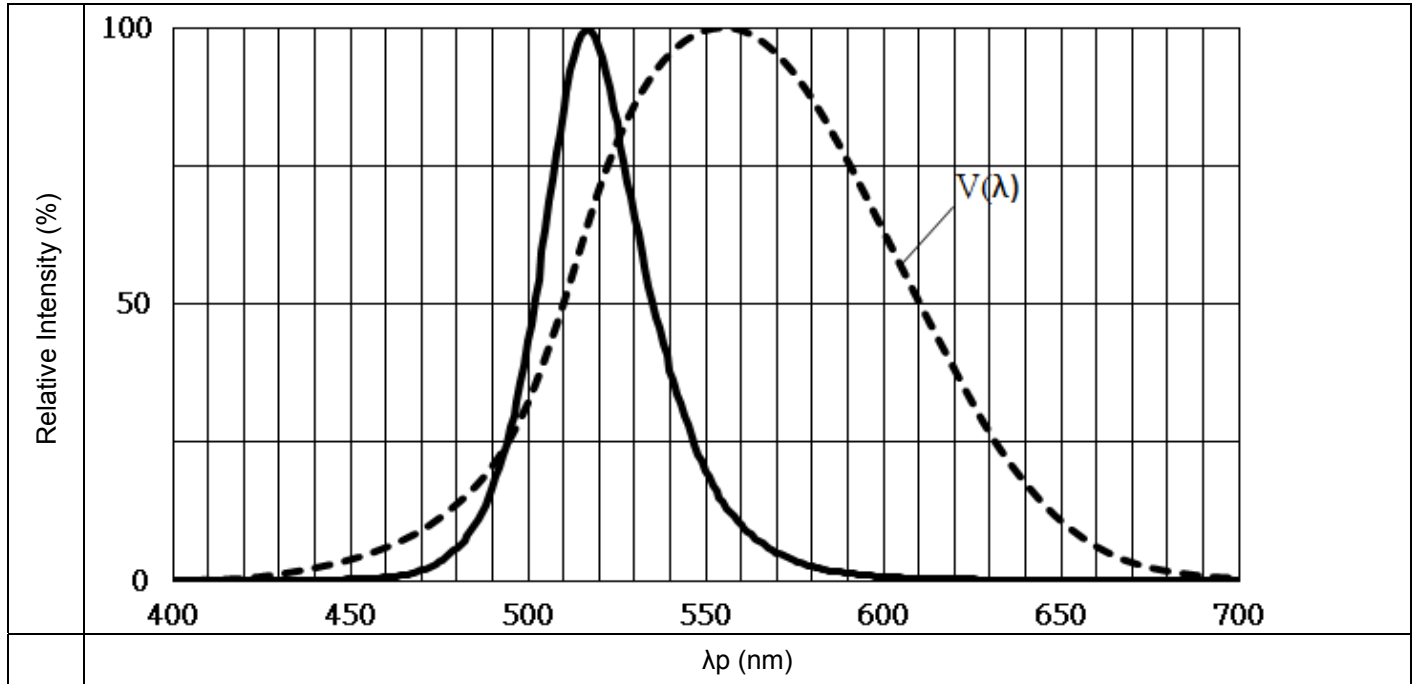

Note: $V(\lambda)$ = Standard eye response curve; $I_F = 150\text{mA}$

Diagram Characteristics of Radiation

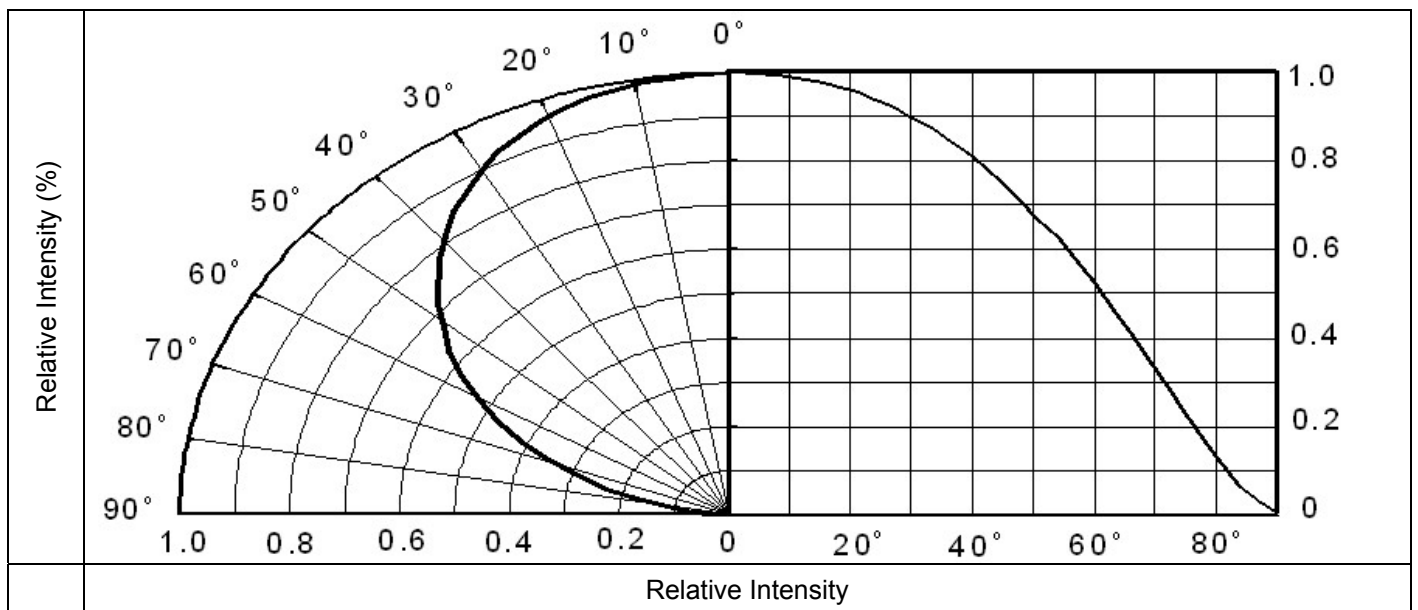

Forward Current vs. Forward Voltage (Ta=25°C)

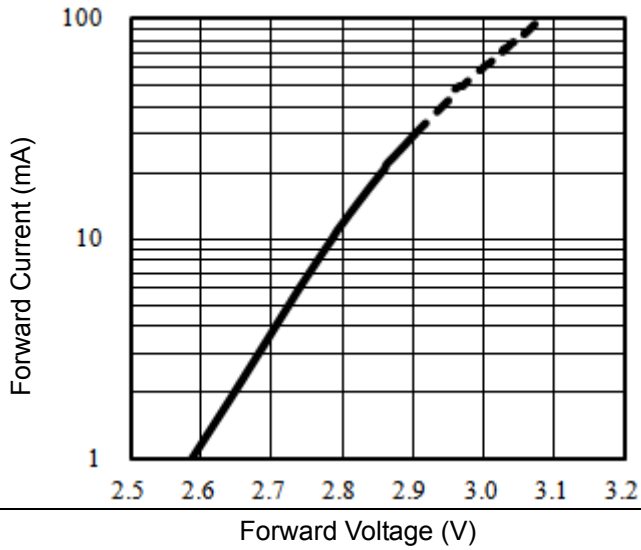

Dominant Wavelength vs. Forward Current (Ta=25°C)

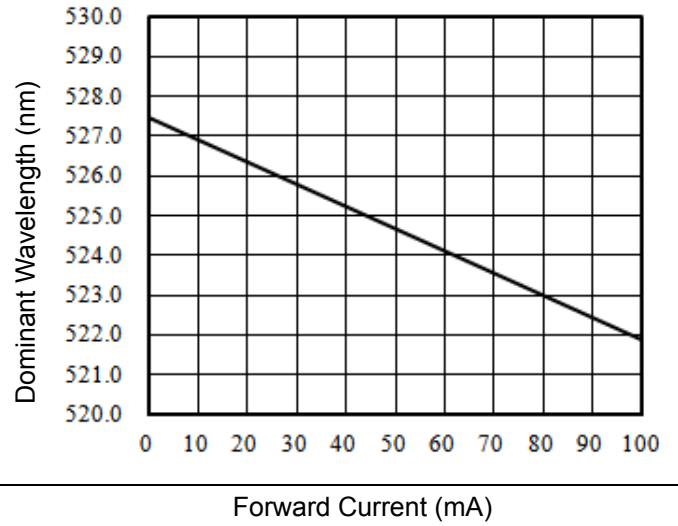

Relative Luminous Intensity vs. Forward Current (Ta=25°C)

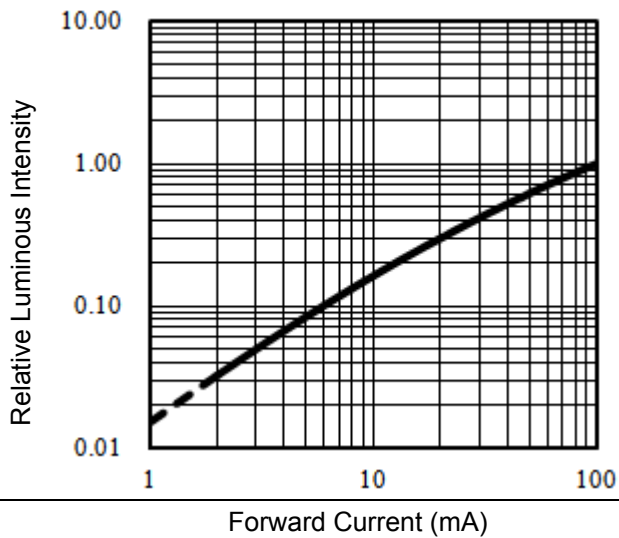

Max. Permissible Forwarded Current (Ta=25°C)

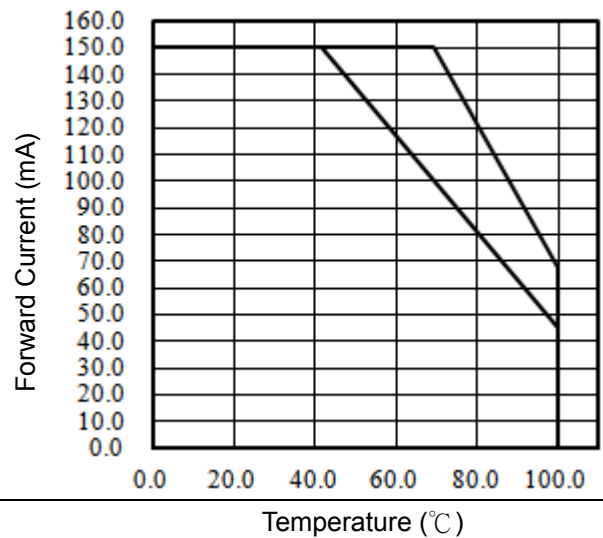

Package Dimension

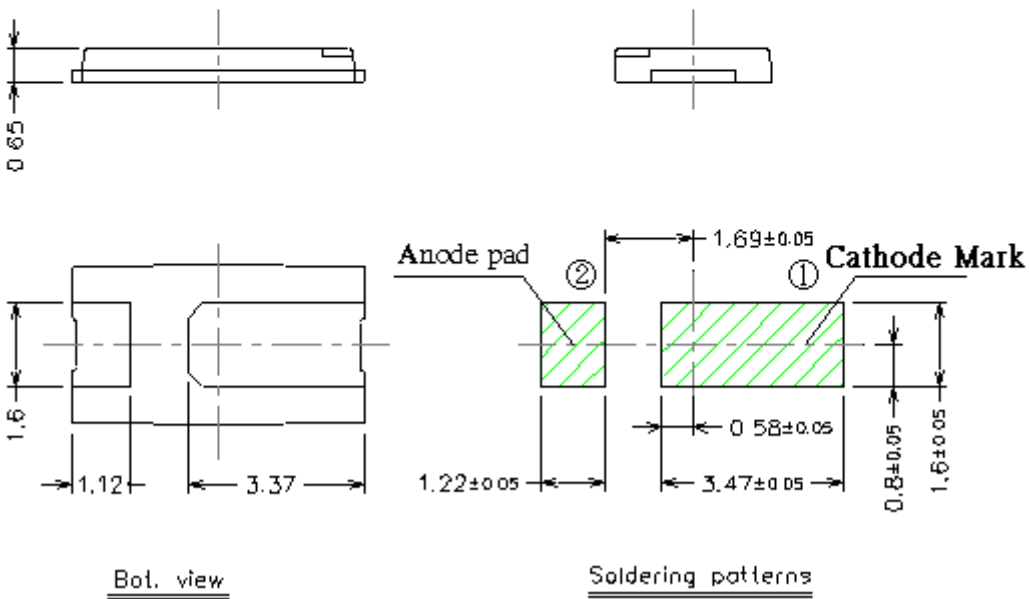
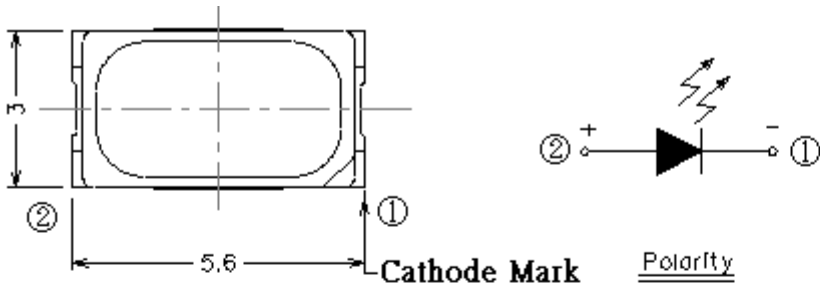

Note: Tolerances unless mentioned ±0.1mm. Unit = mm

Moisture Resistant Packing Materials

Label Explanation

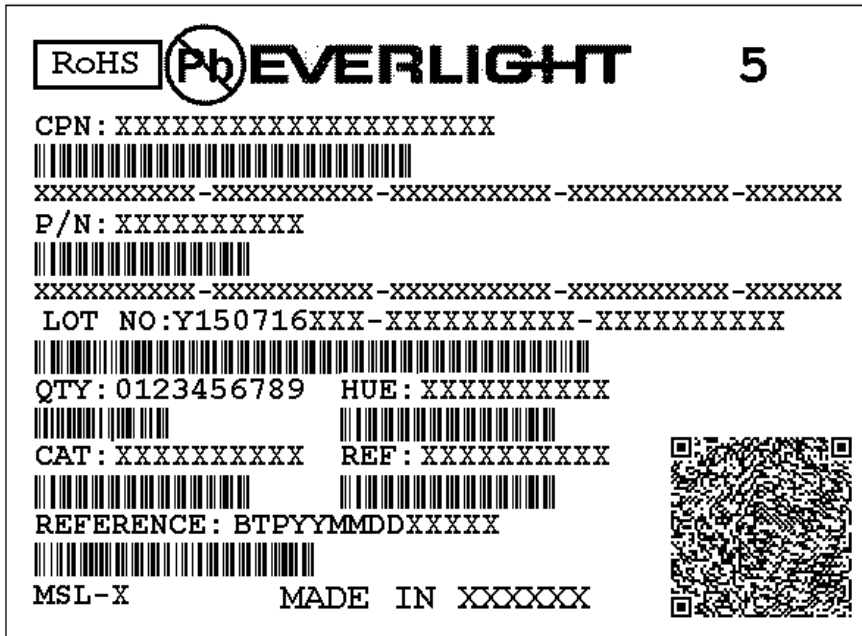

- CPN: Customer's Product Number
- P/N: Product Number
- QTY: Packing Quantity
- CAT: Luminous Intensity Rank
- HUE: Dom. Wavelength Rank
- REF: Forward Voltage Rank
- LOT No: Lot Number

Reel Dimensions

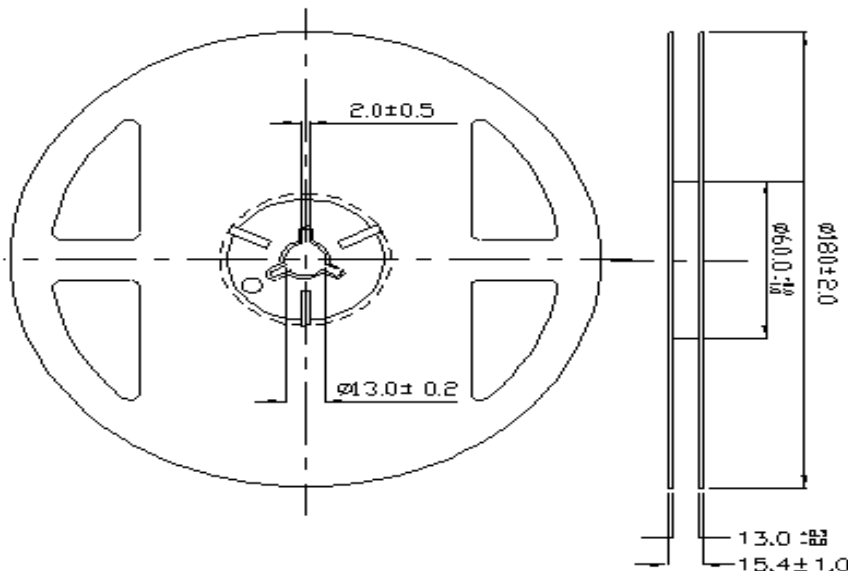

Carrier Tape Dimensions: Loaded Quantity 2000 pcs Per Reel

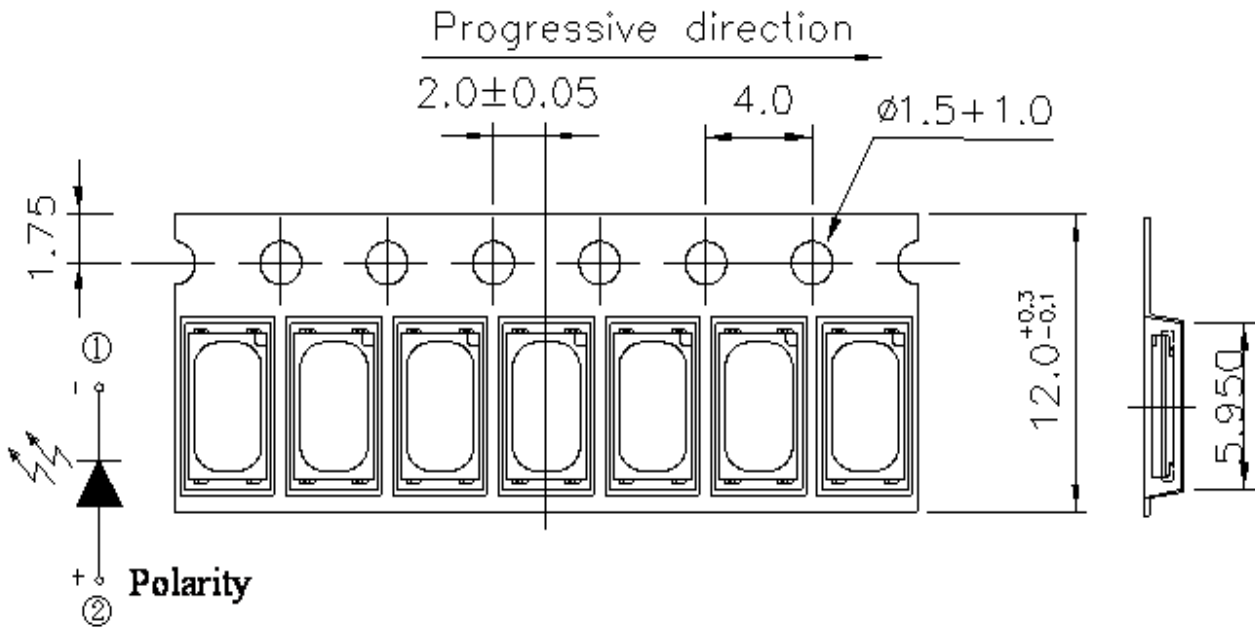

Note: Tolerances unless mentioned ± 0.1 mm. Unit = mm

Moisture Resistant Packing Process

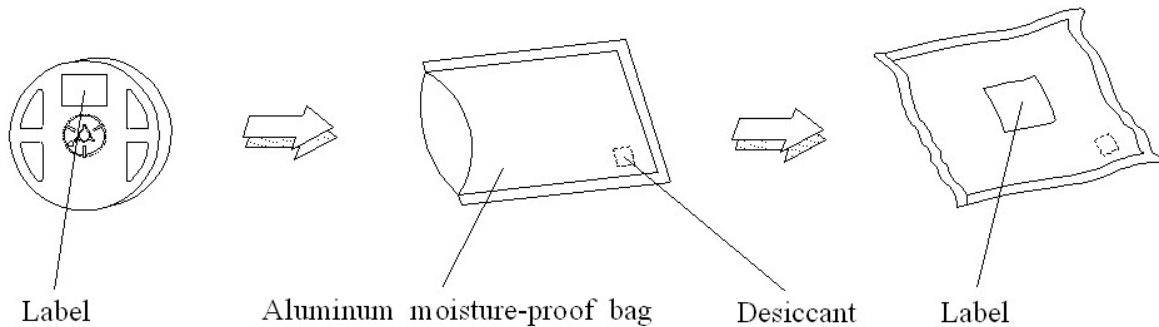

Note: Tolerances unless mentioned $\pm 0.1\text{mm}$. Unit = mm

Precautions for Use

1. Over-current-proof

1.1 Customer must apply resistors for protection, otherwise slight voltage shift will cause big current change (Burn out will happen).

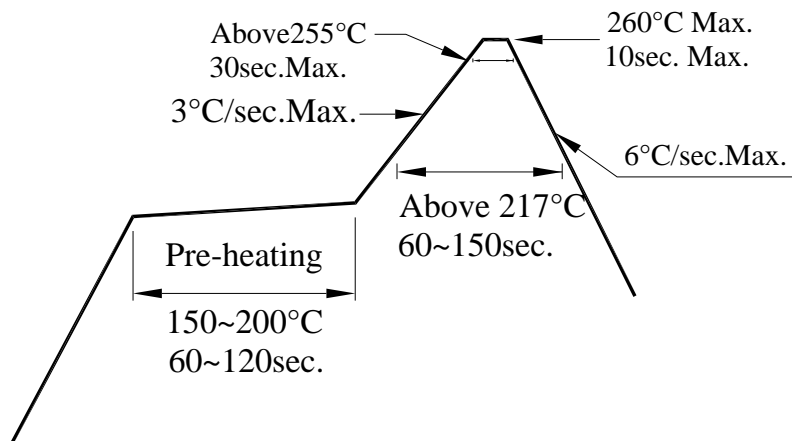

2. Storage

2.1 Don't open moisture proof bag before the products are ready to use.

2.2 Before opening the package: The LEDs should be kept at 30°C or less and 90%RH or less.

2.3 After opening the package: The LED's floor life is 72Hrs under 30°C or less and 60% RH or less. If unused LEDs remain, it should be stored in moisture proof packages.

2.4 If the moisture absorbent material (silica gel) has faded away or the LEDs have exceeded the storage time, baking treatment should be performed using the following conditions. baking treatment: $60\pm 5^\circ\text{C}$ for 24 hours

3. Soldering Condition

3.1 Pb-free solder temperature profile

3.2 Reflow soldering should not be done more than two times.

3.3 When soldering, do not put stress on the LEDs during heating.

3.4 After soldering, do not warp the circuit board.

4. Soldering Iron

Each terminal is to go to the tip of soldering iron temperature less than 350°C for 3 seconds within once in less

than the soldering iron capacity 25W. Leave two seconds and more intervals, and do soldering of each terminal. Be careful because the damage of the product is often started at the time of the hand solder.

5. Repairing

Repair should not be done after the LEDs have been soldered. When repairing is unavoidable, a double-head soldering iron should be used (as below figure). It should be confirmed beforehand whether the characteristics of the LEDs will or will not be damaged by repairing.

Application Restrictions

High reliability applications such as military/aerospace, automotive safety/security systems, and medical equipment may require different product. If you have any concerns, please contact Everlight before using this product in your application. This specification guarantees the quality and performance of the product as an individual component. Do not use this product beyond the specification described in this document.

Revision History

Rev.	Modified date	File modified contents
1	2014/11/17	New Spec
2	2015/06/30	Approved
3	2016/01/28	Correction Description