

EL Power TOP VIEW LED 67-31-C70301H-AM

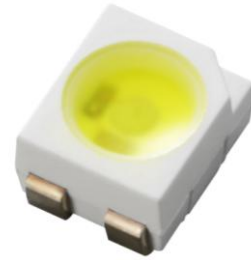

Features

- Package : Cool White LED with PLCC 3 package
- Emitted Color : Cool White
- Typ. Luminance Intensity : 2,800 mcd @ 30mA
- Typ. Luminous Flux : 8.5 lm @ 30mA
- Viewing angle : 120°
- ESD; up to 8KV
- Qualifications; According to AEC-Q101
- Compliance with RoHS and REACH
- Au Plating L/F

Applications

- Automotive Interior Lighting , Dashboard, Switch, Reading lamp, Audio and Car Infotainment....etc
- Backlight: LCD, switches, symbol, mobile phone and illuminated advertising.
- Optical indicator.
- General applications.

Contents

| | |
|---------------------------------------|-----------|
| Characteristics | 3 |
| Absolute Maximum Ratings | 4 |
| Characteristics Graph | 5 |
| Binning Information | 11 |
| Part Number | 16 |
| Ordering Information | 17 |
| Reliability Test..... | 18 |
| Mechanical Dimension..... | 19 |
| Recommended Soldering Pad..... | 20 |
| Reflow Soldering Profile | 20 |
| Packaging Information..... | 21 |
| Precaution for Use..... | 22 |

1. Characteristics

| Parameter | | Symbol | Min. | Typ. | Max. | Unit | Condition |
|--|------------|--------------------|------|------|------|------|-------------------|
| Forward Current | Cool White | I_F | 5 | 30 | 70 | mA | --- |
| Luminous Intensity | Cool White | Φ_v | 2240 | 2800 | 4500 | mcd | $I_F=30\text{mA}$ |
| Forward Voltage | Cool White | V_F | 2.75 | 3.1 | 3.75 | V | $I_F=30\text{mA}$ |
| Viewing Angle | Cool White | φ | --- | 120 | --- | deg | $I_F=30\text{mA}$ |
| Color | Cool White | CIE x | --- | 0.31 | --- | --- | $I_F=30\text{mA}$ |
| Color | Cool White | CIE y | --- | 0.32 | --- | --- | $I_F=30\text{mA}$ |
| Thermal Resistance (Junction to Solder) | Real | $R_{th\ JS\ real}$ | --- | 430 | --- | K/W | $I_F=30\text{mA}$ |
| | Electrical | $R_{th\ JS\ el}$ | --- | 250 | --- | | |

Notes:

1. Luminous Intensity measurement tolerance: $\pm 8\%$.
2. The data of Luminous Intensity measured at thermal pad= 25°C .
3. Typical luminous Intensity or light output performance is operated within the condition guided by this datasheet.
4. Forward voltage measurement tolerance: $\pm 0.05\text{V}$.
5. The V_F range shown in the table above indicates 99% output.
6. Tolerance of Chromaticity Coordinates x,y: ± 0.005 .

2. Absolute Maximum Ratings

| Parameter | Symbol | Ratings | Unit |
|--|-------------|------------------------------------|------|
| Power Dissipation | P_d | 225 | mW |
| Forward Current | I_F | 5~70 | mA |
| Reverse Voltage | V_R | Not designed for reverse operation | V |
| Junction Temperature | T_J | 125 | °C |
| Operating Temperature | T_{opr} | -40 ~ +110 | °C |
| Storage Temperature | T_{stg} | -40 ~ +110 | °C |
| ESD Sensitivity (R=1.5kΩ, C= 100pF) | ESD_{HBM} | 8K | V |
| Soldering Temperature | Reflow | 260°C for 30sec | °C |

3. Characteristics Graph

Wavelength Characteristics Relative Spectral Distribution

@ Ts = 25°C, If=30mA, RH=30%

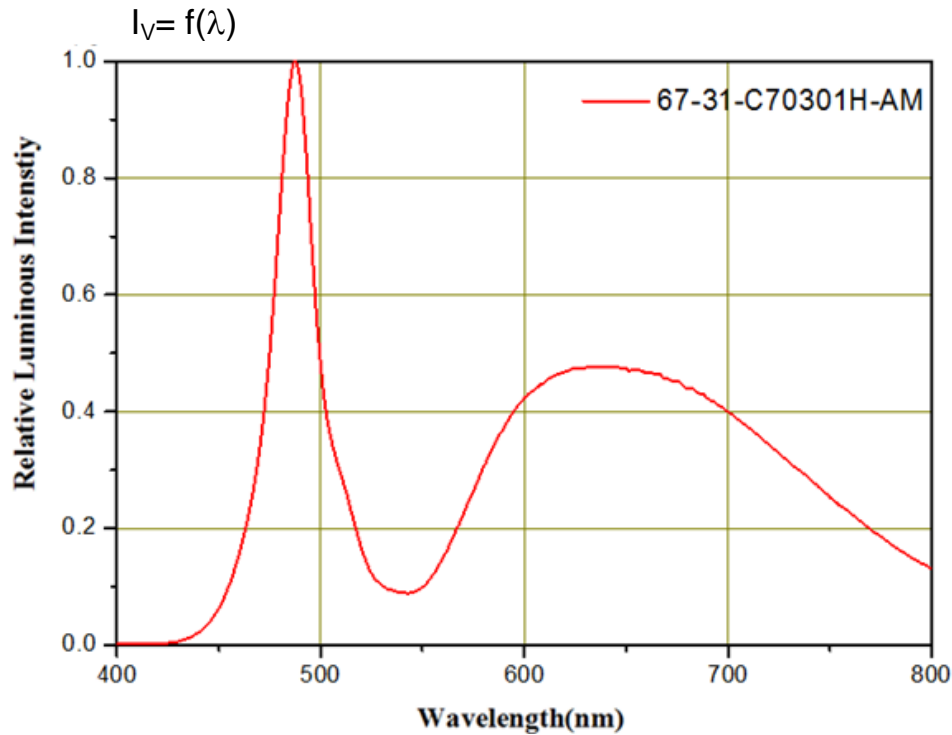

Typical Diagram Characteristics of Radiation

$$\Phi_V / \Phi_V(0^\circ) = f(\varphi)$$

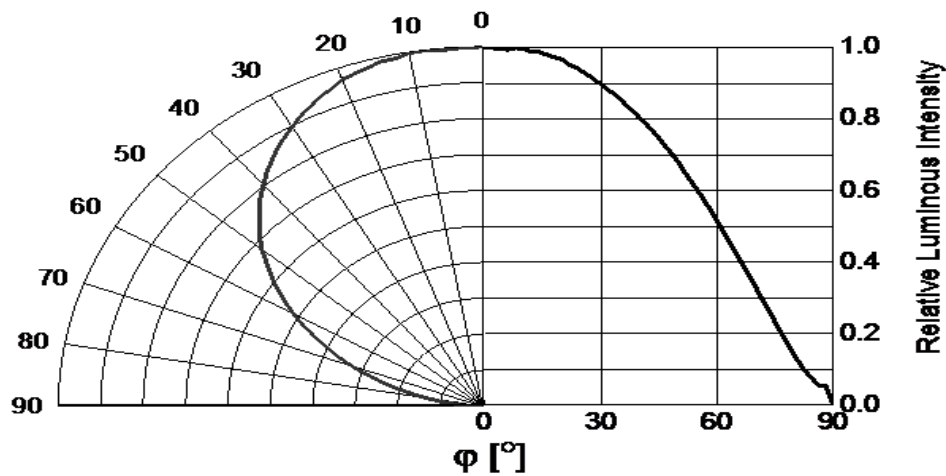

Notes:

1. φ is the off axis angle from lamp centerline where the luminous intensity is 1/2 of the peak value.

Forward Current vs. Forward Voltage

@ Ts = 25°C

$$I_F = f(V_F)$$

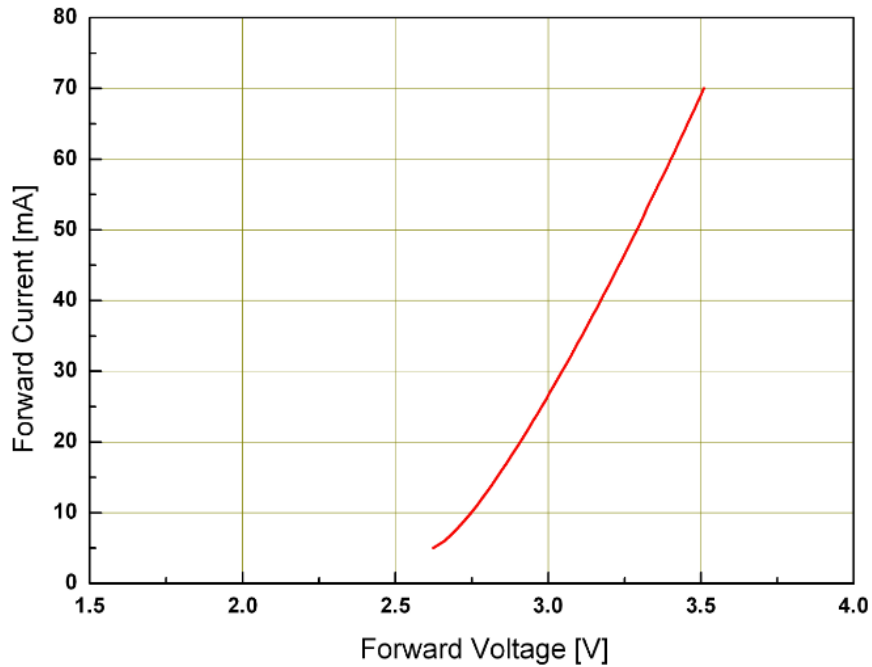

Luminous vs. Forward Current

@ Ts = 25°C

$$I_V / I_{V(30mA)} = f(I_F)$$

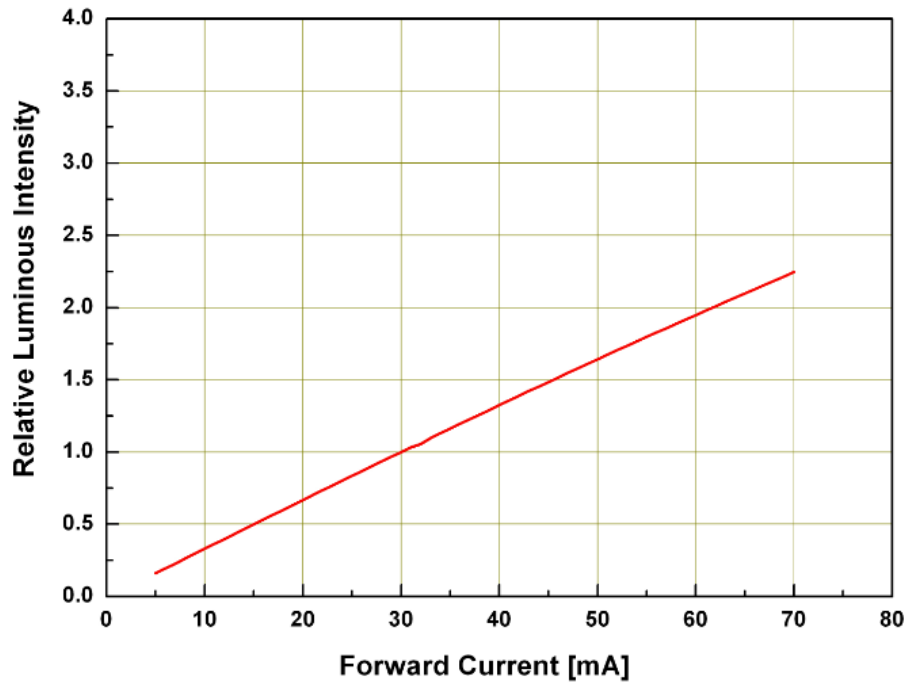

Chromaticity Coordinates Shift vs. Forward Current

@ $T_s = 25^\circ\text{C}$

$$\Delta \text{CIE } x, \Delta \text{CIE } y = f(I_F)$$

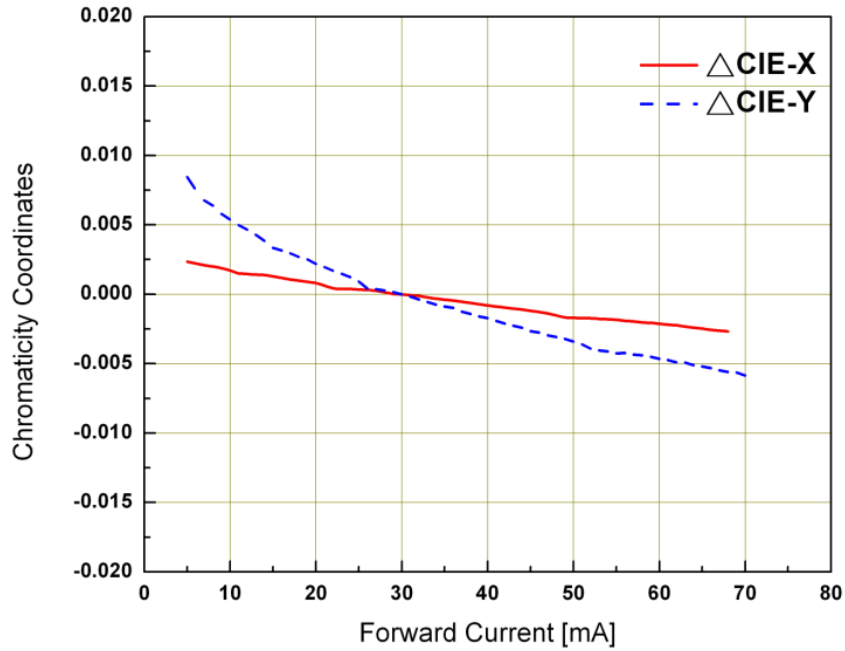

Relative Forward Voltage vs. Junction Temperature

@ $I_F = 30\text{mA}$

$$V_F - V_F(T_{J25^\circ\text{C}}) = f(T_J)$$

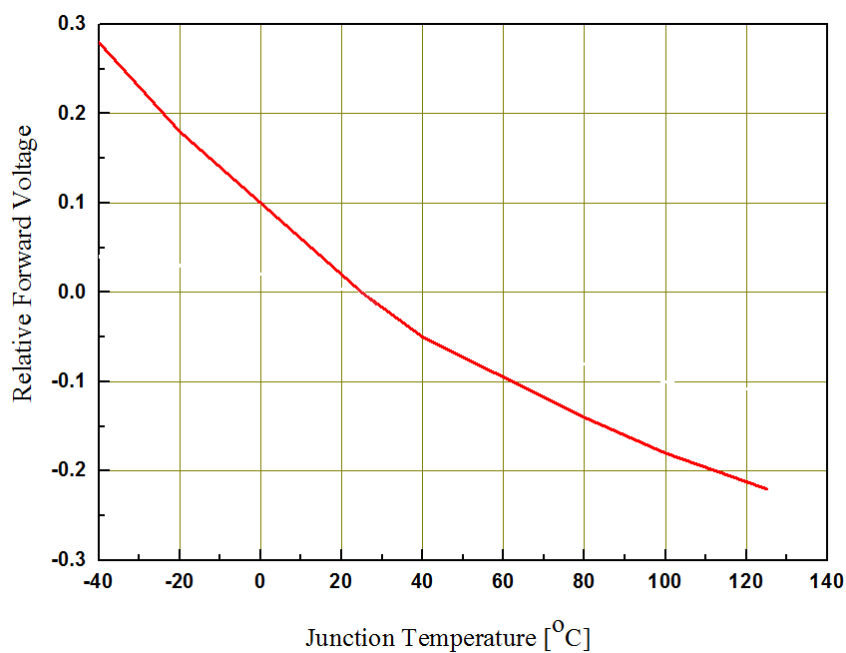

Relative Luminous Intensity vs. Junction Temperature

@ $I_F=30\text{mA}$

$$I_V/I_V(T_J 25^\circ\text{C}) = f(T_J)$$

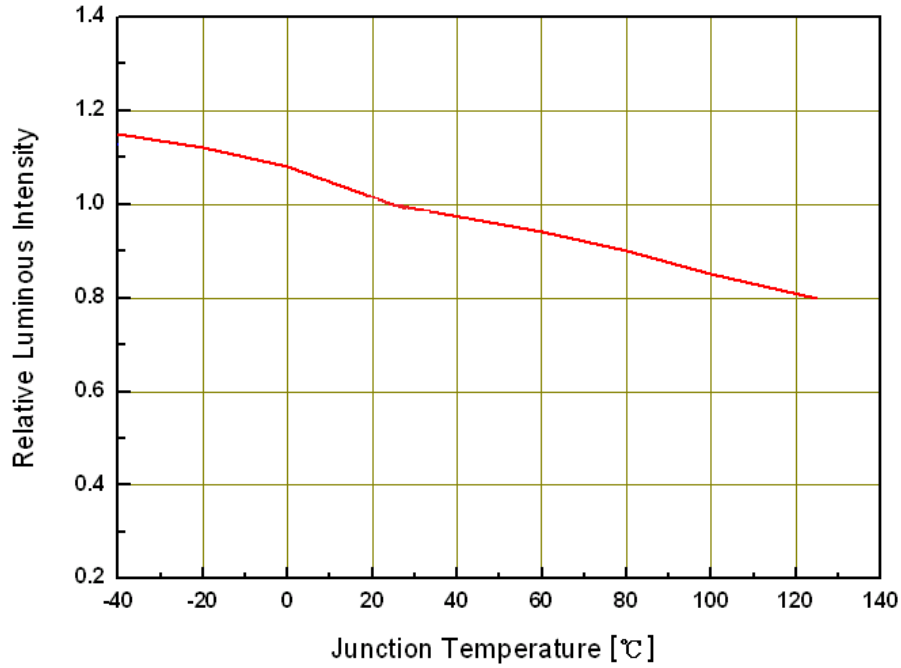

Forward Current Derating Curve

$$I_F = f(T_S)$$

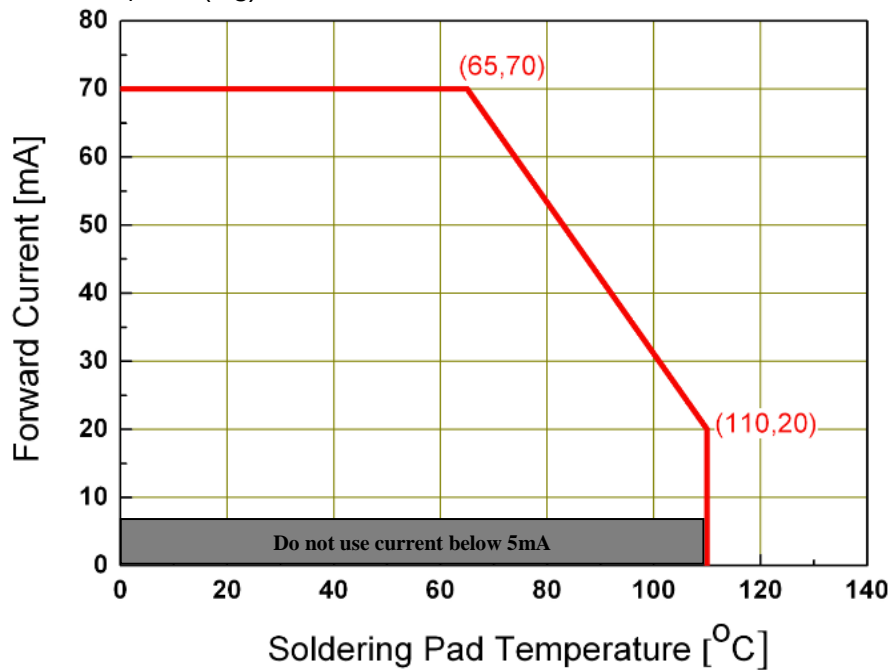

4. Binning Information

Luminous Intensity Bins

| Group Bin | Minimum Luminous Intensity (mcd) | Maximum Luminous Intensity (mcd) |
|-----------|----------------------------------|----------------------------------|
| L1 | 11.2 | 14 |
| L2 | 14 | 18 |
| M1 | 18 | 22.4 |
| M2 | 22.4 | 28 |
| N1 | 28 | 35.5 |
| N2 | 35.5 | 45 |
| P1 | 45 | 56 |
| P2 | 56 | 71 |
| Q1 | 71 | 90 |
| Q2 | 90 | 112 |
| R1 | 112 | 140 |
| R2 | 140 | 180 |
| S1 | 180 | 224 |
| S2 | 224 | 280 |
| T1 | 280 | 355 |
| T2 | 355 | 450 |
| U1 | 450 | 560 |
| U2 | 560 | 710 |
| V1 | 710 | 900 |
| V2 | 900 | 1120 |
| AA | 1120 | 1400 |
| AB | 1400 | 1800 |
| BA | 1800 | 2240 |
| BB | 2240 | 2800 |
| CA | 2800 | 3550 |
| CB | 3550 | 4500 |
| DA | 4500 | 5600 |
| DB | 5600 | 7100 |
| EA | 7100 | 9000 |
| EB | 9000 | 11200 |
| FA | 11200 | 14000 |
| FB | 14000 | 18000 |
| GA | 18000 | 22400 |

Notes:

1. Luminous flux measurement tolerance: $\pm 8\%$.
2. Highlighted Black Box is available bins.

White Color Bin Structure

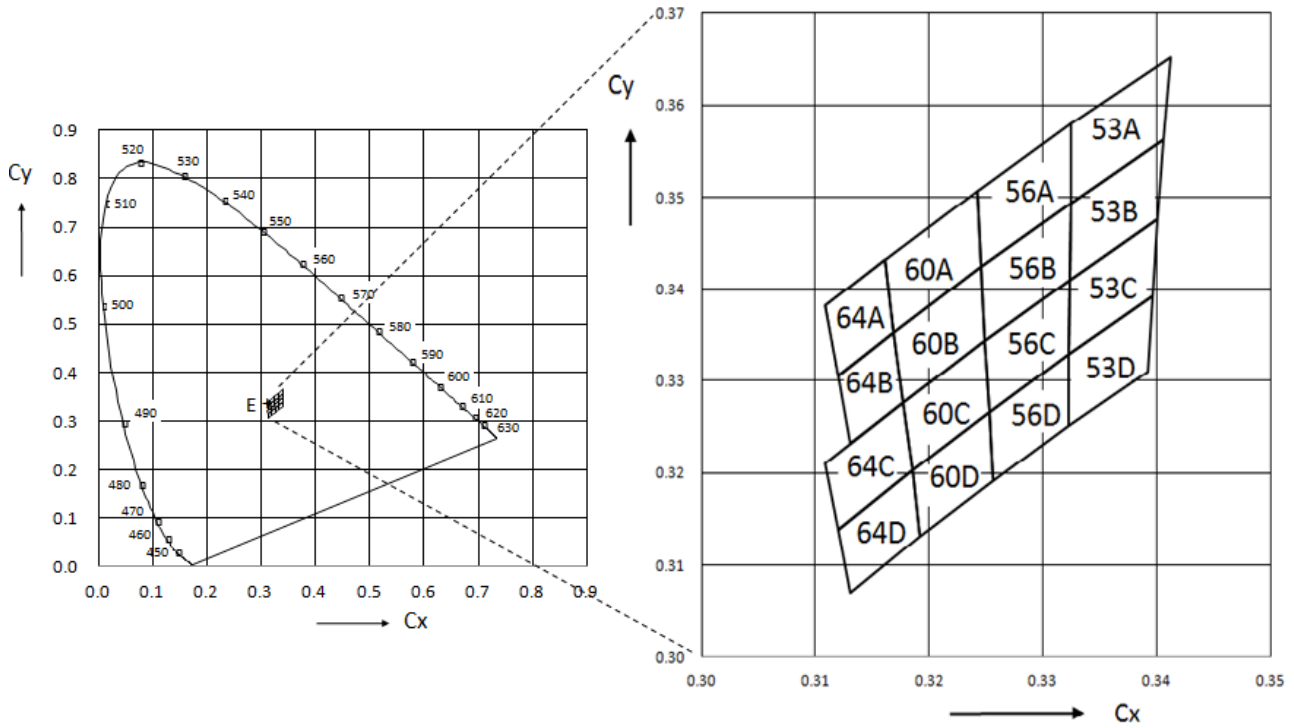

White Color Bin Coordinates

| Bin | CIE x | CIE y |
|-----------------------------|--------|--------|
| 64A | 0.3109 | 0.3382 |
| | 0.3161 | 0.3432 |
| | 0.3169 | 0.3353 |
| | 0.3120 | 0.3306 |
| Reference Range: 6240~6530K | | |

| Bin | CIE x | CIE y |
|-----------------------------|--------|--------|
| 64B | 0.3120 | 0.3306 |
| | 0.3169 | 0.3353 |
| | 0.3177 | 0.3277 |
| | 0.3131 | 0.3232 |
| Reference Range: 6240~6530K | | |

| Bin | CIE x | CIE y |
|-----------------------------|--------|--------|
| 64C | 0.3109 | 0.3211 |
| | 0.3177 | 0.3277 |
| | 0.3185 | 0.3203 |
| | 0.3120 | 0.3139 |
| Reference Range: 6240~6680K | | |

| Bin | CIE x | CIE y |
|-----------------------------|--------|--------|
| 64D | 0.3120 | 0.3139 |
| | 0.3185 | 0.3203 |
| | 0.3192 | 0.3131 |
| | 0.3131 | 0.3070 |
| Reference Range: 6240~6680K | | |

| Bin | CIE x | CIE y |
|-----------------------------|--------|--------|
| 60A | 0.3161 | 0.3432 |
| | 0.3242 | 0.3506 |
| | 0.3246 | 0.3424 |
| | 0.3169 | 0.3353 |
| Reference Range: 5850~6240K | | |

| Bin | CIE x | CIE y |
|-----------------------------|--------|--------|
| 60B | 0.3169 | 0.3353 |
| | 0.3246 | 0.3424 |
| | 0.3249 | 0.3344 |
| | 0.3177 | 0.3277 |
| Reference Range: 5850~6240K | | |

| Bin | CIE x | CIE y |
|-----------------------------|--------|--------|
| 60C | 0.3177 | 0.3277 |
| | 0.3249 | 0.3344 |
| | 0.3253 | 0.3266 |
| | 0.3185 | 0.3203 |
| Reference Range: 5850~6240K | | |

| Bin | CIE x | CIE y |
|-----------------------------|--------|--------|
| 60D | 0.3185 | 0.3203 |
| | 0.3253 | 0.3266 |
| | 0.3256 | 0.3191 |
| | 0.3192 | 0.3131 |
| Reference Range: 5850~6240K | | |

| Bin | CIE x | CIE y |
|-----------------------------|--------|--------|
| 56A | 0.3242 | 0.3506 |
| | 0.3325 | 0.3579 |
| | 0.3325 | 0.3493 |
| | 0.3246 | 0.3424 |
| Reference Range: 5500~5850K | | |

| Bin | CIE x | CIE y |
|-----------------------------|--------|--------|
| 56B | 0.3246 | 0.3424 |
| | 0.3325 | 0.3493 |
| | 0.3324 | 0.3410 |
| | 0.3249 | 0.3344 |
| Reference Range: 5500~5850K | | |

| Bin | CIE x | CIE y |
|-----------------------------|--------|--------|
| 56C | 0.3249 | 0.3344 |
| | 0.3324 | 0.3410 |
| | 0.3323 | 0.3329 |
| | 0.3253 | 0.3266 |
| Reference Range: 5500~5850K | | |

| Bin | CIE x | CIE y |
|-----------------------------|--------|--------|
| 56D | 0.3253 | 0.3266 |
| | 0.3323 | 0.3329 |
| | 0.3323 | 0.3251 |
| | 0.3256 | 0.3191 |
| Reference Range: 5500~5850K | | |

| Bin | CIE x | CIE y |
|-----------------------------|--------|--------|
| 53A | 0.3325 | 0.3579 |
| | 0.3412 | 0.3652 |
| | 0.3406 | 0.3562 |
| | 0.3325 | 0.3493 |
| Reference Range: 5180~5500K | | |

| Bin | CIE x | CIE y |
|-----------------------------|--------|--------|
| 53B | 0.3325 | 0.3493 |
| | 0.3406 | 0.3562 |
| | 0.3401 | 0.3476 |
| | 0.3324 | 0.3410 |
| Reference Range: 5180~5500K | | |

| Bin | CIE x | CIE y |
|-----------------------------|--------|--------|
| 53C | 0.3324 | 0.3410 |
| | 0.3401 | 0.3476 |
| | 0.3396 | 0.3392 |
| | 0.3323 | 0.3329 |
| Reference Range: 5180~5500K | | |

| Bin | CIE x | CIE y |
|-----------------------------|--------|--------|
| 53D | 0.3323 | 0.3329 |
| | 0.3396 | 0.3392 |
| | 0.3392 | 0.3310 |
| | 0.3323 | 0.3251 |
| Reference Range: 5180~5500K | | |

Forward Voltage Bins

| Bin code | Forward Voltage [V] |
|----------|---------------------|
| 10 | 1.00 |
| 12 | 1.25 |
| 15 | 1.50 |
| 17 | 1.75 |
| 20 | 2.00 |
| 22 | 2.25 |
| 25 | 2.50 |
| 27 | 2.75 |
| 30 | 3.00 |
| 32 | 3.25 |
| 35 | 3.50 |
| 37 | 3.75 |
| 40 | 4.00 |
| 42 | 4.25 |
| 45 | 4.50 |
| 47 | 4.75 |
| 50 | 5.00 |
| 52 | 5.25 |
| 55 | 5.50 |
| 57 | 5.75 |
| 60 | 6.00 |
| 62 | 6.25 |
| 65 | 6.50 |
| 67 | 6.75 |
| 70 | 7.00 |

Notes:

1. Forward voltage measurement tolerance: $\pm 0.05V$.
2. Forward voltage bins are defined at $I_F = 30mA$ operation.

5. Part Number

67-31-C70301H-AM

Part number is designated with below details.

67-31 = Product family name.

C = Color ^[1]

7 = CRI (0=N/A; >70%=7; >80%=8; >90%=9)

030 = Test current [mA]

0 = Lead Frame Type (0=Ag; 1=Au)

H = Brightness Level (H=High; L=Low)

AM = Automotive application

Note

^[1] Color :

| Symbol | Description |
|--------|--------------------------|
| C | Cool White |
| N | Neutral White |
| W | Warm White |
| PA | Phosphor Converted Amber |
| PR | Phosphor Converted Red |
| UB | Blue |
| IB | Ice Blue |
| SB | Sky Blue |
| UG | Green |
| UY | Yellow |
| UA | Amber |
| UR | Red |
| SR | Super Red |
| RGB | RGB-Color |

6. Ordering Information

67-31-C70300H-ABCDEFGHIJKLMNO-PQ-AM

| Part Number of the 67-31 | Order Code |
|--------------------------|------------------------------------|
| 67-31-C70301H-AM | 67-31-C70301H-53A64DBBCB2737-2T-AM |

Order code contains information with below details :

ABCDEF = min/max wavelength or CCT

GHJK = min./max. luminous flux in [lm] or luminous intensity in [mcd]

LMNO = min./max. forward voltage

PQ = internal code

AM = Automotive Application

7. Reliability Test

| No. | Test Items | Test Condition | Test sample Q'ty | Reference Specification |
|-----|--|--|------------------|-----------------------------------|
| 1 | PreCon | -40-60deg, Curing 125deg, 24h / 60deg, 60%RH, 40hrs, Reflow 3 times | 693, 3 lots | AEC-Q101 Rev. C |
| 2 | Solderability | 1) For SnPb, 16HR@ 155°C, then Solder dip 235°C, 3 Sec, 1 time | 30, 3 lots | AEC-Q101 Rev. C |
| 3 | Resistance to Solder Heat | Tsol=260deg, Time > 255 deg = 30sec, Time > 217 deg = 90 sec, 3 times | 30 | AEC-Q101 Rev. C GQAS from VDO |
| 4 | Temperature Cycle | 100deg to -40deg, Dwell time = 15min. Transfer 5 minutes, air-to-air 1000 cycles, test at 0, 168, 500, 1000 | 231, 3 lots | AEC-Q101 Rev. C |
| 5 | High Temp. / Humidity Operational Life | 85deg, RH=85%, 1000h, I rated, 1000h, test at 0, 168, 500, 1000h | 77 | JIS C7021 Method B-11 Condition C |
| 6 | Humidity with Reverse Bias | 85deg, 85%RH, -5V, 1000h, test at 0, 168, 500, 1000h | 231, 3 lots | Everlight internal reference |
| 7 | Low Temperature Storage | -40deg, 1000h, test at 0, 168, 500, 1000 hr | 77 | JIS C 7021 Method B-10 |
| 8 | High Temperature Storage | 110deg, 1000h, test at 0, 168, 500, 1000h | 77 | JIS C 7021 Method B-10 |
| 9 | Room temperature life test-1 | Ta=25°C, 100hrs, I max, test at 0, 168, 500, 1000h | 77 | Everlight internal reference |
| 10 | High temperature life test | Ta=100deg, 1000h, I rated, test at 0, 168, 500, 1000h | 77 | Everlight internal reference |
| 11 | Low temperature life test | Ta=-40deg, 1000h, I max, test at 0, 168, 500, 1000h | 77 | Everlight internal reference |
| 12 | Power Temperature Cycle (PTC) | -40 °C ~ 100 °C, I rated, Dwell/transfer time=15mins, 2 mins on/off 15,000 cycles, test at 0, 2500, 7,500, 15,000 power cycles | 231, 3 lots | AEC-Q101 Rev. C |
| 13 | ESD Human Body Model | 2000V, 3 times, interval: 0.5sec, 40%RH | 30 | AEC-Q101 Rev. C |
| 14 | ESD Machine Model | 200V, 3 times, interval: 0.5sec, 40%RH | 30 | AEC-Q101 Rev. C |

Failure Criteria:

Luminous Flux ; +/-20%, Forward Voltage ; +/-10%, Color Coordinates x,y ; +/-0.01, Color wavelength; +/- 0.5nm °

8. Mechanical Dimension

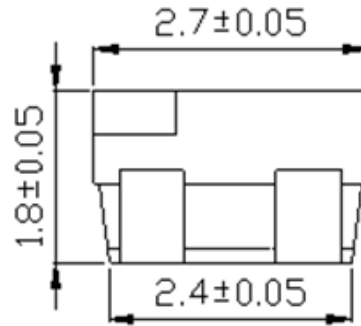
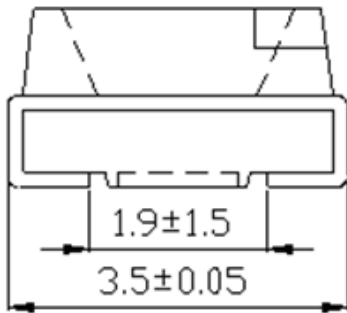
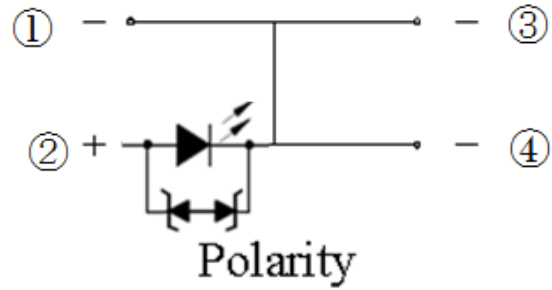
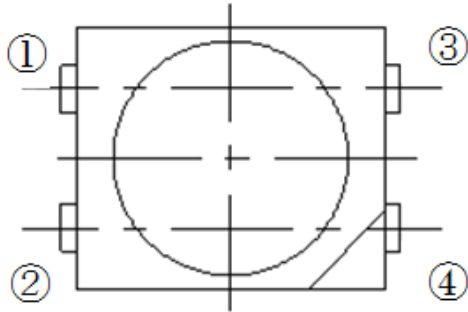

Notes:

1. Dimensions are in millimeters.
2. Tolerances unless mentioned are ± 0.1 mm.

9. Recommended Soldering Pad

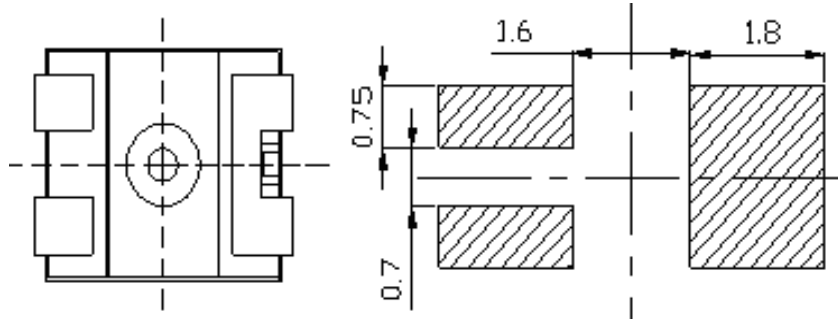

10. Reflow Soldering Profile

Soldering Condition (Reference: IPC/JEDEC J-STD-020D)

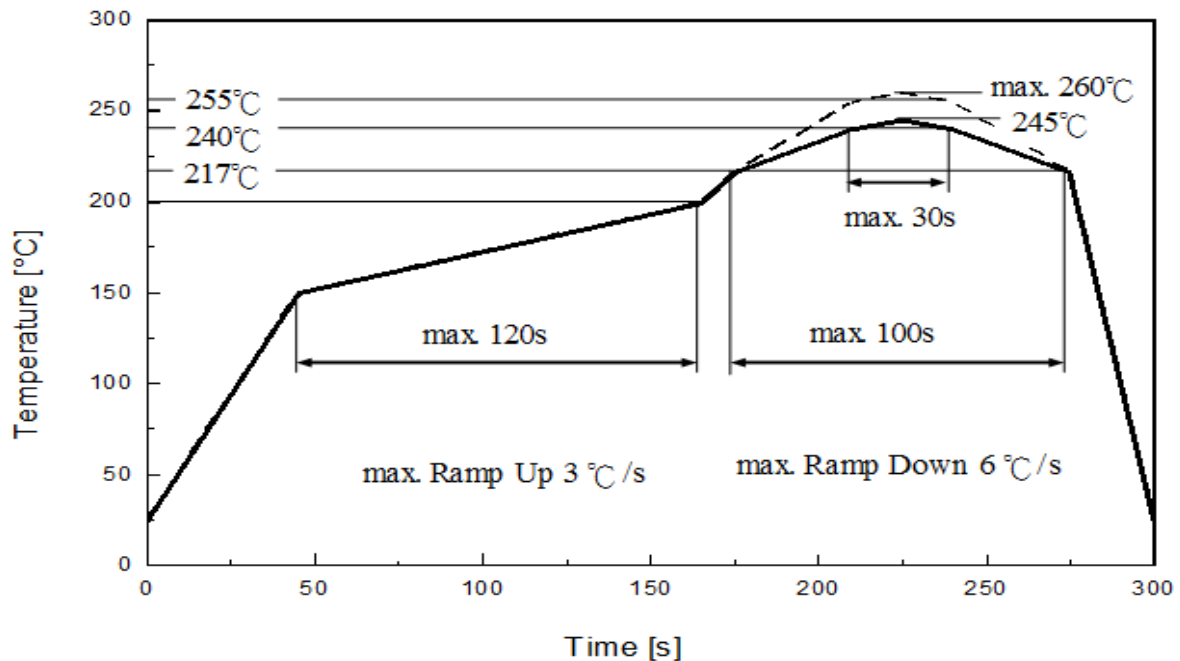

| Profile Feature | Pb-Free Assembly | Unit |
|--|------------------|---------|
| | Recommendation | |
| Ramp-up rate to preheat 25 °C to 150 °C | 3 | °C /sec |
| Time of soaking zone 150 °C to 200 °C | 120 | sec |
| Ramp-up rate to peak | 3 | °C /sec |
| Liquefied temperature | 217 | °C |
| Time above liquefied temperature | 100 | sec |
| Peak temperature (max.) | 260 | °C |
| Time within 5°C of the specified peak temperature | 30 | sec |
| Ramp-down Rate (max.) | 6 | °C /sec |

11. Packaging Information

• Product Labeling



- CPN : Customer's Product Number
- P/N : Everlight Part Number
- QTY : Packing Quantity
- CAT : Luminous Flux (Brightness) Bin
- HUE : Color Bin
- REF : Forward Voltage Bin
- LOT No : Lot Number

• Packing: Loaded Quantity 2000 pcs Per Reel

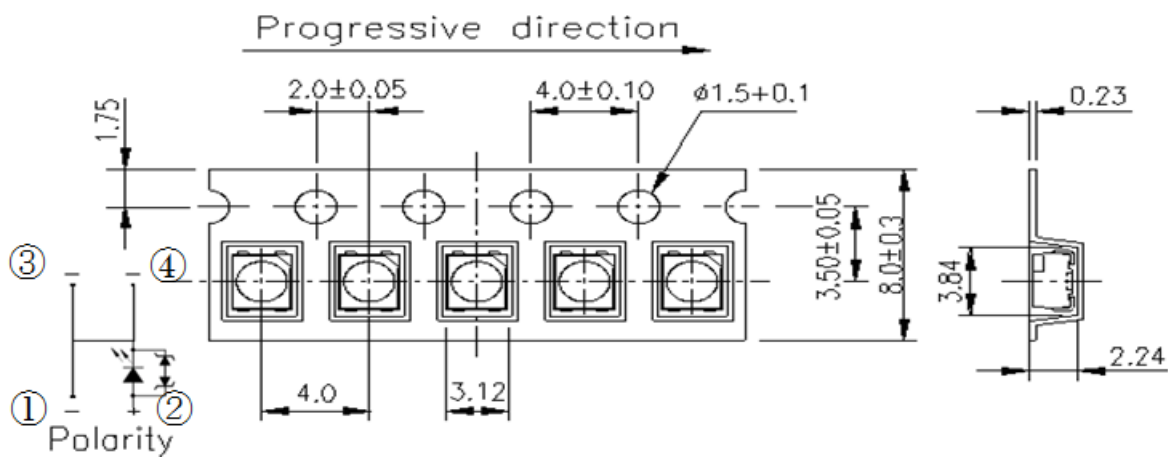

Notes:

1. Dimensions are in millimeters.
2. Tolerances for fixed dimensions are $\pm 0.2\text{mm}$.

● Reel Dimensions

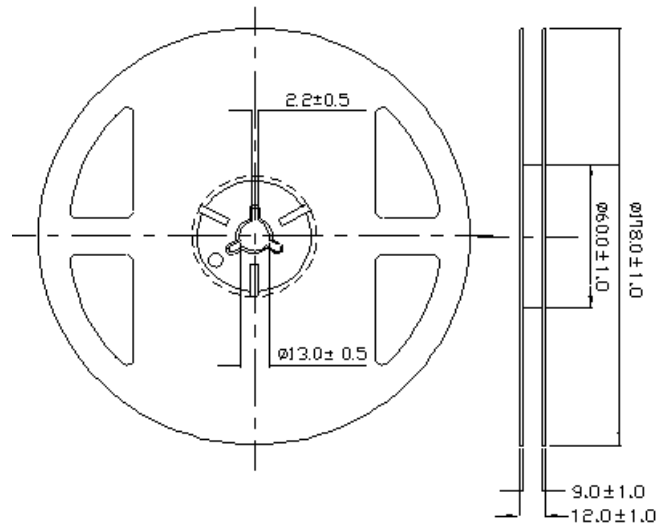

Notes:

1. Dimensions are in millimeters.
2. Tolerances unless mentioned are ± 0.2 mm.

● Moisture Resistant Packing Process

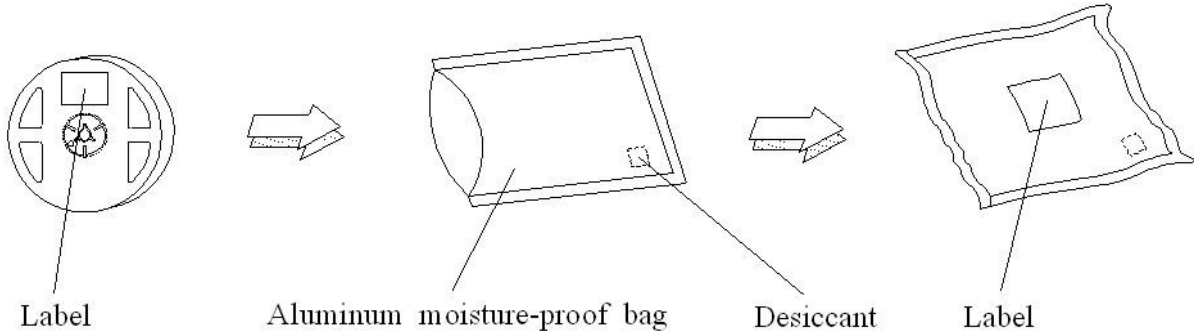

Notes:

1. Dimensions are in millimeters.
2. Tolerances unless mentioned are ± 0.2 mm.

12. Precaution for Use

1. Over-current-proof
Customer must apply resistors for protection; otherwise slight voltage shift will cause big current change (burn out will happen).
2. Assemblies
Do not stack assemblies containing LEDs to prevent damage to the optical surface of LEDs. Forces applied to the optical surface may result in the surface being damaged.
3. Soldering Condition
 - 3.1 When soldering, do not put stress on the LEDs during heating.
 - 3.2 After soldering, do not warp the circuit board.
4. Soldering Iron
Each terminal is to go to the tip of soldering iron temperature less than 350°C for 3 seconds within once in less than the soldering iron capacity 25W. Leave two seconds and more intervals, and do soldering of each terminal. Be careful because the damage of the product is often started at the time of the hand solder.
5. Repairing
Repair should not be done after the LEDs have been soldered. When repairing is unavoidable, a double-head soldering iron should be used (as below figure). It should be confirmed beforehand whether the characteristics of the LEDs will or will not be damaged by repairing.

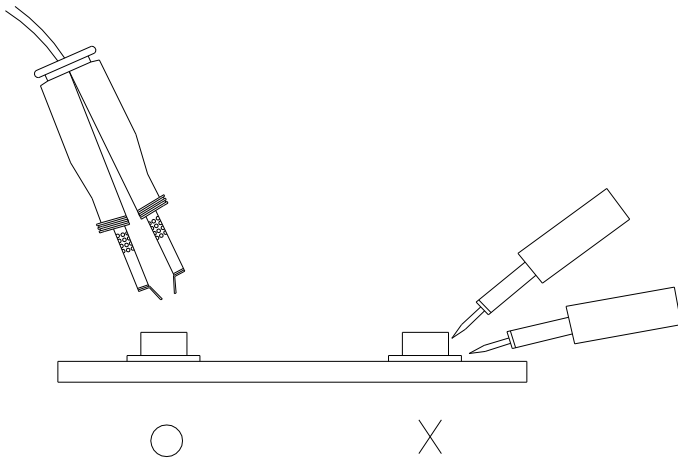

Revision History

Current version: Sep.07.2016

Issue No:

Version: 1.0

Created by: Mark Lai

| Rev. | Subjects (major change in previous version) | Modified date |
|------|---|---------------|
| 1.0 | Standard data sheet | 2016/09/07 |
| | | |
| | | |
| | | |
| | | |
| | | |