

Proximity Sensor with I²C Interface PM-8D23-20-DF8/TR8

Feature

- PS
 - low power consumption
 - narrow band IR spectrum
 - programmable IRED intensity
 - programmable periodic sleep time between each measurement
- Interrupts
 - adjustable interrupt persistency
- Green Power
 - less than 10μA DC supply current during sleep time
 - less than 0.1μA supply current when powered down
- Easy to Use
 - SMBus Compatible I²C interface
 - auto register addressing
 - temperature compensation
 - interrupt pin and flags
- Wide Operating Voltage Range
 - 1.7V to 3.6V supply for I²C interface
 - 2.3V to 3.6V sensor power supply
 - I²C address selection (bonding optional)
- Wide Operating temperature Range
 - 40°C to 85°C ambient temperature
- Size
 - 3.94mm (L) x2.36mm (W) x1.35mm (H)
- The product itself will remain within RoHS compliant version
- Compliance with EU REACH
- Compliance Halogen Free(Br < 900ppm, Cl < 900ppm, Br+Cl < 1500ppm)

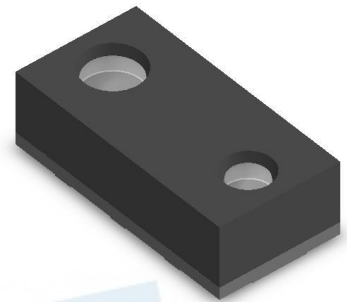

General Description

The PM-8D23-20-DF8/TR8 integrates a proximity sensor (PS), an infrared emitting diode (IRED) driver and an SMBus compatible I²C interface into one chip. The fast I²C interface (up to 750 kHz) is for easy connection to a microcontroller or embedded controller. A flexible interrupt scheme is provided for minimal microcontroller utilization. The PM-8D23-20-DF8/TR8 is featuring low power operation, most suitable for battery powered apparatus.

The proximity sensor (PS) employs a narrow-band, multi-layer optical coating to suppress most infrared background. Synchronized with the built-in IRED driver, the proximity sensing circuitry adopts track-and-hold (T&H) and correlated double sampling (CDS) techniques to reject non-synchronized infrared signals and electrical DC offset. Each proximity measurement takes about 0.8mS, and various sleep-time in between can be programmed through I²C interface to reduce overall power consumption.

The PM-8D23-20-DF8/TR8 provides a separate pin for level-style interrupt which simplifies and improves system efficiency by eliminating the need to poll a sensor for PS readings. An interrupt is generated when the PS reading exceeds the upper threshold. In addition, a programmable interrupt persistence feature allows the user to determine how many consecutive exceeded readings are necessary to trigger an interrupt. Interrupt threshold and persistence settings are configurable through I²C interface.

Applications

- Display and keypad dimming adjustment and proximity sensing for:
 - Mobile Devices: smart phone, PDA, GPS
 - Computing Devices: laptop PC, notebook
 - Consumer Devices: LCD-TV, digital picture frame, digital camera

Package Dimensions

Top View

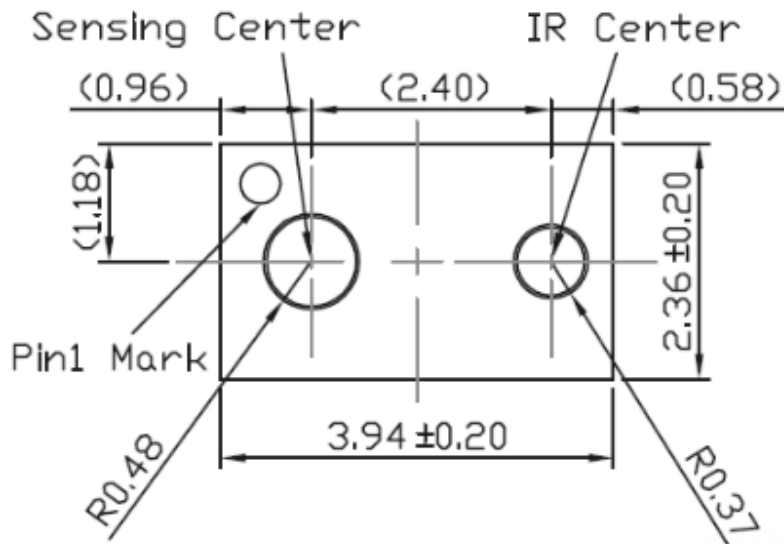

Side View

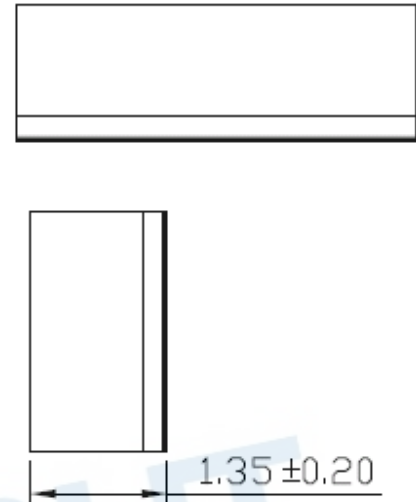

Bottom View

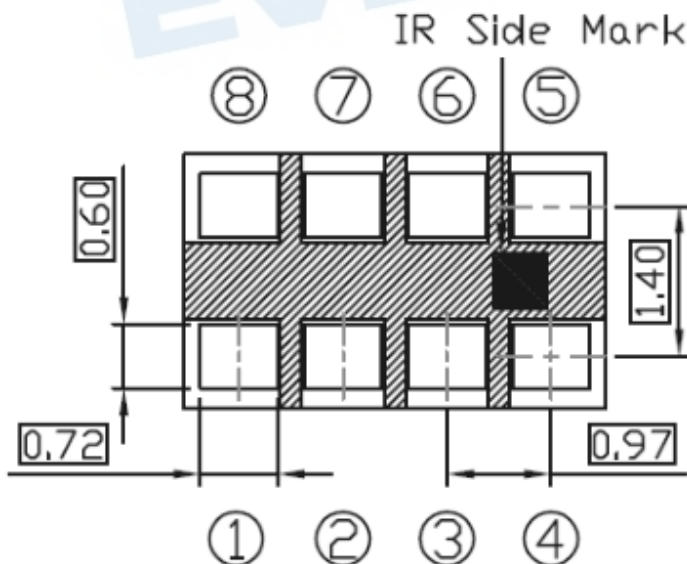

- | | |
|--------|------------|
| ① SDA | ⑤ LEDA |
| ② INT | ⑥ GND/ADDR |
| ③ IRDR | ⑦ SCL |
| ④ LEDK | ⑧ VDD |

Unit: mm
Tolerances: ± 0.2mm

PCB Layout Footprint

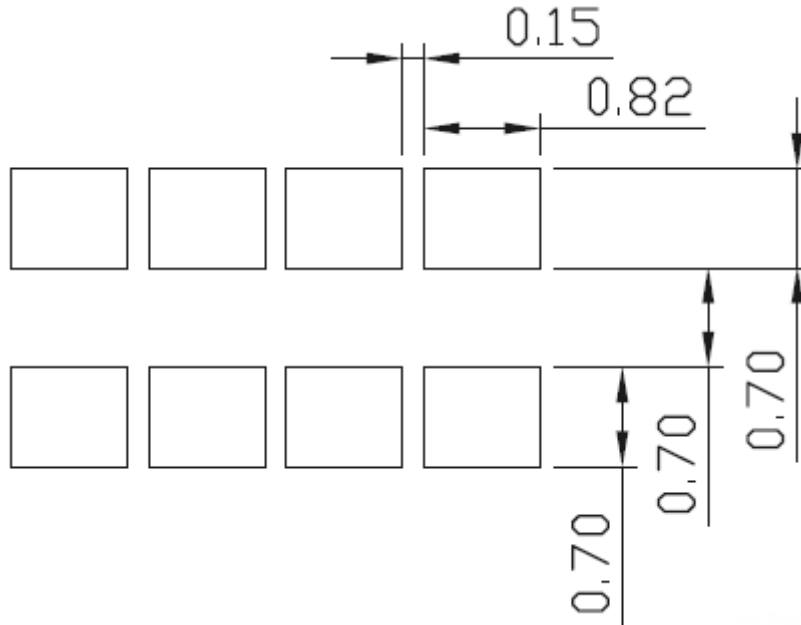

Pin Description

Pin No.	Pin name	Pin function
1	SDA	I2C serial data line
2	INT	Interrupt pin: LO for interrupt alarming. The INT pin is an open drain
3	IRDR	IR LED driver pin connecting to the cathode of the external IR LED
4	LEDK	Cathode of the embedded IR LED, connect to IRDR pin
5	LEDA	Anode of the embedded IR LED, connect to power
6	GND	Ground: The thermal pad is also connected to the GND pin
7	SCL	I2C serial clock line
8	VDD	Power supply voltage: 2.3V ~ 3.6V

Block Diagram

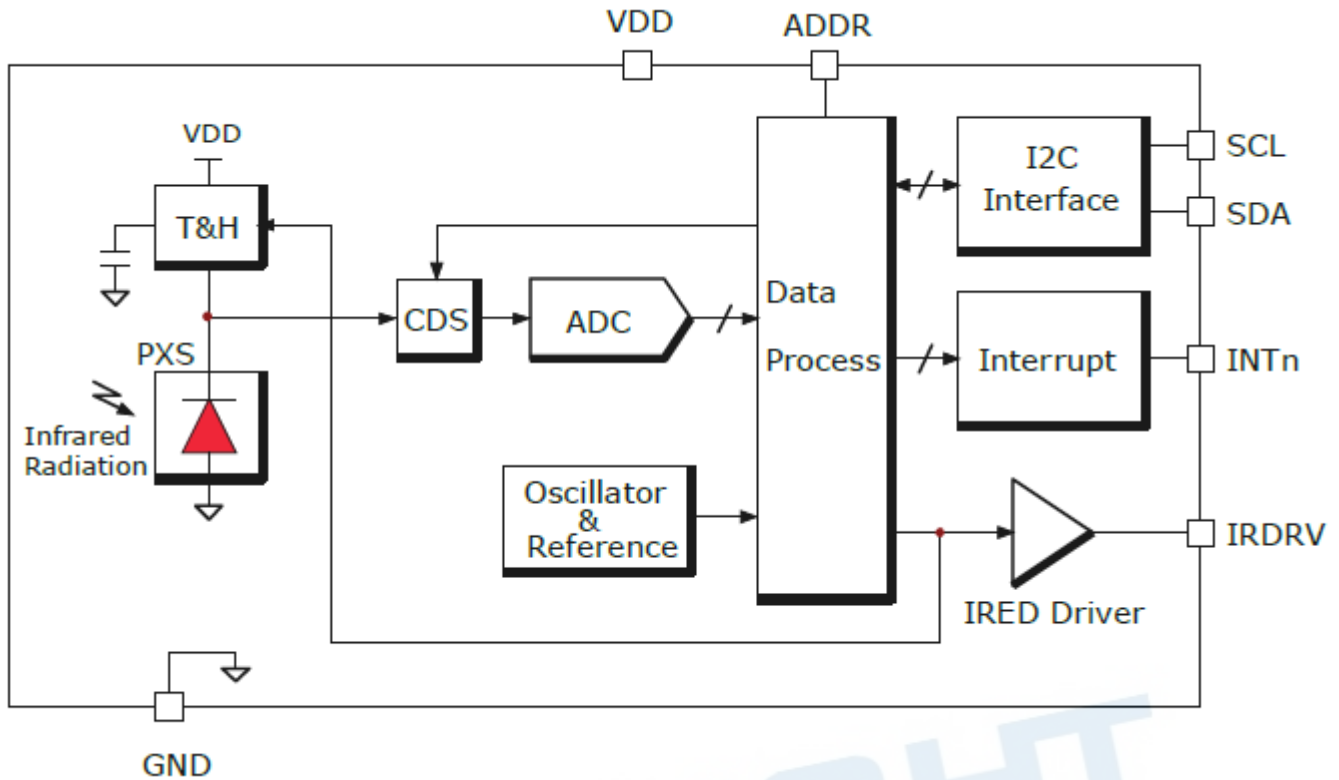

Typical Application Circuit

A typical application for the PM-8D23-20-DF8/TR8 is shown in Figure 1. The PM-8D23-20-DF8/TR8's I²C address is 0x45 when ADDR is tied to GND. The device can be tied onto a system's I²C bus together with other I²C compliant devices.

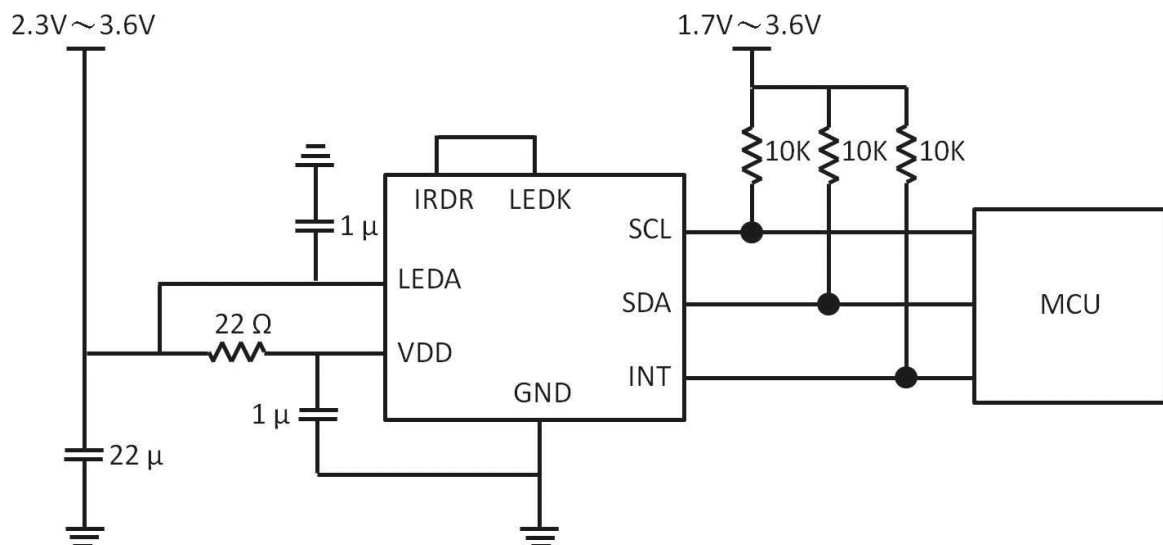

Figure 1. PM-8D23-20-DF8/TR8 typical application circuit

Layout Considerations

The PM-8D23-20-DF8/TR8 is relatively insensitive to layout. Like other I²C devices, it is intended to provide excellent performance even in significantly noisy environments. There are only a few considerations that will ensure best performance. Route the supply and I²C traces as far as possible from all sources of noise. A 0.1 μ F and 1 μ F power supply decoupling capacitors need to be placed close to the device.

Absolute Maximum Ratings (T_A=+25°C)

Parameter	Rating	Unit
VDD supply voltage	4.0	V
I ² C bus voltage (SCL, SDA)	-0.5 to 4.0	V
I ² C bus current (SCL, SDA)	< 10	mA
IRDRV pin voltage	5.5	V
ADDR pin voltage	-0.5 to VDD+0.5	V
INTn pin voltage	-0.5 to 4.0	V
INTn pin current	< 10	mA
ESD Rating (HBM)	8	KV

Caution: Do not operate at or near the maximum ratings listed for extended periods of time. Exposure to such conditions may adversely impact product reliability and result in failures not covered by warranty.

Important Note: All parameters having Min/Max specifications are guaranteed. Typical values are information purposes only. Unless otherwise noted, all tests are the specified temperature and pulsed tests, therefore: T_J=T_C=T_A

Electrical Characteristics (VDD=3.0V, T_A=+25°C)

Parameter	Descriptions	Conditions	Min.	Typ.	Max.	Unit
V _{DD}	Power supply range		2.3	3.0	3.6	V
I _{DD_OFF}	Supply current when PS is disabled	PS_EN = 0	-	0.01	0.1	μA
I _{DD(PK)}	Peak supply current while measurement is talking place	PS_EN = 1 (not including I _{RED} driving current)	-	85		μA
I _{DD(SLEEP)}	Supply current during sleep time	PS_EN = 1 (not including I _{RED} driving current)	-	10	-	μA
Count _{PS_DK}	PS measurement w/o object in path	PS_IR_Pulse=2.Open view (no glass) and no reflective object above the module.	0	10	-	counts
Count _{PS_FS}	Full scale of PS output		-	-	255	counts
Count _{PS_1}	PS measurement IR_PULSE=0	850nm IRED, fixed distance	20	25	30	counts
Count _{PS_2}	PS measurement IR_PULSE=1	850nm IRED, fixed distance	40	50	60	counts
Count _{PS_3}	PS measurement IR_PULSE=2	850nm IRED, fixed distance	80	100	120	counts
Count _{PS_4}	PS measurement IR_PULSE=3	850nm IRED, fixed distance	160	200	240	counts
t _r	Rise time for IRDR sink current	R _{LOAD} = 15Ω at IRDR, 20% to 80%	-	0.5	-	μS
t _f	Full time for IRDR sink current	R _{LOAD} = 15Ω at IRDR, 80% to 20%	-	0.5	-	μS
I _{IRDRV_0}	IRDRV driving current (sink)	V _{IRDRV} = 0.5V	85	100	115	mA
I _{IRDRV_LEAK}	IRDRV leakage current	PS_EN = 0, VDD = 3.6V		0.01	0.1	μA
V _{IRDRV}	Sustained voltage on IRDRV		-	-	3.6	V
f _{I2C}	I ² C clock rate		0	-	750	KHz
V _{I2C}	Supply voltage range for I ² C interface		1.7	-	3.6	V
V _{IL}	SCL and SDA input low voltage		-	-	0.55	V
V _{IH}	SCL and SDA input high voltage		1.25	-	-	V
I _{SDA}	SDA current sinking capability	V _{OL} = 0.4V	2.7	5	-	mA
I _{INTn}	INTn current sinking capability	V _{OL} = 0.4V	2.7	5	-	mA
SR_VDD	Power-up slew rate	VDD rising edge between 0.4V and 2.3V	0.5	-	-	V/ms

I²C Electrical Specifications (VDD=3.0V, T_A=+25°C)

Parameter	Descriptions	Conditions	Min.	Typ.	Max.	Unit
V _{I²C}	Supply voltage range for I ² C interface		1.7	-	3.6	V
f _{SCL}	SCL clock frequency		-	-	750	KHz
V _{IL}	Low level input voltage of SCL and SDA		-	-	0.55	V
V _{IH}	High level input voltage of SCL and SDA		1.25	-	-	V
V _{hys}	Hysteresis of Schmitt trigger input		0.05V _{DD}	-	-	V
V _{OL}	Low-level output voltage (open-drain) at 4mA sink current		-	-	0.4	V
I _i	Input leakage for each SDA, SCL		-10	-	10	μA
t _{SP}	Pulse width of spikes that must be suppressed by the input filter		-	-	50	nS
t _{AA}	SCL falling edge to SDA output data valid		-	-	0.9	μS
C _i	Capacitance for each SDA and SCL pin		-	-	10	pF
t _{HD:STA}	Hold time (repeated) START condition		0.6	-	-	μS
t _{LOW}	Low period of the SCL clock		1.3	-	-	μS
t _{HIGH}	High period of the SCL clock		0.6	-	-	μS
t _{SU:STA}	Set-up time for a repeated START condition		0.6	-	-	μS
t _{HD:DAT}	Data hold time		30	-	-	nS
t _{SU:DAT}	Data set-up time		100	-	-	nS
t _{SU:STO}	Set-up time for STOP condition		0.6	-	-	μS
t _{BUF}	Bus free time between a STOP and START condition		1.3	-	-	nS
T _r	Rise time of both SDA and SCL	R _{pull-up} = 10KΩ, C _b = 10pF	-	95	-	nS
T _f	Fall time of both SDA and SCL	R _{pull-up} = 10KΩ, C _b = 10pF	-	25	-	nS
C _b	Capacitive load for each bus line		-	-	0.4	nF
R _{pull-up}	SDA and SCL system bus pull-up resistor	Maximum is determined by t _r and t _f	-	10	-	KΩ
t _{VD:DAT}	Data valid time		-	-	0.9	μS
t _{VD:ACK}	Data valid to acknowledge time		-	-	0.9	μS
V _{nL}	Noise margin at the LOW level		0.1V _{DD}	-	-	V
V _{nH}	Noise margin at the HIGH level		0.2V _{DD}	-	-	V

Note: The I²C bus protocol was developed by Philips (now NXP). For a complete description of the I²C protocol, please review the NXP I²C design specification at <http://www.i2c-bus.org/references/>.

I²C Timing Diagram

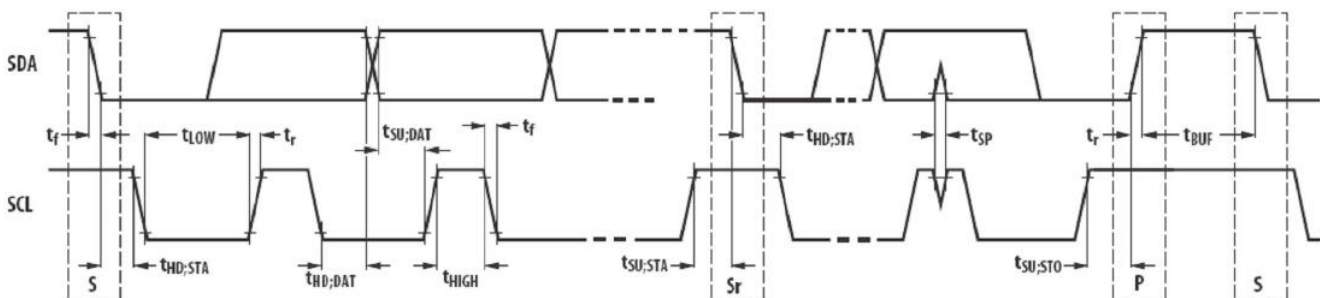

Figure 2. I²C Timing Diagram

Register Map

There are six 8-bit registers accessible via I²C. Registers 0x01 and 0x02 define the operation mode of the device. Register 0x03 and 0x04 store the PS thresholds which trigger interrupt events. Register 0x05 store the PS readings.

REG ADDR	REG NAME	BIT								Default	
		7	6	5	4	3	2	1	0		
0x00	Product ID	Product ID Code for Communication Link Test								0x24	
0x01	CONFIGURE	PS_EN	SLEEP_TIME			IR_PULSE		PERST		0x00	
0x02	INTERRUPT	PS_FLAG	Write 0								0x00
0x03	PS_LT	PS_LT[7:0]								0x00	
0x04	PS_HT	PS_HT[7:0]								0xFF	
0x05	PS_Reading	PS_DATA[7:0]								0x00	

Register 0x01 (Configure)

Bit #	Access	Default	Name	Function / Operation
7	RW	0x00	PS_EN (PS Enable)	When = 0, proximity sensing is disabled. When = 1, proximity sensing is enable. Proximity reading will be ready 2ms after this bit is set high
6:4	RW	0x00	SLEEP_TIME (PS Sleep)	For bits 6:4 = (see the following) 111; sleep time between PS IR LED pulse is 0.0ms (run continuously) 110; sleep time between PS IR LED pulse is 12.5ms 101; sleep time between PS IR LED pulse is 50ms 100; sleep time between PS IR LED pulse is 75ms 011; sleep time between PS IR LED pulse is 100ms 010; sleep time between PS IR LED pulse is 200ms 001; sleep time between PS IR LED pulse is 400ms 000; sleep time between PS IR LED pulse is 800ms
3:2	RW	0x00	IR_PULSE	For bits 3:2 = (see the following) 00: one unit 01: two units 10: four units 11: eight units
1:0	RW	0x00	PERST	For bits 1:0 = (see the following) 00: set INT_FLAG if 1 reading trips the threshold 01: set INT_FLAG if 4 reading trips the threshold 10: set INT_FLAG if 8 reading trips the threshold 11: set INT_FLAG if 16 reading trips the threshold

Register 0x02 (Interrupt)

Bit #	Access	Default	Name	Function / Operation
7	RW	0x00	INT_FLAG (PS Flag)	When = 1, PS interrupt event occurred. Reset when PS reading is below the low threshold or by a write-operation on Register 0x02

Register 0x03 (PS_LT)

Bit #	Access	Default	Name	Function / Operation
7:0	RW	0x00	PS_LT (PS Threshold)	8-bit low interrupt threshold

Register 0x04 (PS_HT)

Bit #	Access	Default	Name	Function / Operation
7:0	RW	0xFF	PS_HT (PS Threshold)	8-bit high interrupt threshold

Register 0x08 (PS_DATA)

Bit #	Access	Default	Name	Function / Operation
7:0	RO	0x00	PS_DATA (Proximity Data)	8-bit PS reading

Principles of Operation

I²C Read/Write Register Data

The PM-8D23-20-DF8/TR8's I²C slave address is 0x45 when ADDR pad is tied to GND. Below picture detail the protocol of writing or reading the register data inside the PM-8D23-20-DF8/TR8.

- A : Acknowledge (0)
- NA : Not Acknowledged (1)
- P : Stop Condition
- R : Read (1)
- W : Write (0)
- S : Start Condition
- Sr : Repeat Start
- ... : Continuation of Protocol
- : Mater to Slave
- : Slave to Mater

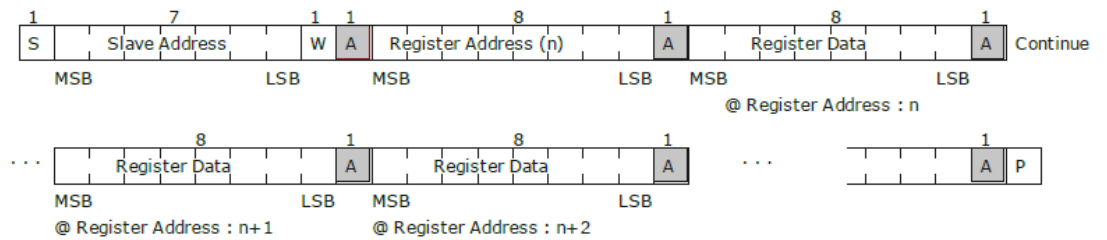

Figure 3. I²C Write-Register-Data Protocol

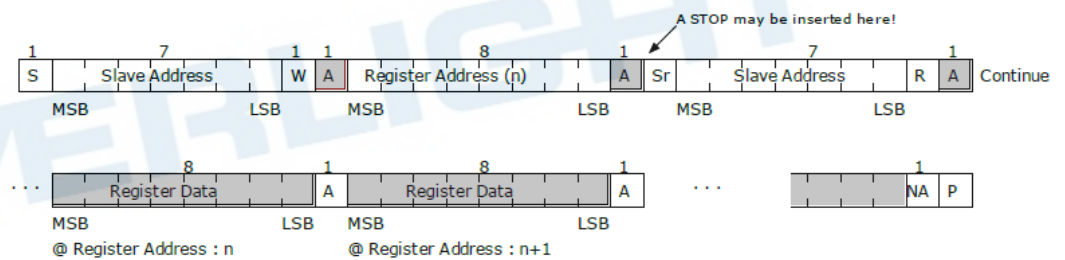

Figure 4. I²C Read-Register-Data Protocol

Proximity Sensing

As illustrated in below picture, an infrared emitter (IRED), driven by the PS circuitry, emits synchronized infrared pulsed. The object on the light path reflects the infrared radiation pulsed that are detected by the PS. With a narrow band optical coating on the proximity sensor, the PS only receives the infrared around 850nm wavelength, rejecting most ambient light interference. By using the track-and hold (T&H) and correlated double sample (CDS) techniques, the PS is capable of measuring the intensity of reflected infrared pulsed. Proper infrared baffle may be required due to the crosstalk from IRED to PS.

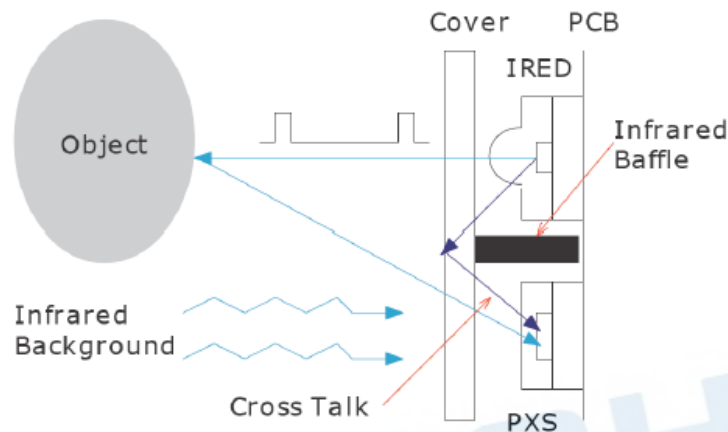

Figure 5. Proximity Sensing

When the PM-8D23-20-DF8/TR8's proximity sensing is enable (PS_EN=1), the PS takes the time of (PULSE_NUM+1) x 0.5mS to take one measurement. The pulsed driving current of the IRED is 100mA in amplitude. The sleep time (t_{sleep}) between proximity measurements is determined by setting the PS_SLP. bits.

$$\begin{aligned}
 &100\text{mA} \times 50\mu\text{S} / (t_{\text{sleep}} + 0.4\text{mS}) , \text{ when PULSE_NUM}=0 ; \\
 &100\text{mA} \times 100\mu\text{S} / (t_{\text{sleep}} + 0.4\text{mS}) , \text{ when PULSE_NUM}=1 ; \\
 &100\text{mA} \times 200\mu\text{S} / (t_{\text{sleep}} + 0.8\text{mS}) , \text{ when PULSE_NUM}=2 ; \text{ and} \\
 &100\text{mA} \times 400\mu\text{S} / (t_{\text{sleep}} + 1.6\text{mS}) , \text{ when PULSE_NUM}=3 .
 \end{aligned}$$

Interrupt Function

Interrupt INT_FLAG is set when the PS reading is more than the high threshold (PS_HT). INT_FLGA is cleared when the PS reading (PS_DAT) is lower than the low threshold (PS_LT), or when a write-operation is done on Register 0x02. To further control when an interrupt occurs, PM-8D23-20-DF8/TR8 provides a persistence filter which allows the user to specify the number of consecutive occurrences of proximity readings tripping over the threshold before an interrupt is generated.

The configuration register (Register 0x01) allows the user to set the proximity persistence (PRST) values. See the configuration register for details on the persistence filter values.

VDD Power-up and Power Supply

Upon power-up, please ensure the slew rate of VDD greater than 0.5V/mS. After power-up, the supply voltage shall NOT drop below 2.0V. Once it happens, please switch off the power, wait more than 1 second, and then power on the device again.

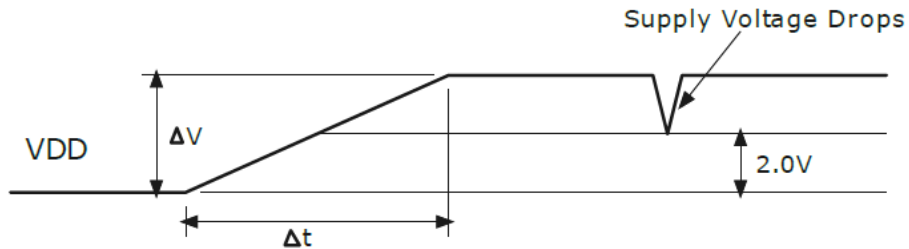

$$\text{Slew Rate} = \frac{\Delta V}{\Delta t} > 0.5V / \text{mS}$$

Figure 6. Waveform of Supply Voltage VDD

Power-Down

To put the PM-8D23-20-DF8/TR8 into a power-down state, the user can set both PXS_EN to 0; or more simply, reset Register 0x01.

Recommended Solder Profile

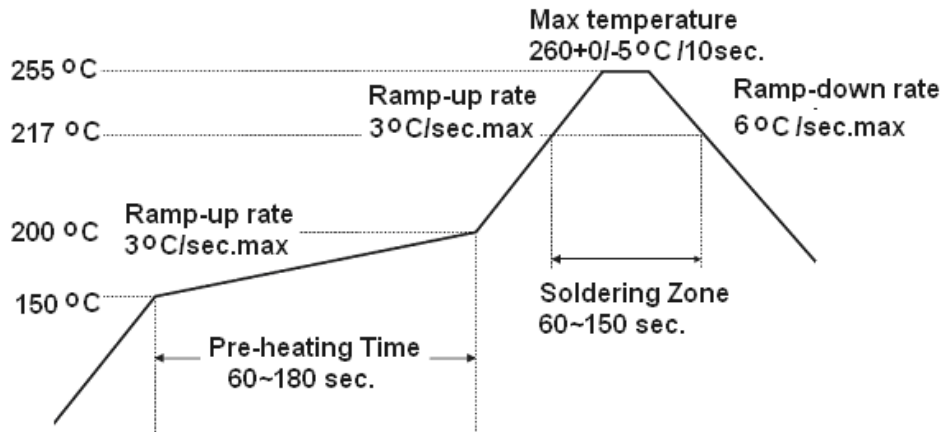

Notice:

1. Reflow soldering should not be done more than two times.
2. When soldering, do not put stress on the devices during heating.
3. After soldering, do not warp the circuit board.

Soldering Iron

Each terminal is to go to the tip of soldering iron temperature less than 350°C for 3 seconds within once in less than the soldering iron capacity 25W. Leave two seconds and more intervals, and do soldering of each terminal. Be careful because the damage of the product is often started at the time of the hand solder.

Repairing

Repair should not be done after the device have been soldered. When repairing is unavoidable, a double-head soldering iron should be used (as below figure). It should be confirmed beforehand whether the characteristics of the device will or will not be damaged by repairing.

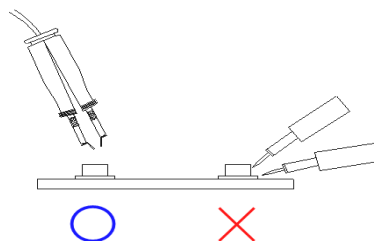

Packing Quantity Specification

2000 PCS/ 1 Reel

Label Format

EVERLIGHT: Company name
 CPN: Customer part number
 P/N: Part number
 QTY: Quantity
 LOT NO: Lot number
 CAT: Category
 HUE: Wavelength
 REF: Reference
 MADE IN XXXXXX : Production Place

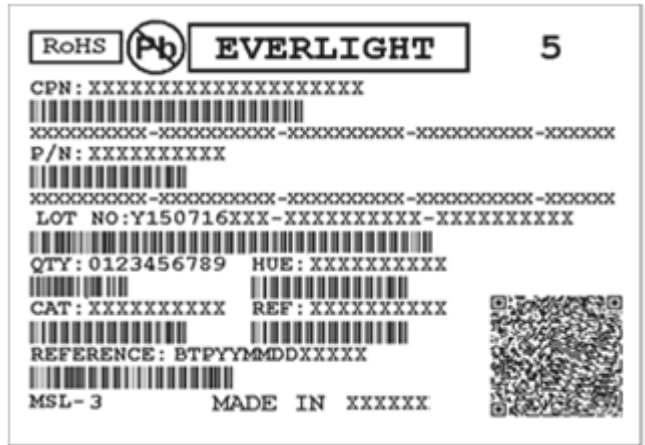

Reel Dimensions

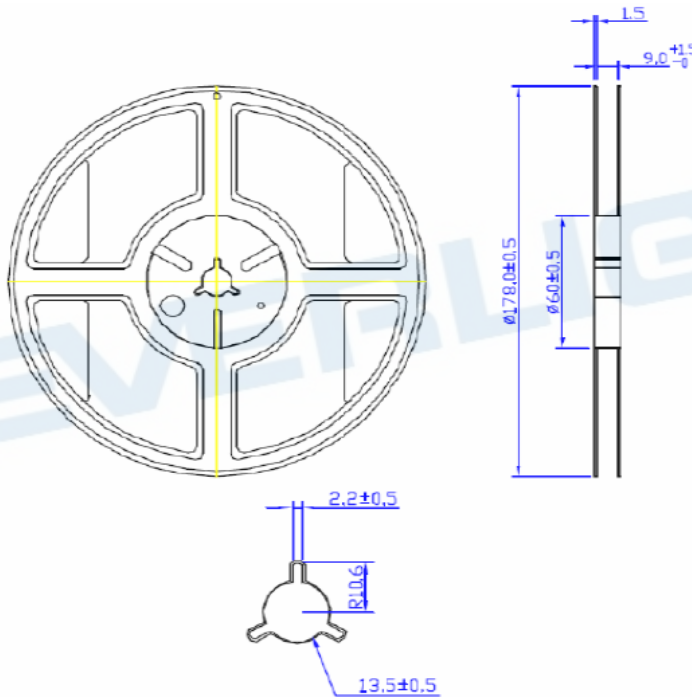

Tape Dimensions

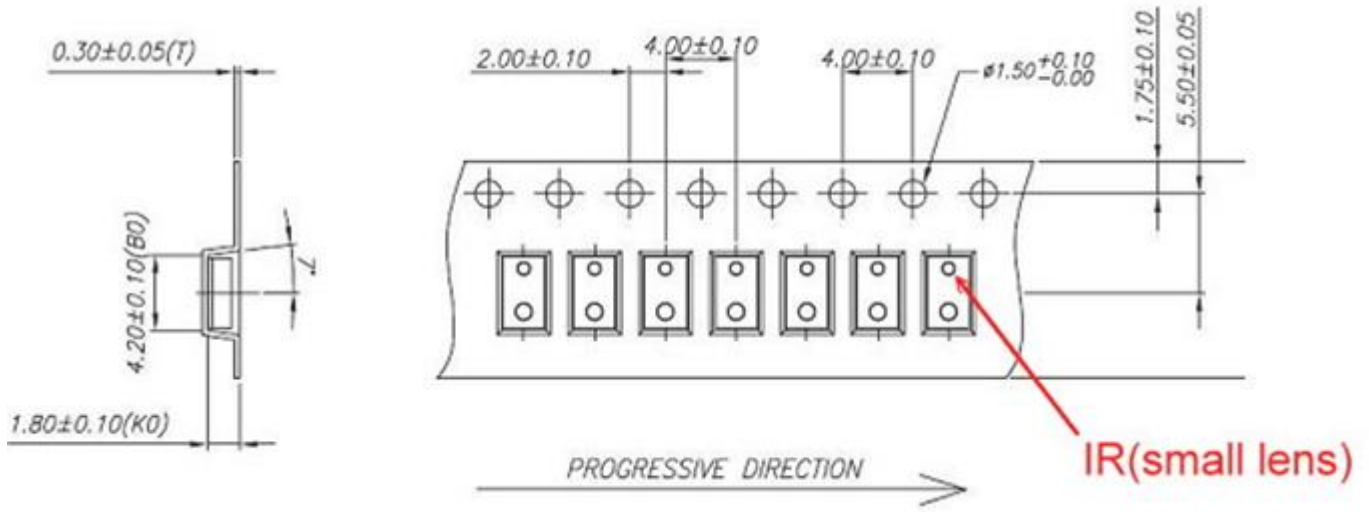

EVERLIGHT

DISCLAIMER

1. EVERLIGHT reserves the right(s) on the adjustment of product material mix for the specification.
2. The product meets EVERLIGHT published specification for a period of twelve (12) months from date of shipment.
3. The graphs shown in this datasheet are representing typical data only and do not show guaranteed values.
4. When using this product, please observe the absolute maximum ratings and the instructions for using outlined in these specification sheets. EVERLIGHT assumes no responsibility for any damage resulting from the use of the product which does not comply with the absolute maximum ratings and the instructions included in these specification sheets.
5. These specification sheets include materials protected under copyright of EVERLIGHT. Reproduction in any form is prohibited without obtaining EVERLIGHT's prior consent.
6. This product is not intended to be used for military, aircraft, automotive, medical, life sustaining or life saving applications or any other application which can result in human injury or death. Please contact authorized Everlight sales agent for special application request.

EVERLIGHT