

GXUAN 1313

36V/6W V3 series

烜



Introduction

Everlight's COB Series is an aluminum substrate based LED achieving high efficiency while maintaining high CRI at Energy Star / ANSI color temperature ranges.

Features

- ◆ High Power COB & High CRI LED
- ◆ Multi-Chip Solution
- ◆ Dimension: 13.5mm x 13.5mm x 1.6 mm
- ◆ Main Parameters: Luminous Flux, Forward Voltage, Chromaticity and Color Rendering Index
- ◆ RoHS compliant
- ◆ Energy Star / ANSI Compliant Binning Structure
- ◆ Typical Viewing Angle: 115°

Applications

- ◆ Replacement Bulb
- ◆ Indoor General Lighting
- ◆ Recessed Can Lighting

Table of Contents

Product Nomenclature	3
Absolute Maximum Ratings	4
PN of the GXUAN 1313 36V/6W V3 series:White LEDs	5
Product Binning:Luminous Flux Bins	6
Product Binning:Warm White Bin Structure	7
Product Binning:Warm White Bin Coordinates	7
Product Binning:Neutral White Bin Structure	8
Product Binning:Neutral White Bin Coordinates	8
Product Binning:Cool White Bin Structure	9
Product Binning:Cool White Bin Coordinates	9
Product Binning:Forward Voltage Bins	10
Mechanical Dimension	11
Pad Configuration	12
Typical Electro-Optical Characteristic Curve	13
Product Labeling	18
Carrier Tray Specification	18
Precautions of Use	19
Revision History	22

EVERLIGHT

Product Nomenclature

The product name is designated as below:

GXUAN1313-CDEFGHJ-KLMNP-QRST

Family name
GXUAN1313

Designation:

CD = lighting color and wavelength^[1]

EF = color bin or CCT bin

G = internal code

HJ = min. luminous flux (lm) or radiation power (mW) performance

KL = forward voltage bin^[2]

M = internal code

NP = power consumption^[3]

Q= internal code

R= Dam Diameter^[4]

S= internal code

T=Type of Package^[5]

Notes

1. Table of lighting color and wavelength

Symbol	Color	CCT range	Color Rendering Index
GT	Cool-White	4745~7050K	>65
KT	Cool-White	4745~7050K	>80
PT	Cool-White	4745~7050K	>90
LM	Warm-White	2580~3710K	>70
	Neutral-White	3710~4745K	
KM	Warm White	2580~3710K	>80
	Neutral-White	3710~4745K	
PM	Warm-White	2580~3710K	>90
	Neutral-White	3710~4745K	

2. Table of forward voltage bin

Symbol	Description
36	36V Input Voltage

3. Power consumption:

Symbol	Description
6	6W

4. Dam Diameter:

Symbol	Description
9	9.0-9.9mm

5. Table of packaging types:

Symbol	Description
T	Tray

Absolute Maximum Ratings

Parameter	Symbol	Ratings	Unit
Max. DC Forward Current (mA) _{[4],[5]}	I_F	360	mA
Max. Pulse Forward Current (mA)	I_P	400	mA
Power Dissipation	P_d	13.8	W
Thermal Resistance	R_{th}	1.0	°C/W
Max. Junction Temperature	T_J	120	°C
Operating Temperature _{[4],[5]}	T_{Opr}	-40 ~ +85	°C
Storage Temperature	T_{Stg}	-40 ~ +85	°C

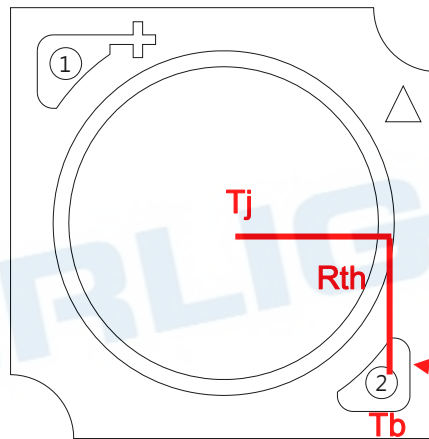

Notes:

1. For optimal performance, Everlight recommends 180mA operation.
2. $t_p \leq 100ms$, Duty cycle = 25%
3. The GXUAN1313 36V/6W V3 series LEDs are not designed for reverse bias use.
4. Power dissipation and forward current are the value when the module temperature is set lower than the rating by using an adequate heat sink.

PN of the GXUAN1313 Series : White LEDs



Order Code of GXUAN1313	Minimum Luminous Flux (lm) @Tb=85°C	Typical Luminous Flux (lm) @Tb=85°C	Typical Luminous Flux (lm) @Tb=25°C	CCT (K)	Forward Voltage (V)	Forward Current (mA)	CRI (min.)
XUAN1313-LM27327-36206-492T	750	833	926	27M3	31.0~37.0	180	70
XUAN1313-LM30330-36206-492T	795	883	981	30M3	31.0~37.0	180	70
XUAN1313-LM35335-36206-492T	819	910	1012	35M3	31.0~37.0	180	70
XUAN1313-LM40340-36206-492T	832	925	1027	40M3	31.0~37.0	180	70
XUAN1313-GT50550-36206-492T	860	956	1062	50M5	31.0~37.0	180	70
XUAN1313-GT57557-36206-492T	870	966	1074	57M5	31.0~37.0	180	70
XUAN1313-GT65565-36206-492T	870	966	1074	65M5	31.0~37.0	180	70
GXUAN1313-KM27327-36206-492T	707	786	873	27M3	31.0~37.0	180	80
GXUAN1313-KM30330-36206-492T	750	833	926	30M3	31.0~37.0	180	80
GXUAN1313-KM35335-36206-492T	773	859	954	35M3	31.0~37.0	180	80
GXUAN1313-KM40340-36206-492T	785	872	969	40M3	31.0~37.0	180	80
GXUAN1313-KT50550-36206-492T	811	902	1002	50M5	31.0~37.0	180	80
GXUAN1313-KT57557-36206-492T	820	912	1013	57M5	31.0~37.0	180	80
GXUAN1313-KT65565-36206-492T	820	912	1013	65M5	31.0~37.0	180	80
GXUAN1313-PM27327-36206-492T	618	687	763	27M3	31.0~37.0	180	90
GXUAN1313-PM30330-36206-492T	662	735	817	30M3	31.0~37.0	180	90
GXUAN1313-PM35335-36206-492T	670	745	828	35M3	31.0~37.0	180	90
GXUAN1313-PM40340-36206-492T	688	764	849	40M3	31.0~37.0	180	90

Notes:

1. CRI measurement tolerance: ± 2 .
2. Luminous flux measurement tolerance: $\pm 10\%$.
3. The data of luminous flux measured at thermal pad=25°C
4. Typical luminous flux or light output performance is operated within the condition guided by this datasheet.

Product Binning

Warm-White Bin Structure

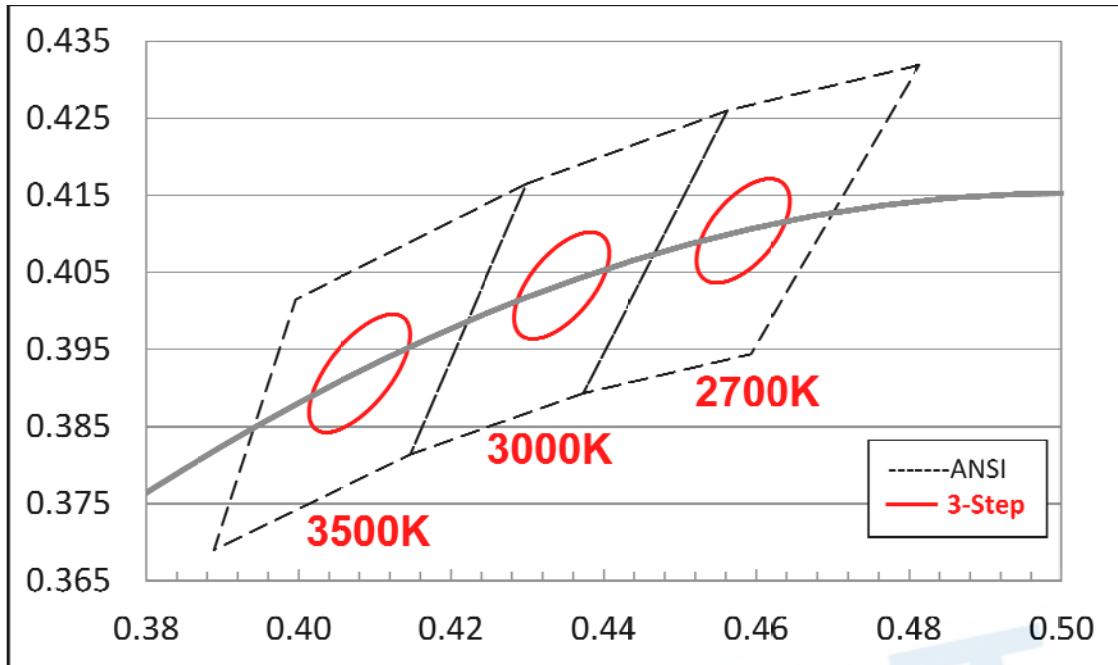

Warm-White Bin Coordinates

2700K

Bin	Center-CIE X	Center-CIE Y
27M3	0.4583	0.4101
	Oval parameter	
	a	0.0081
	b	0.0042
	theta	49.7

Bin	CIE X	CIE Y
ANSI	0.4813	0.4319
	0.4562	0.4260
	0.4373	0.3893
	0.4593	0.3944
Reference Range: 2580~2869K		

3000K

Bin	Center-CIE X	Center-CIE Y
30M3	0.4345	0.4033
	Oval parameter	
	a	0.00834
	b	0.00408
	theta	50.22

Bin	CIE X	CIE Y
ANSI	0.4562	0.4260
	0.4299	0.4165
	0.4147	0.3814
	0.4373	0.3893
Reference Range: 2858~3209K		

3500K

Bin	Center-CIE X	Center-CIE Y
35M3	0.4080	0.3919
	Oval parameter	
	a	0.00927
	b	0.00414
	theta	51.00

Bin	CIE X	CIE Y
ANSI	0.4299	0.4165
	0.3996	0.4015
	0.3889	0.3690
	0.4147	0.3814
Reference Range: 3209~3710K		

Neutral-White Bin Structure

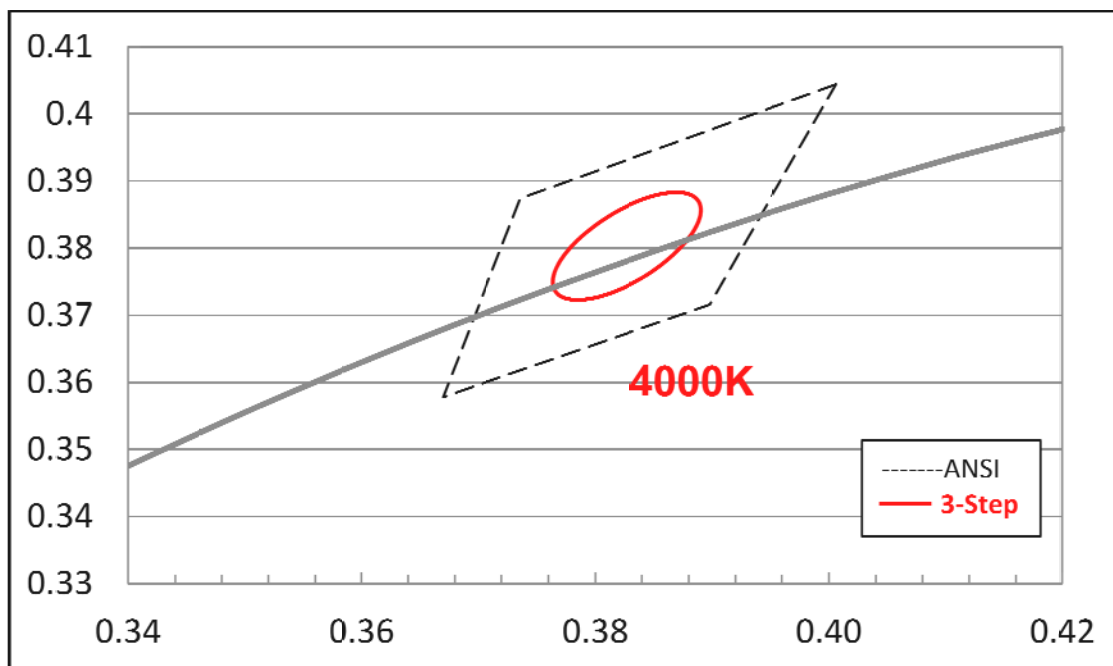

Neutral-White Bin Coordinates

4000K

Bin	Center-CIE X	Center-CIE Y
40M3	0.3827	0.3803
	Oval parameter	
	a	0.00939
	b	0.00402
	theta	54.80

Bin	CIE X	CIE Y
ANSI	0.4006	0.4044
	0.3736	0.3874
	0.3670	0.3578
	0.3898	0.3716
Reference Range: 3709~4260K		

Cool-White Bin Structure

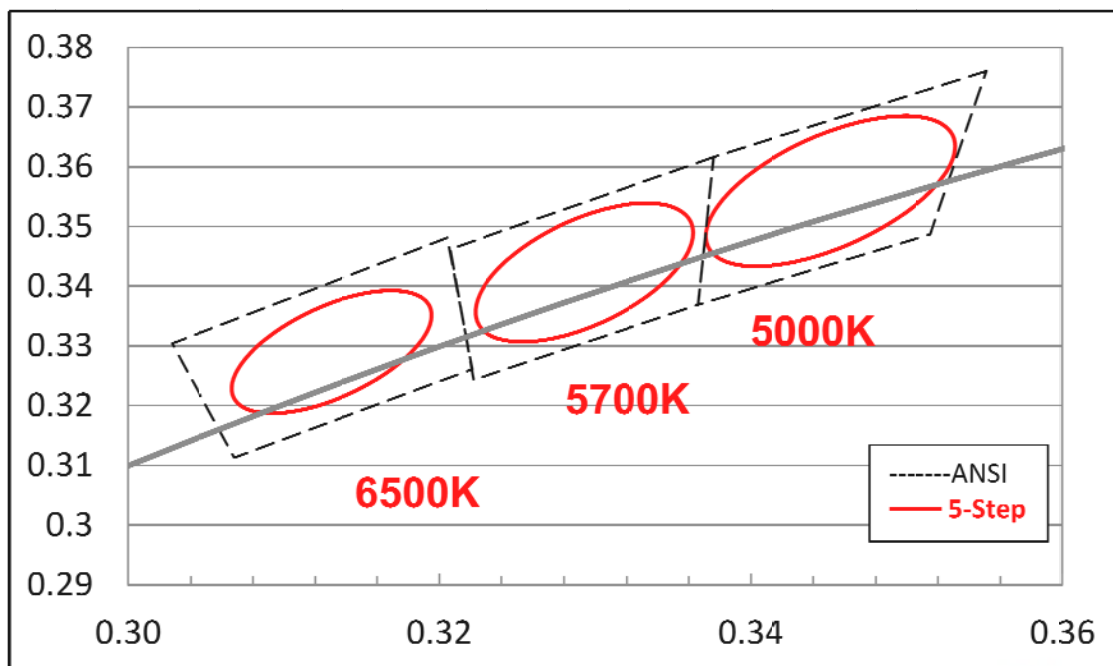

Cool-White Bin Coordinates

5000K

Bin	Center-CIE X	Center-CIE Y
50M5	0.3451	0.3559
	Oval parameter	
	a	0.01370
	b	0.00590
	theta	64.12

Bin	CIE X	CIE Y
ANSI	0.3551	0.3760
	0.3376	0.3616
	0.3366	0.3369
	0.3515	0.3487
Reference Range: 4744~5310K		

5700K

Bin	Center-CIE X	Center-CIE Y
57M5	0.3293	0.3423
	Oval parameter	
	a	0.01245
	b	0.00535
	theta	66.51

Bin	CIE X	CIE Y
ANSI	0.3376	0.3616
	0.3207	0.3462
	0.3222	0.3243
	0.3366	0.3369
Reference Range: 5308~6020K		

6500K

Bin	Center-CIE X	Center-CIE Y
65M5	0.3131	0.3290
	Oval parameter	
	a	0.01115
	b	0.00475
	theta	64.57

Bin	CIE X	CIE Y
ANSI	0.3205	0.3481
	0.3028	0.3304
	0.3068	0.3113
	0.3221	0.3261
Reference Range: 6020~7043K		

Notes:

1. Color coordinates measurement allowance : ± 0.01 .

Forward Voltage Bins

Bin	Minimum Forward Voltage (V)	Maximum Forward Voltage (V)
W4	31.0	37.0

Notes:

1. Forward voltage measurement tolerance: $\pm 2\%$.
2. Forward voltage bins are defined at $I_f=180\text{mA}$ operation.
3. Other Forward Voltage bins for White LEDs available upon request. Please contact your local Everlight sales office.

EVERLIGHT

Mechanical Dimension

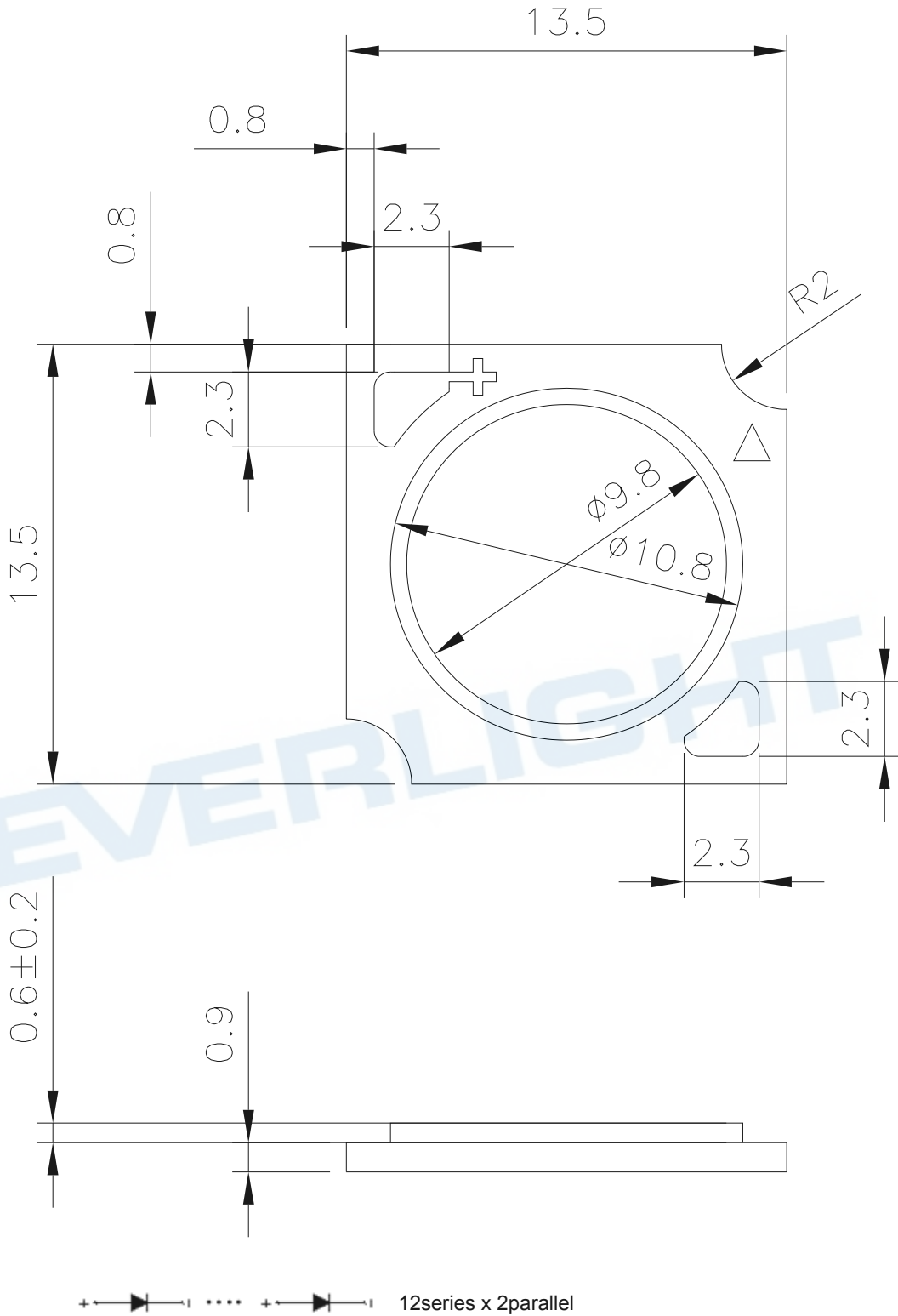

Note:

1. Dimensions are in millimeters.
2. Tolerances unless mentioned are ± 0.1 mm.

Pad Configuration

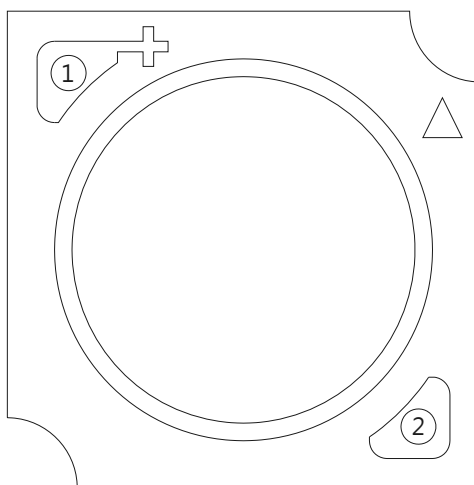

PAD	FUNCTION
1	ANODE
2	CATHODE

Typical Electro-Optical Characteristic Curve

Relative Spectral Distribution
@ Substrate Temperature = 25°C

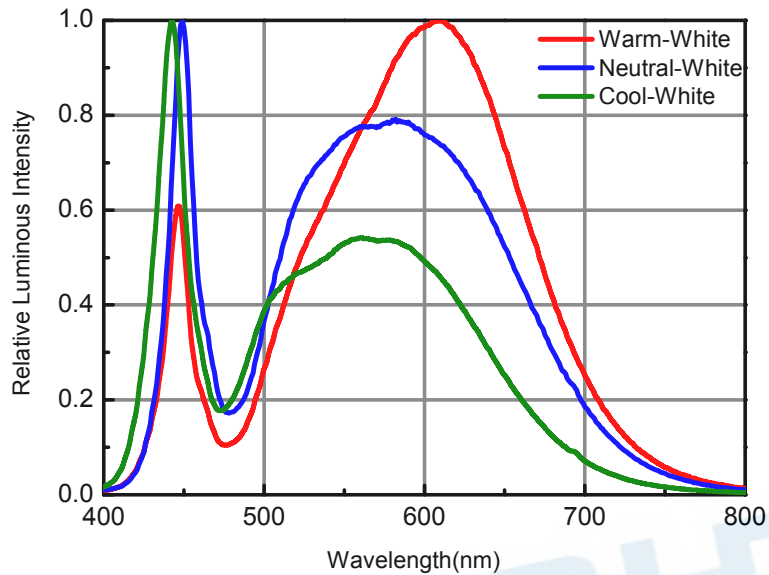

Relative Luminous Flux vs. Substrate Temperature
@Forward Current = 180mA

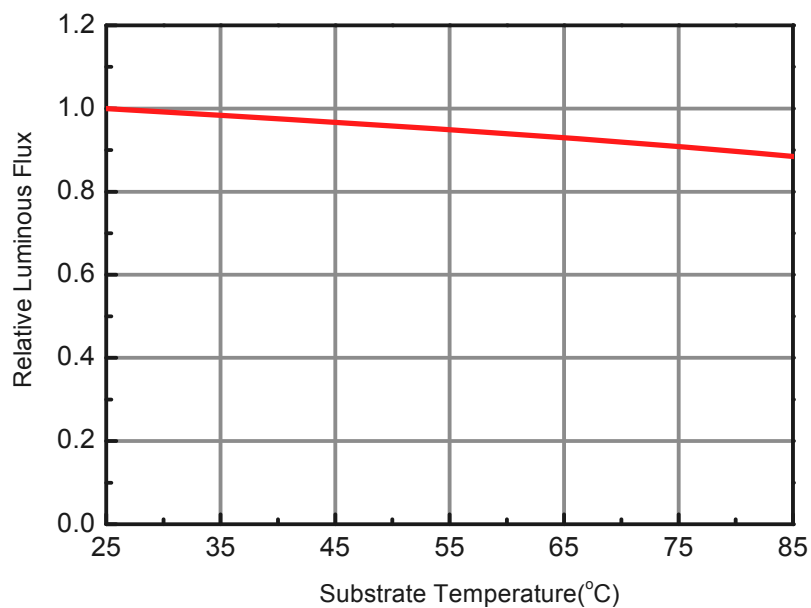

Forward Voltage vs. Forward Current
@ Substrate Temperature = 25°C

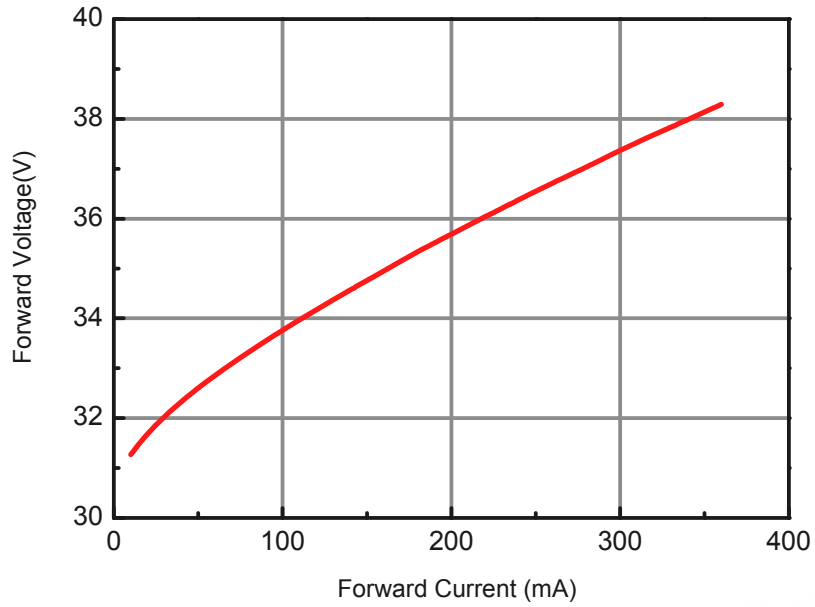

Luminous Flux vs. Forward Current
@ Substrate Temperature = 25°C

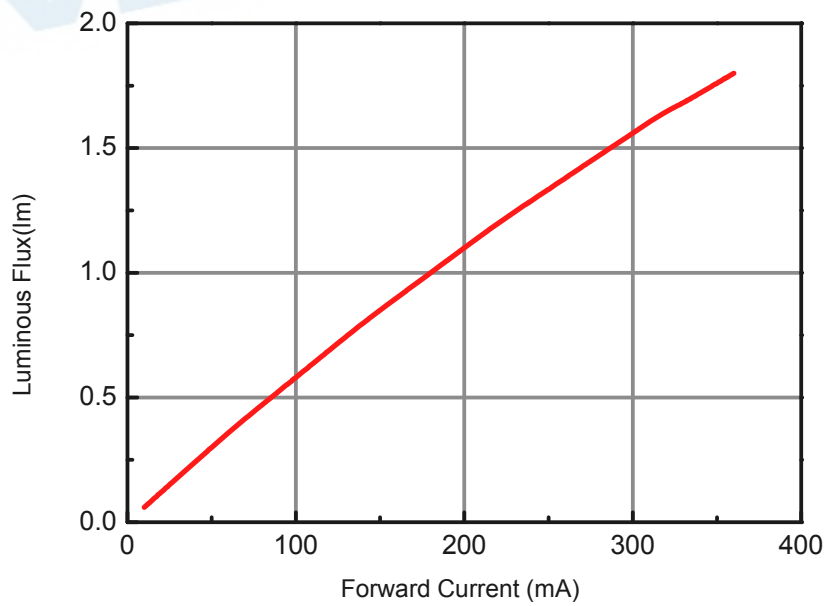

Correlated Color Temperature vs. Forward Current
@ Substrate Temperature = 25°C

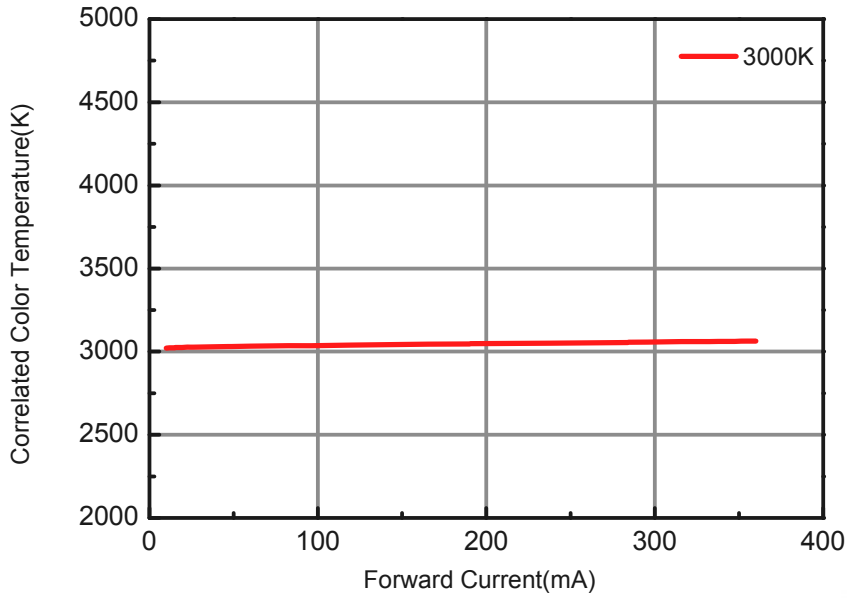

Correlated Color Temperature vs. Substrate Temperature
@ Forward Current = 180mA

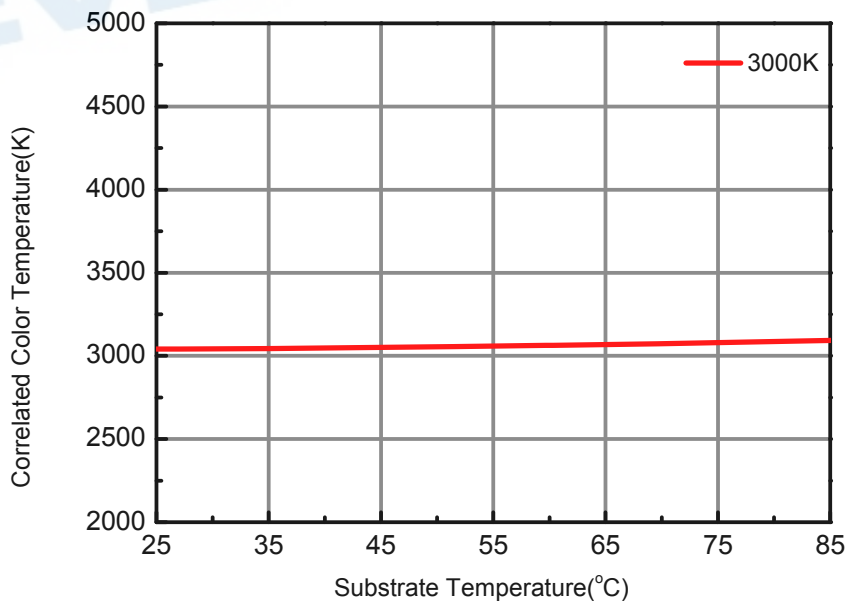

Forward Voltage vs. Substrate Temperature
@ Forward Current = 180mA

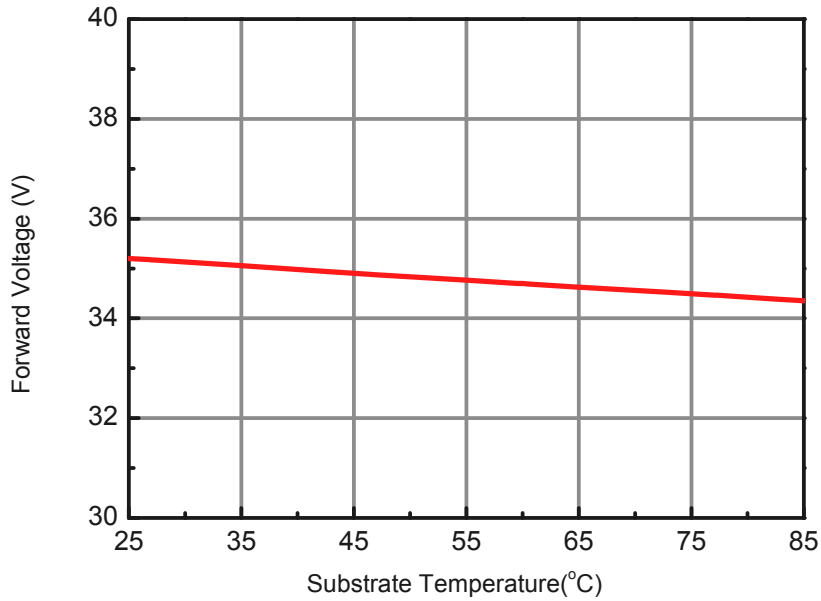

Forward Current Derating Curve
@ Junction Temperature <120°C

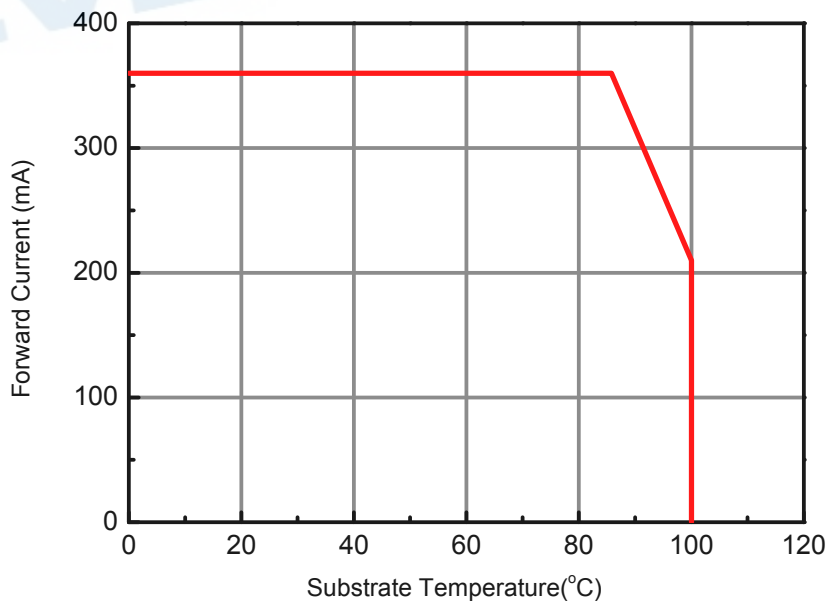

Typical Diagram Characteristics of Radiation Patterns

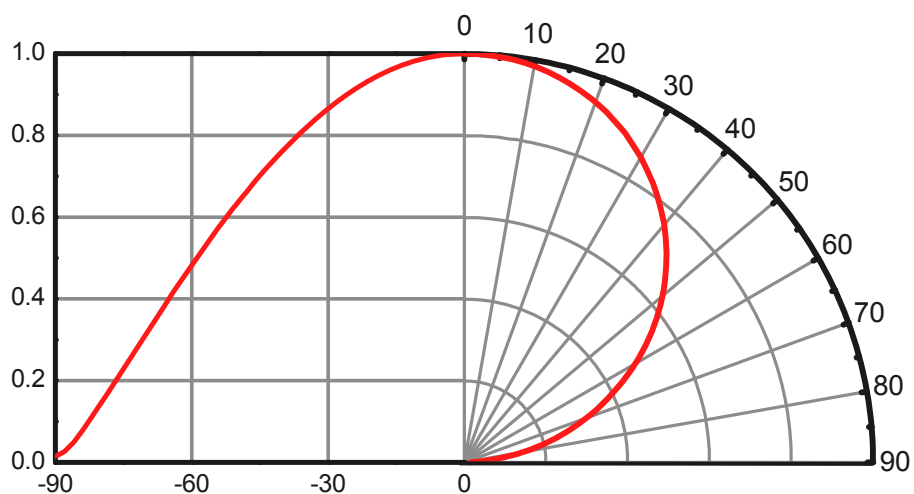

Notes:

1. $2\theta_{1/2}$ is the off axis angle from lamp centerline where the luminous intensity is 1/2 of the peak value.
2. Viewing angle tolerance is $\pm 5^\circ$

EVERLIGHT

Product Labeling

Label Explanation

CPN: Customer Specification (when required)

P/N : Everlight Production Number

QTY: Packing Quantity

CAT: Luminous Flux (Brightness) Bin

HUE: Color Bin

REF: Forward Voltage Bin

LOT No: Lot Number

MADE IN TAIWAN: Production Place



Carrier Tray Specification

Loaded Quantity: 63 PCS Per Tray

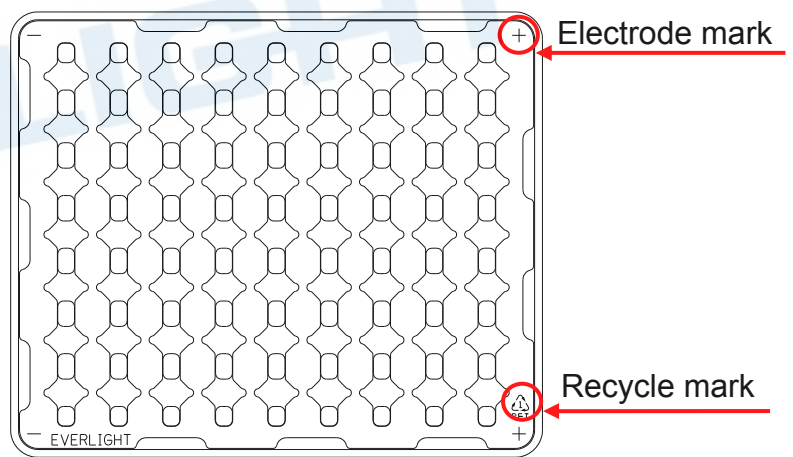
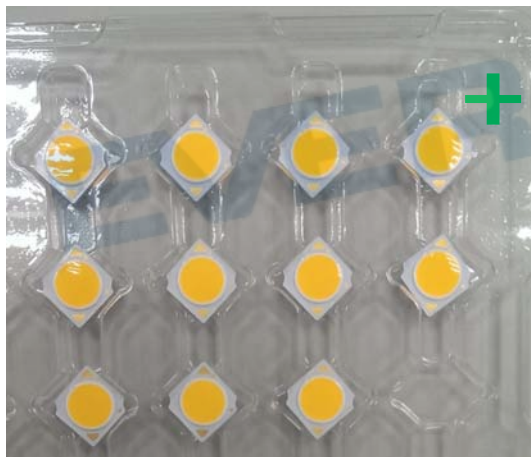

Notes:

1. Dimensions are in millimeters
2. Tolerances unless mentioned are $\pm 0.1\text{mm}$

LED Direction

- The **Recycle mark** on the LEDs will be toward the **Anode mark** on the carrier tray.

Moisture Resistant Packaging



Outside Carton

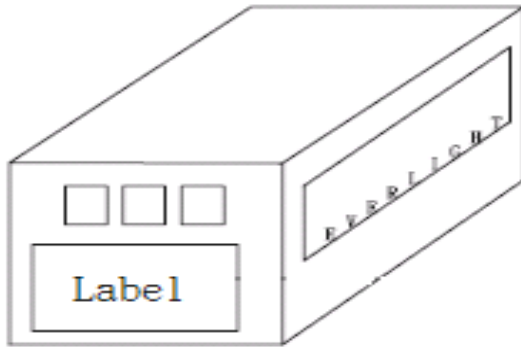

RoHS **Pb** **EVERLIGHT** 5

CPN: XXXXXXXXXXXXXXXXXXXX 測試區
XXXXXXXXXX-XXXXXXXXXX-XXXXXXXXXX-XXXXXXXXXX-XXXXXX
P/N: XXXXXXXXXXXX
XXXXXXXXXX-XXXXXXXXXX-XXXXXXXXXX-XXXXXXXXXX-XXXXXX
LOT NO: Y150716XXX-XXXXXXXXXX-XXXXXXXXXX
QTY: 0123456789 HUE: XXXXXXXXXXXX
CAT: XXXXXXXXXXXX REF: XXXXXXXXXXXX
REFERENCE: BTPYYMDDXXXXX
MSL-2a MADE IN TAIWAN



Packaging Quantity

- 63 PCS Per Tray
- 20 Trays Per Outside Carton



Precautions of Use

Over-Current-Proof

- Though the GXUAN1313 has a conducted ESD protection mechanism, customers must not use the device in reverse and should apply resistors for extra protection. Otherwise slight voltage shift may cause significant current changes and burn out failure may happen.

Storage Conditions

- Before the package is opened: The LEDs should be stored at 30°C or less and 50%RH or less after being shipped from Everlight and the storage life limit is 6 months. If the LEDs are stored for 6 months or more, they should be stored in a sealed container with a nitrogen atmosphere and moisture absorbent material.
- After opening the package: The LED should be stored under 30°C or less and 30%RH or less. The LED should be used within 168hrs (7days) after opening the package. If unused LEDs remain, it should be stored in moisture proof packages.
- Do not stack assemblies.



Handling

- Do not put mechanical stress on the LED.
- Never touch the optical surface with finger or sharp object. The LED surface could be soiled or damaged, which could affect the optical performance of the LED.
- In low-humidity work environment, please keep handling the LEDs with appropriate ESD grounding.
- It is recommended to handle the LED with powder-less latex gloves.

Manual Handling

- When handling the product, do not apply direct pressure on the optical surface.
- Do not touch the resin with tweezers to avoid scratching or other damage.

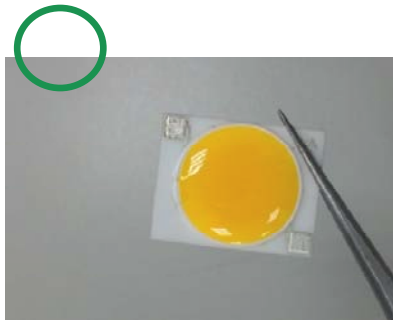

Thermal Management

- Sufficient thermal management must be implemented. Substrate of the positive in temperature must be kept under 85°C at the driving current of 180mA. Otherwise, the junction temperature of die may exceed the limit at high current driving conditions and the LEDs' lifetime may be decrease dramatically.

DISCLAIMER

1. EVERLIGHT reserves the right(s) on the adjustment of product material mix for the specification.
2. The product meets EVERLIGHT published specification for a period of twelve (12) months from date of shipment.
3. The graphs shown in this datasheet are representing typical data only and do not show guaranteed values.
4. When using this product, please observe the absolute maximum ratings and the instructions for using outlined in these specification sheets. EVERLIGHT assumes no responsibility for any damage resulting from the use of the product which does not comply with the absolute maximum ratings and the instructions included in these specification sheets.
5. These specification sheets include materials protected under copyright of EVERLIGHT. Reproduction in any form is prohibited without obtaining EVERLIGHT's prior consent.
6. This product is not intended to be used for military, aircraft, automotive, medical, life sustaining or life saving applications or any other application which can result in human injury or death. Please contact authorized Everlight sales agent for special application request.

Revision History

Current version: **2016/06/04**

Previous version: **N/A**

Device No. DHE-0003080

Rev. Ver. 2

Page	Subjects (major change in previous version)	Date of change
20	Add a DISCLAIMER	2017/03/09

EVERLIGHT