

4 PIN DIP HIGH VOLTAGE PHOTOTRANSISTOR PHOTOCOUPLER EL851 Series

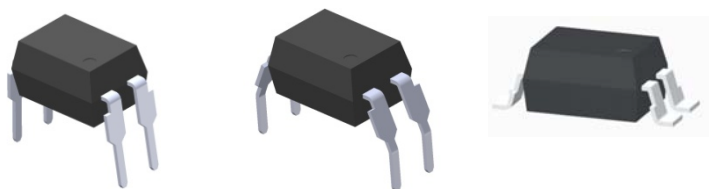

Schematic

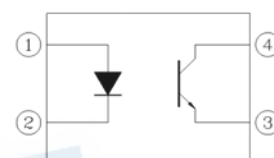

Pin Configuration

1. Anode
2. Cathode
3. Emitter
4. Collector

Features:

- Compliance Halogens Free (Only copper leadframe)
(Br < 900 ppm, Cl < 900 ppm, Br+Cl < 1500 ppm)
- High collector- emitter voltage ($V_{CEO} = 350V$)
- Current transfer ratio
(CTR: 50~600% at $I_F = 5mA$, $V_{CE} = 5V$)
- High isolation voltage between input and output ($V_{iso} = 5000 V_{rms}$)
- Compact dual-in-line package
- The product itself will remain within RoHS compliant version
- Compliance with EU REACH
- Pb free
- UL and cUL approved (No. E214129)
- VDE approved (No. 132249)
- SEMKO approved
- NEMKO approved
- DEMKO approved
- FIMKO approved
- CQC approved

Description

The EL851 series devices consist an infrared emitting diodes, optically coupled to a phototransistor detector.

The devices are in a 4-pin DIP package and available in wide-lead spacing and SMD option.

Applications

- Telephone line interface
- Interface to power supply circuit
- Controller for SSRs. DC motor
- Programmable Controllers

Absolute Maximum Ratings (Ta=25°C)

	Parameter	Symbol	Rating	Unit
Input	Forward current	I _F	60	mA
	Peak forward current (1μs pulse)	I _{FM}	1	A
	Reverse voltage	V _R	6	V
	Power dissipation	P _D	100	mW
Output	Collector power dissipation	P _C	150	mW
	Collector-Emitter voltage	V _{CEO}	350	V
	Collector Current	I _C	50	mA
	Emitter-Collector voltage	V _{ECO}	7	V
	Total Power Dissipation	P _{TOT}	200	mW
	Isolation Voltage*1	V _{ISO}	5000	V rms
	Operating Temperature	T _{OPR}	-55 to 100	°C
	Storage Temperature	T _{STG}	-55 to 125	°C
	Soldering Temperature*2	T _{SOL}	260	°C

Notes:

*1 AC for 1 minute, R.H.= 40 ~ 60% R.H. In this test, pins 1, 2 are shorted together, and pins 3, 4 are shorted together.

*2 For 10 seconds

Electro-Optical Characteristics (Ta=25°C unless specified otherwise)

Input

Parameter	Symbol	Min.	Typ.	Max.	Unit	Condition
Forward Voltage	V _F	-	1.2	1.4	V	I _F = 10mA
Reverse Current	I _R	-	-	10	μA	V _R = 5V
Input capacitance	C _{in}	-	30	250	pF	V = 0, f = 1kHz

Note: Reverse Voltage(V_R) Condition is applied to I_R test only The device is not designed for reverse operation

Output

Parameter	Symbol	Min	Typ.	Max.	Unit	Condition
Collector-Emitter dark current	I _{CEO}	-	-	100	nA	V _{CE} = 200V
Collector-Emitter breakdown voltage	BV _{CEO}	350	-	-	V	I _C = 0.1mA
Emitter-Collector breakdown voltage	BV _{ECO}	7	-	-	V	I _E = 0.1mA
Collector-Emitter capacitance	C _{CE}	-	10	-	pF	V _{CE} = 0V, f = 1MHz

Transfer Characteristics

Parameter	Symbol	Min	Typ.	Max.	Unit	Condition
Current Transfer Ratio	CTR	50	-	600	%	I _F = 5mA, V _{CE} = 5V
Collector-emitter saturation voltage	V _{CE(sat)}	-	-	0.4	V	I _F = 20mA, I _C = 1mA
Isolation resistance	R _{IO}	10 ¹¹	-	-	Ω	V _{IO} = 500Vdc
Input-output capacitance	C _{IO}	-	0.6	-	pF	V _{IO} = 0, f = 1MHz
Rise time	t _r	-	4	18	μs	V _{CE} = 2V, I _C = 2mA,
Fall time	t _f	-	5	18	μs	R _L = 100Ω

* Typical values at T_a = 25°C

Typical Electro-Optical Characteristics Curves

Figure 1. Forward Current vs Forward Voltage

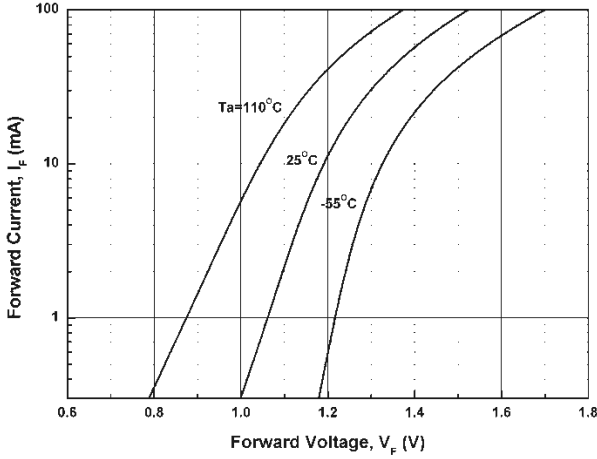

Figure 2. Current Transfer Ratio vs Forward Current

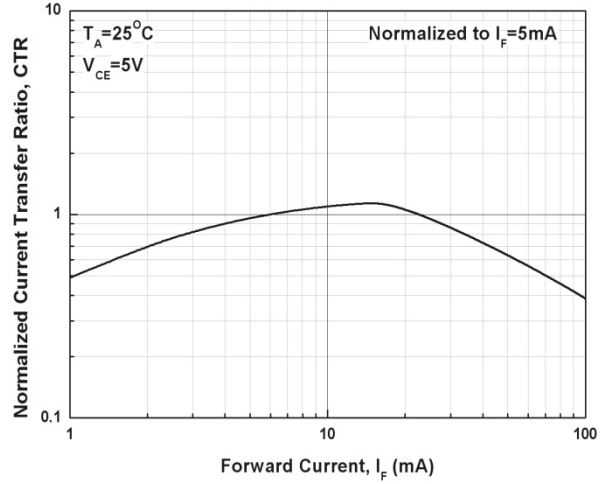

Figure 3. Collector Current vs Collector-emitter Voltage

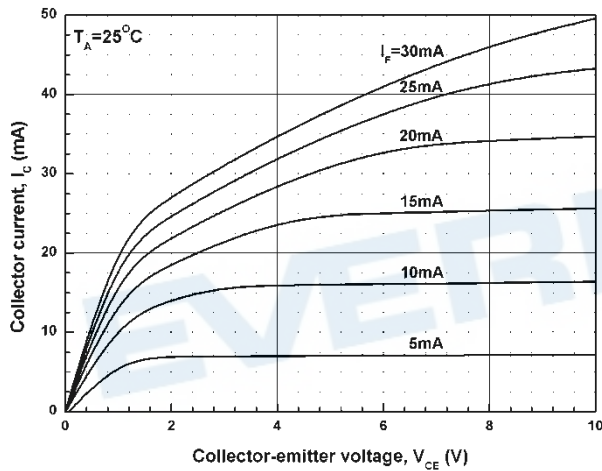

Figure 4. Relative Current Transfer Ratio vs Ambient Temperature

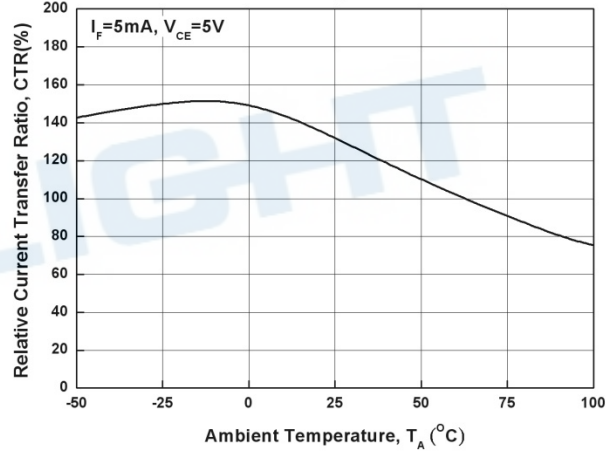

Figure 5. Collector-emitter Saturation Voltage vs Ambient Temperature

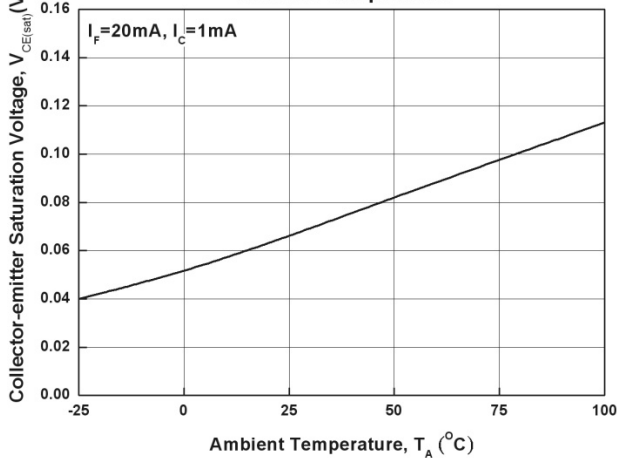

Figure 6. Dark Current vs Ambient Temperature

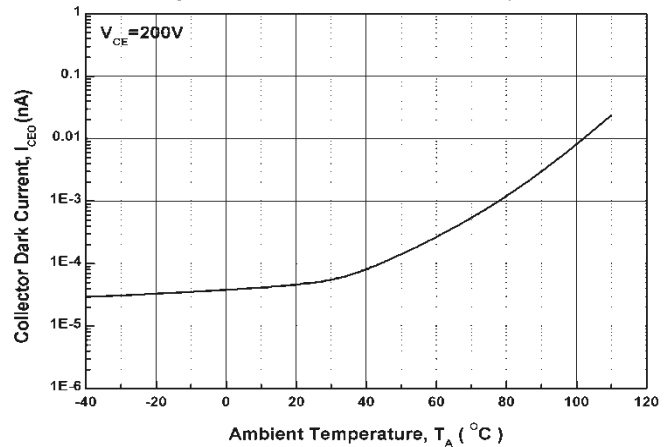

Figure 7. Switching Time vs. Load Resistance

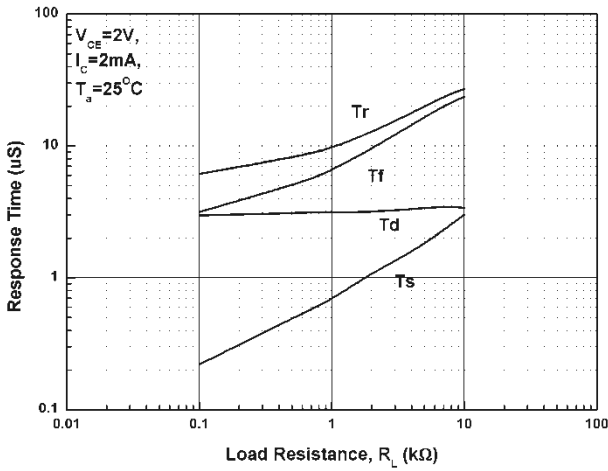

Figure 8. Collector-emitter Saturation Voltage vs Forward Current

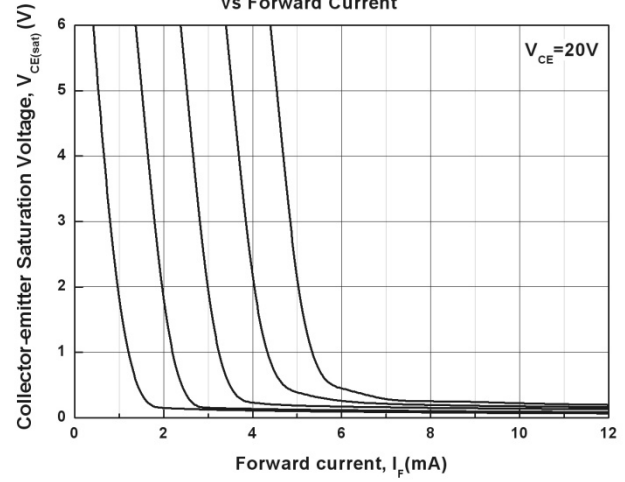
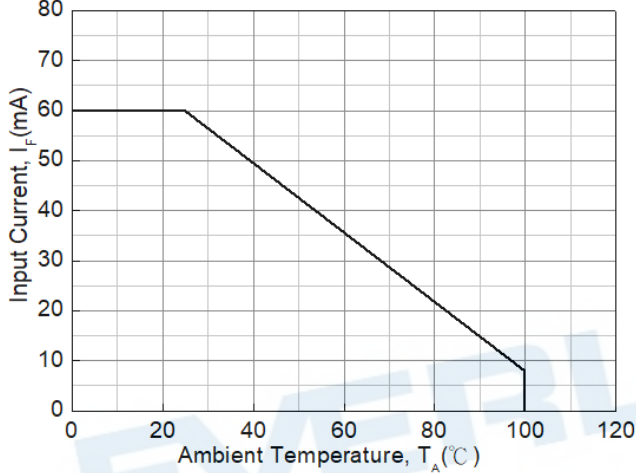

Figure 9. Input Current vs Ambient Temperature



Note: The graphs shown in this datasheet are representing typical data only and do not show guaranteed values

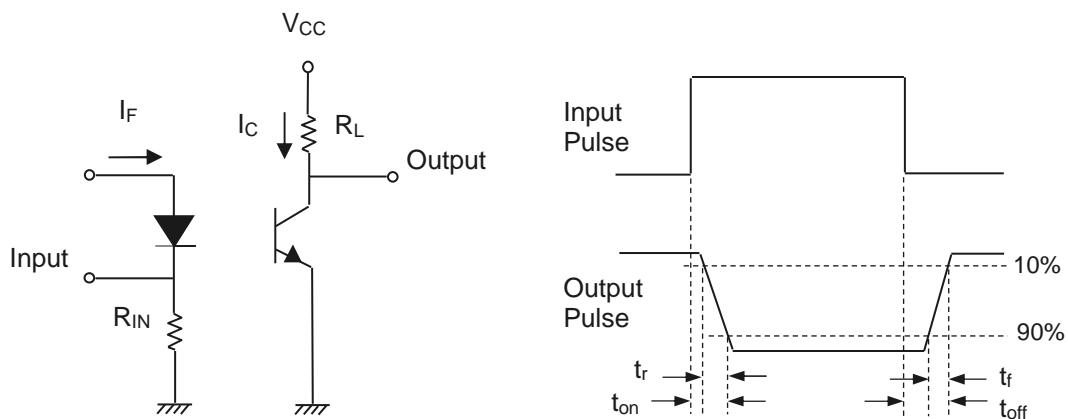

Figure 10. Switching Time Test Circuit & Waveforms

Order Information

Part Number

EL851X(Z)-V

Note

- X = Lead form option (S1, M or none)
- Z = Tape and reel option (TA, TB, TU, TD or none)
- V = VDE safety (optional)

Option	Description	Packing quantity
None	Standard DIP-4	100 units per tube
M	Wide lead bend (0.4 inch spacing)	100 units per tube
S1 (TA)	Surface mount lead form (low profile) + TA tape & reel option	1000 units per reel
S1 (TB)	Surface mount lead form (low profile) + TB tape & reel option	1000 units per reel
S1 (TU)	Surface mount lead form (low profile) + TU tape & reel option	2000 units per reel
S1 (TD)	Surface mount lead form (low profile) + TD tape & reel option	2000 units per reel

Package Dimension (Dimensions in mm)

Standard DIP Type

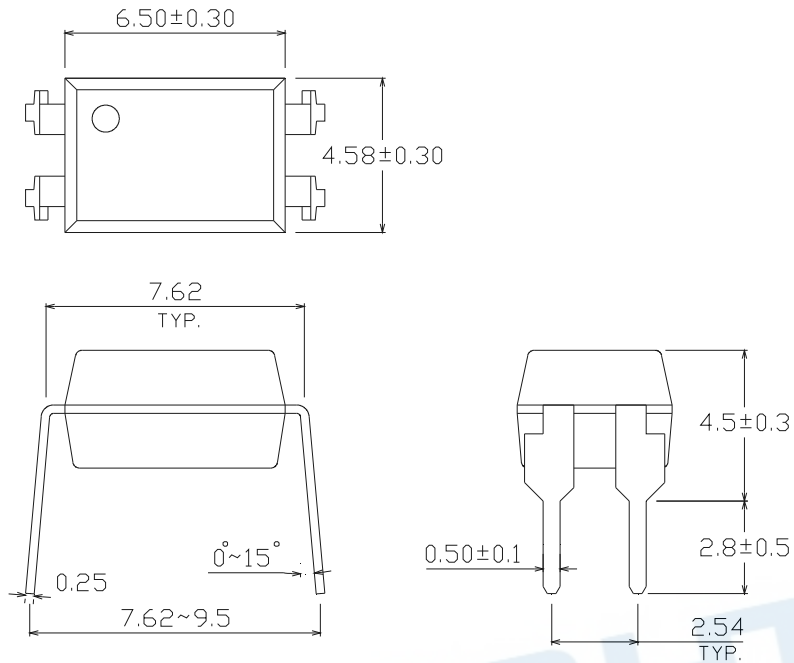

Option M Type

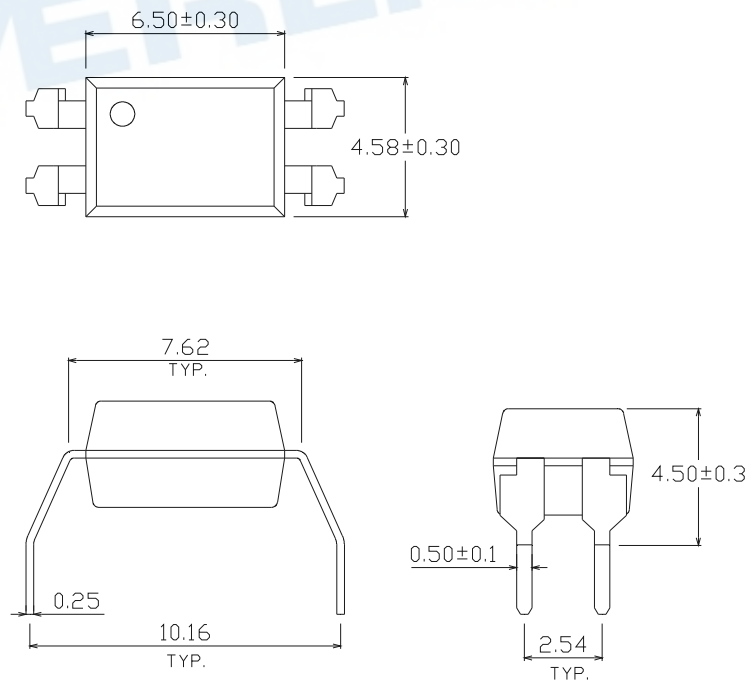

Option S1 Type

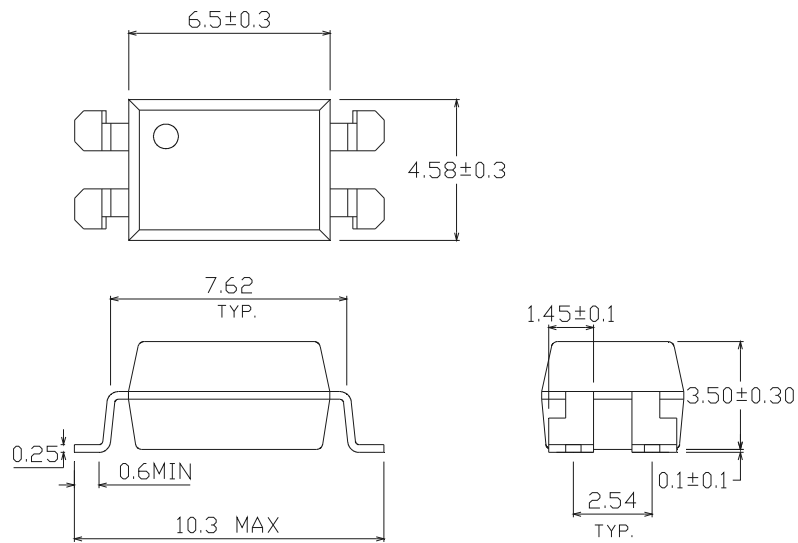

Recommended pad layout for surface mount leadform

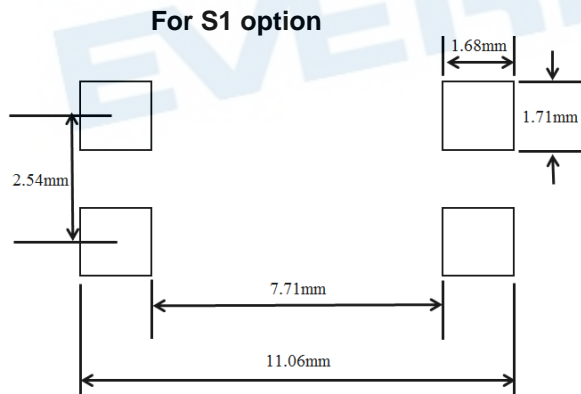

Notes

Suggested pad dimension is just for reference only.
Please modify the pad dimension based on individual need.

Device Marking





Notes

EL	denotes EVERLIGHT
851	denotes Device Number
Y	denotes 1 digit Year code
WW	denotes 2 digit Week code
V	denotes VDE (optional)

EVERLIGHT

Label form

EVERLIGHT
11 → 月份



客戶料號 ← CPN: XXXXXXXXXXXX 測試區
  → RoHS標示

億光料號 ← P/N: XXXXXXXXXXXX
  → 安規標示

億光品名 ← EL817M(C)-VG



生產周別 ← D/C: YWWX CAT: X QTY: 000000

 REF: XXXX  → 包裝數量

生產序號 ← LOT NO: Y151130XXXXXXXXXX



標籤識別碼 ← REFERENCE: BTPyyMMddXXXXX

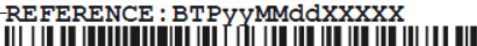

 → QR Code

產地 ← MADE IN XXXXXX

or

RoHS 標示

EVERLIGHT
5 → 月份

客戶料號 ← CPN: XXXXXXXXXXXX 測試區
  → 安規標示

客戶品名 ← XXXXXXXXXXX-XXXXXXXX-XXXXXXXX-XXXXXXXX-XXXXXX

億光料號 ← P/N: XXXXXXXXXXXX

億光品名 ← XXXXXXXXXXX-XXXXXXXX-XXXXXXXX-XXXXXX

生產序號 ← LOT NO: Y150516XXX-XXXXXXXXXX-XXXXXXXXXX





包裝數量 ← QTY: 0123456789 HUE: XXXXXXXXXXXX



CTR等級 ← CAT: XXXXXXXXXXXX REF: XXXXXXXXXXXX



標籤識別碼 ← REFERENCE: BTPYMMDDXXXXX



 → QR Code

MSL等級 ← MSL-XX MADE IN XXXXXX

↓

 產地

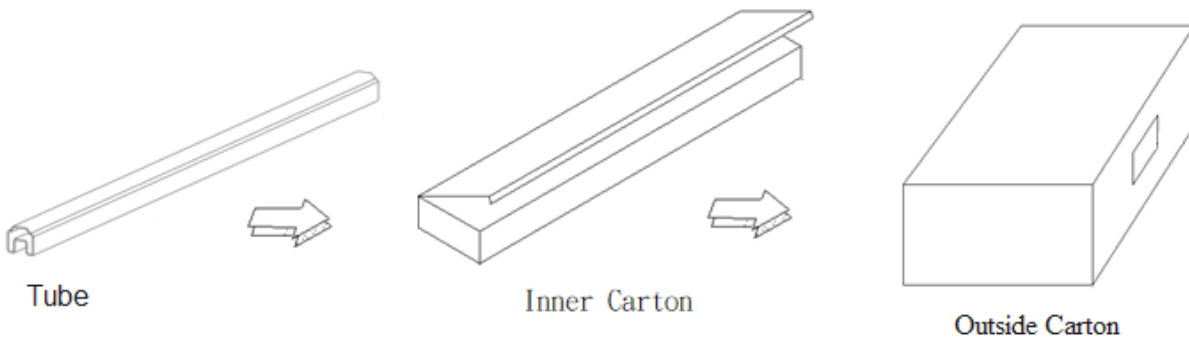
TUBE Dimension



Reel Dimension

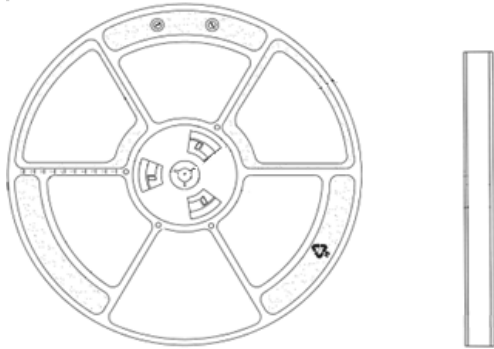

Moisture Resistant Packaging

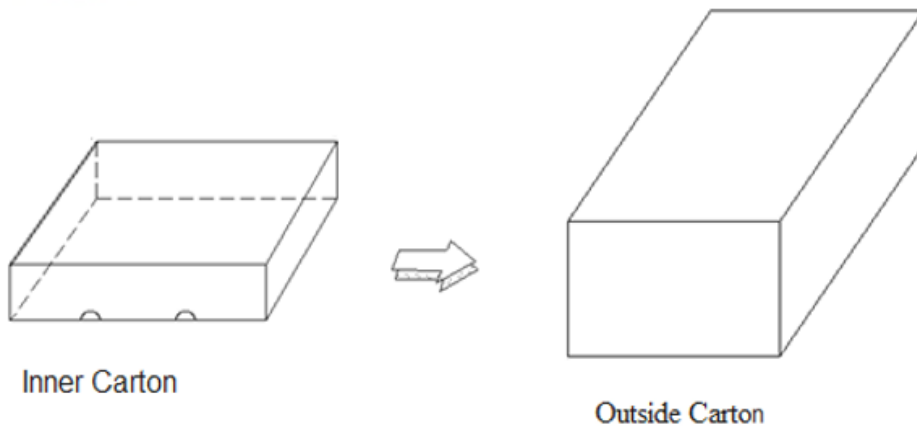
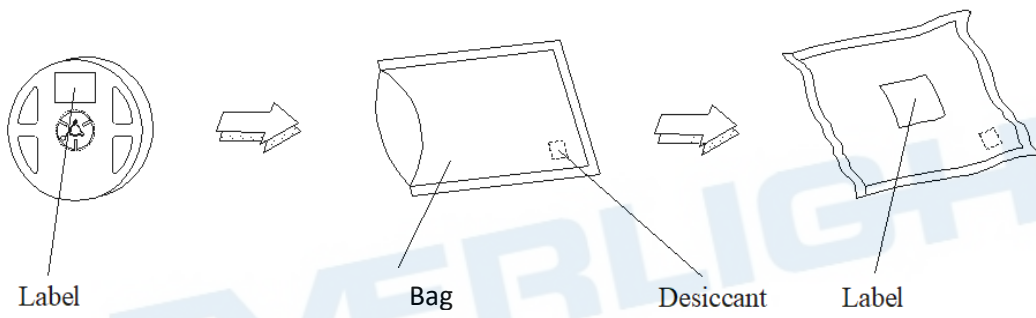

Tape & Reel Packing Specifications

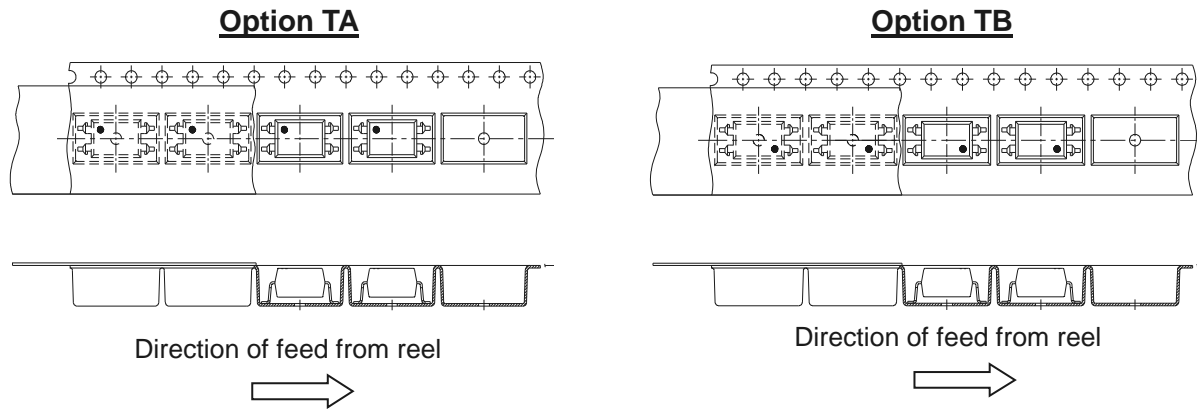

Tape dimensions

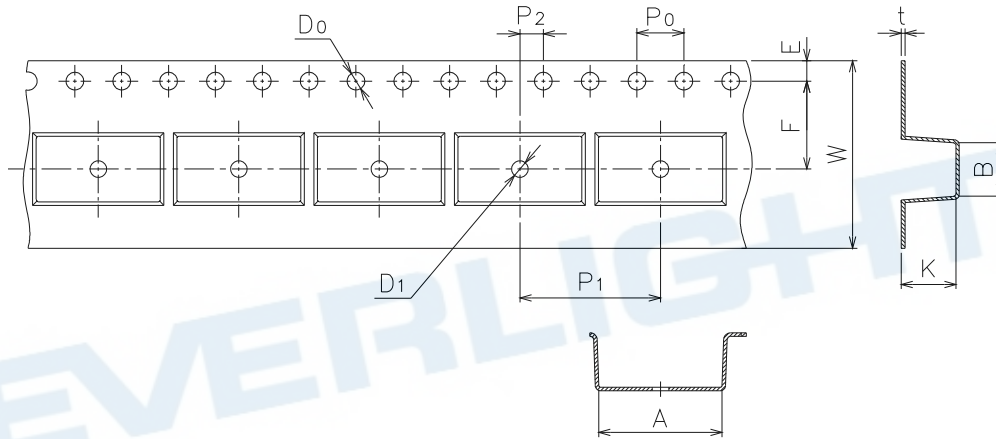

Dimension No.	A	B	Do	D1	E	F
Dimension (mm) S1	10.7±0.1	4.65±0.1	1.5±0.1	1.50±0.1	1.75±0.1	7.5±0.1
Dimension No.	Po	P1	P2	t	W	K
Dimension (mm) S1	4.0±0.1	12.0±0.1	2.0±0.1	0.4±0.1	16.0±0.3	3.90±0.1

Tape & Reel Packing Specifications

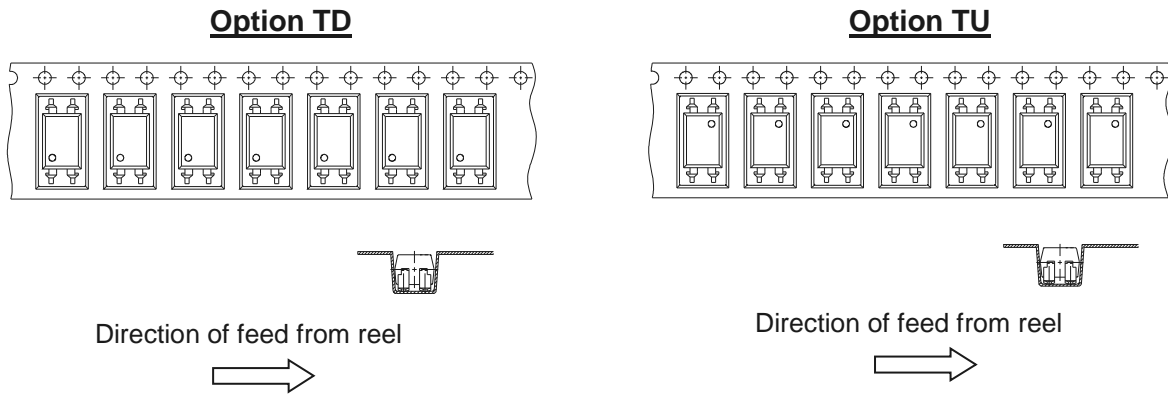

Tape dimensions

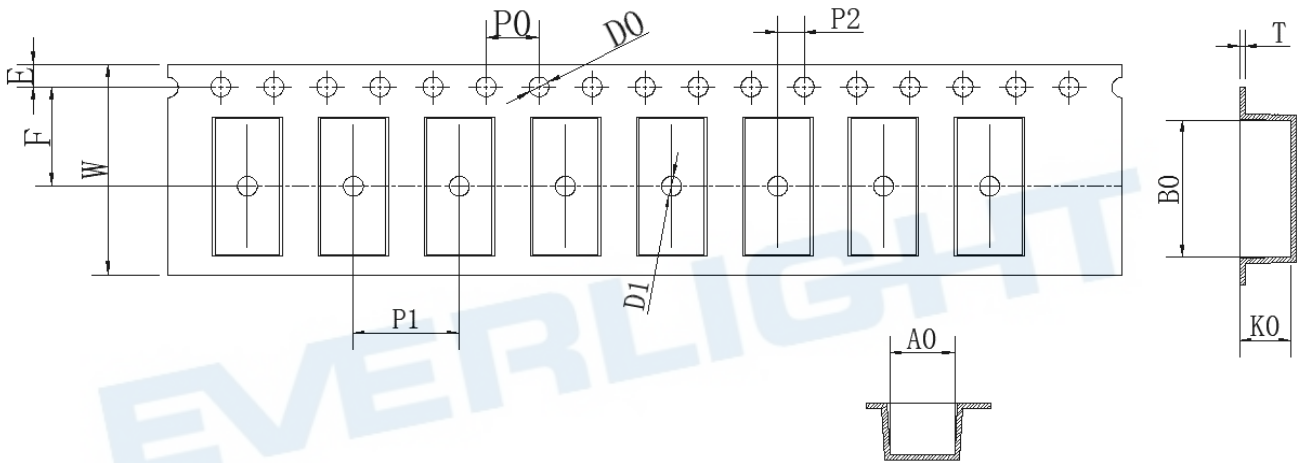

Dimension No.	Ao	Bo	Do	D1	E	F
Dimension (mm)	4.90±0.1	10.40±0.1	1.5±0.1	1.50±0.1	1.75±0.1	7.50±0.1
Dimension No.	Po	P1	P2	t	W	Ko
Dimension(mm)	4.00±0.1	8.00±0.1	2.00±0.1	0.40±0.1	16.00±0.3	4.00±0.1

Precautions for Use

1. Soldering Condition

1.1 (A) Maximum Body Case Temperature Profile for evaluation of Reflow Profile

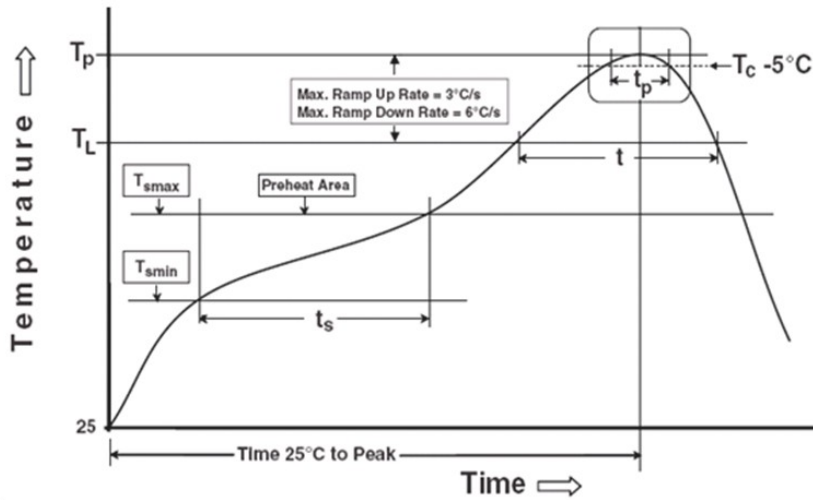

Note:

Reference: IPC/JEDEC J-STD-020D

Preheat

Temperature min (T_{smin})	150 °C
Temperature max (T_{smax})	200°C
Time (T_{smin} to T_{smax}) (t_s)	60-120 seconds
Average ramp-up rate (T_{smax} to T_p)	3 °C/second max

Other

Liquidus Temperature (T_L)	217 °C
Time above Liquidus Temperature (t_L)	60-100 sec
Peak Temperature (T_P)	260°C
Time within 5 °C of Actual Peak Temperature: $T_P - 5^\circ\text{C}$	30 s
Ramp- Down Rate from Peak Temperature	6°C /second max.
Time 25°C to peak temperature	8 minutes max.
Reflow times	3 times

Precautions for General Storage

- Avoid storage locations where devices may be exposed to moisture or direct sunlight.
- Follow the precautions printed on the packing label of the device for transportation and storage.
- Keep the storage location temperature and humidity within a range of 5°C to 35°C and 20 % to 60 %, respectively.
- Do not store the products in locations with poisonous gases (especially corrosive gases) or in dusty conditions.
- Store the products in locations with minimal temperature fluctuations. Rapid temperature changes during storage can cause condensation, resulting in lead oxidation or corrosion, which will deteriorate the solderability of the leads.
- When restoring devices after removal from their packing, use anti-static containers.
- Do not allow loads to be applied directly to devices while they are in storage.
- If devices have been stored for more than two years under normal storage conditions, it is recommended that you check the leads for ease of soldering prior to use.

EVERLIGHT

DISCLAIMER

1. Above specification may be changed without notice. EVERLIGHT will reserve authority on material change for above specification.
2. The graphs shown in this datasheet are representing typical data only and do not show guaranteed values.
3. When using this product, please observe the absolute maximum ratings and the instructions for use outlined in these specification sheets. EVERLIGHT assumes no responsibility for any damage resulting from use of the product which does not comply with the absolute maximum ratings and the instructions included in these specification sheets.
4. These specification sheets include materials protected under copyright of EVERLIGHT. Reproduction in any form is prohibited without the specific consent of EVERLIGHT.
5. This product is not intended to be used for military, aircraft, automotive, medical, life sustaining or life saving applications or any other application which can result in human injury or death. Please contact authorized Everlight sales agent for special application request.
6. Statements regarding the suitability of products for certain types of applications are based on Everlight's knowledge of typical requirements that are often placed on Everlight products in generic applications. Such statements are not binding statements about the suitability of products for a particular application. It is the customer's responsibility to validate that a particular product with the properties described in the product specification is suitable for use in a particular application. Parameters provided in datasheets and/or specifications may vary in different applications and performance may vary over time. All operating parameters, including typical parameters, must be validated for each customer application by the customer's technical experts. Product specifications do not expand or otherwise modify Everlight's terms and conditions of purchase, including but not limited to the warranty expressed therein.