

4 PIN DIP PHOTOTRANSISTOR PHOTOCOUPLER EL817(D)-G Series

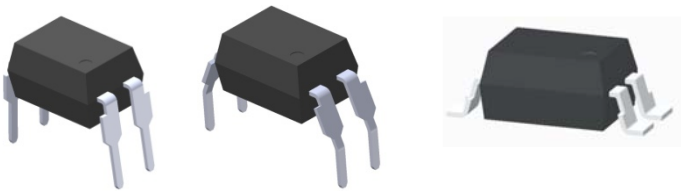

Schematic

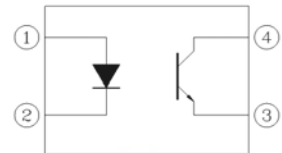

Pin Configuration

1. Anode
2. Cathode
3. Emitter
4. Collector

Features:

- Compliance Halogens Free (Br < 900 ppm, Cl < 900 ppm, Br+Cl < 1500 ppm)
- Current transfer ratio (CTR: 50~600% at $I_F = 5\text{mA}$, $V_{CE} = 5\text{V}$)
- High isolation voltage between input and output (Viso = 5000 V rms)
- Creepage distance > 7.62 mm
- Operating temperature up to +110°C
- Compact small outline package
- Pb free
- Compliance with EU REACH
- The product itself will remain within RoHS compliant version
- UL and cUL approved (No. E214129)
- VDE approved (No. 132249)
- SEMKO approved
- NEMKO approved
- DEMKO approved
- FIMKO approved
- CQC approved

Description

The EL817(D)-G series of devices each consist of an infrared emitting diodes, optically coupled to a phototransistor detector encapsulated with green compound. The devices are in a 4-pin DIP package and available in wide-lead spacing and SMD option.

Applications

- Programmable controllers
- System appliances, measuring instruments
- Telecommunication equipments
- Home appliances, such as fan heaters, etc
- Signal transmission between circuits of different potentials and impedances

Absolute Maximum Ratings (Ta=25°C)

	Parameter	Symbol	Rating	Unit
Input	Forward current	I _F	60	mA
	Peak forward current (1us, pulse)	I _{FP}	1	A
	Reverse voltage	V _R	6	V
	Power Dissipation	P _D	100	mW
	Derating factor (above Ta=100°C)		2.9	mW/°C
Output	Break Down Voltage	P _C	150	mW
	Derating factor (above Ta=100°C)		5.8	mW/°C
	Collector current	I _C	50	mA
	Collector-Emitter voltage	V _{CEO}	80	V
	Emitter-Collector voltage	V _{ECO}	7	V
Total Power Dissipation		P _{TOT}	200	mW
Isolation Voltage*1		V _{ISO}	5000	V rms
Operating Temperature		T _{OPR}	-55 to 110	°C
Storage Temperature		T _{STG}	-55 to 125	°C
Soldering Temperature*2		T _{SOL}	260	°C

Notes

*1 AC for 1 minute, R.H.= 40 ~ 60% R.H. In this test, pins 1, 2 are shorted together, and pins 3, 4 are shorted together.

*2 For 10 seconds

Electro-Optical Characteristics (Ta=25°C unless specified otherwise)

Input

Parameter	Symbol	Min.	Typ.	Max.	Unit	Condition
Forward Voltage	V _F	-	1.2	1.4	V	I _F = 20mA
Reverse Current	I _R	-	-	10	μA	V _R = 4V
Input capacitance	C _{in}	-	30	250	pF	V = 0, f = 1kHz

Note: Reverse Voltage(V_R) Condition is applied to I_R test only The device is not designed for reverse operation

Output

Parameter	Symbol	Min	Typ.	Max.	Unit	Condition
Collector-Emitter dark current	I _{CEO}	-	-	100	nA	V _{CE} = 20V, I _F = 0mA
Collector-Emitter breakdown voltage	BV _{CEO}	80	-	-	V	I _C = 0.1mA
Emitter-Collector breakdown voltage	BV _{ECO}	7	-	-	V	I _E = 0.1mA

Transfer Characteristics

Parameter	Symbol	Min	Typ.	Max.	Unit	Condition	
Current Transfer ratio	EL817A	80	-	160	%	I _F = 5mA, V _{CE} = 5V	
	EL817B	130	-	260			
	EL817C	200	-	400			
	EL817D	300	-	600			
	EL817U	CTR	150	-			200
	EL817X		100	-			200
	EL817Y		150	-			300
	EL817J		63	-			125
		22	-	-		I _F = 10mA, V _{CE} = 5V I _F = 1mA, V _{CE} = 5V	
Collector-Emitter saturation voltage	V _{CE(sat)}	-	0.1	0.2	V	I _F = 20mA, I _C = 1mA	
Isolation resistance	R _{IO}	5×10 ¹⁰	-	-	Ω	V _{IO} = 500Vdc, 40~60% R.H.	
Floating capacitance	C _{IO}	-	0.6	1.0	pF	V _{IO} = 0, f = 1MHz	
Cut-off frequency	f _c	-	80	-	kHz	V _{CE} = 5V, I _C = 2mA R _L = 100Ω, -3dB	
Turn on time	T _{on}	-	5	-	μs		
Turn off time	T _{off}	-	6	-	μs		
Rise time	t _r	-	-	18	μs	V _{CE} = 2V, I _C = 2mA, R _L = 100Ω	
Fall time	t _f	-	-	18	μs		

* Typical values at T_a = 25°C

Typical Electro-Optical Characteristics Curves

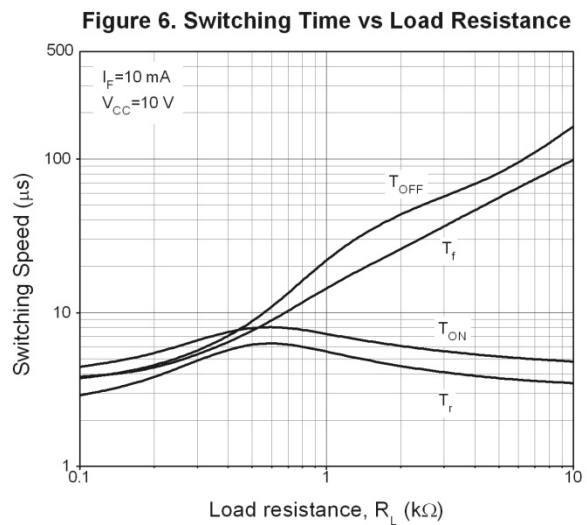
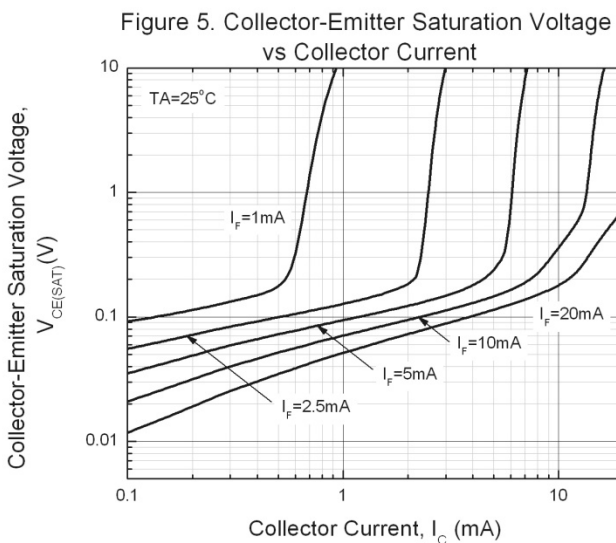
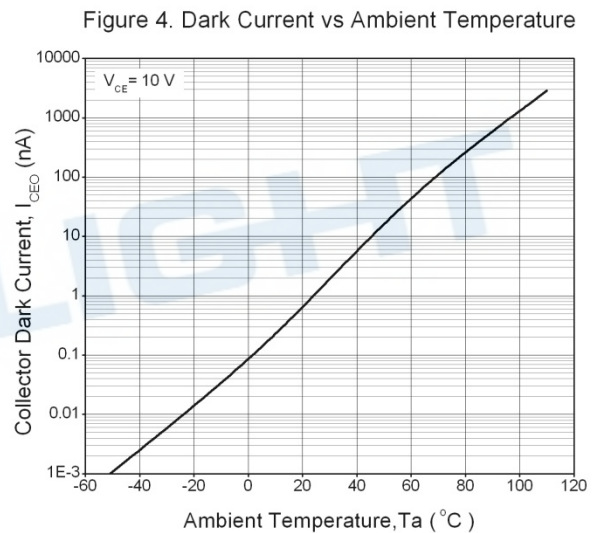
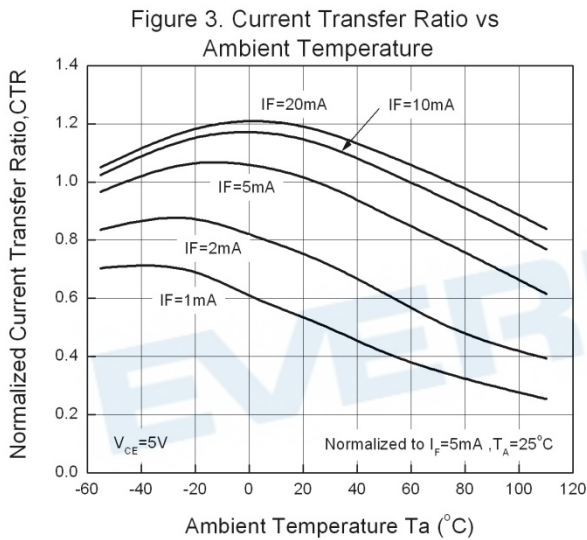
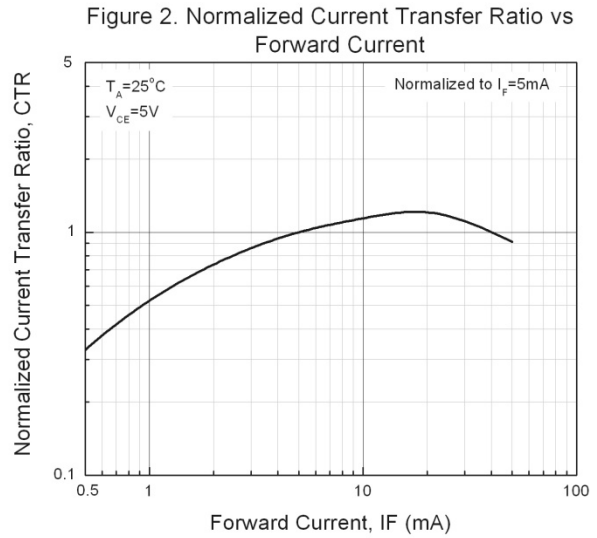
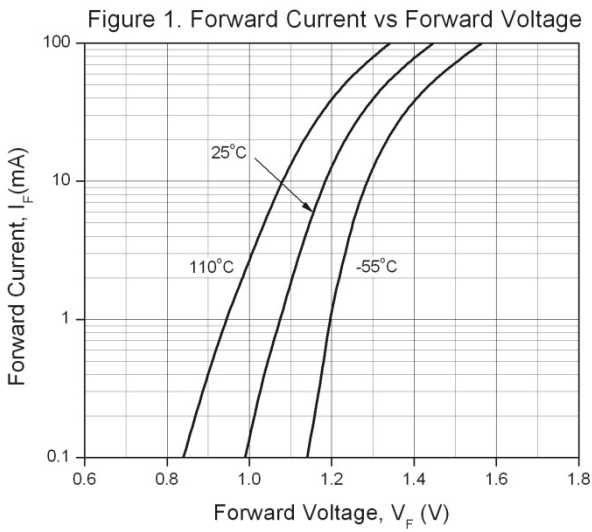

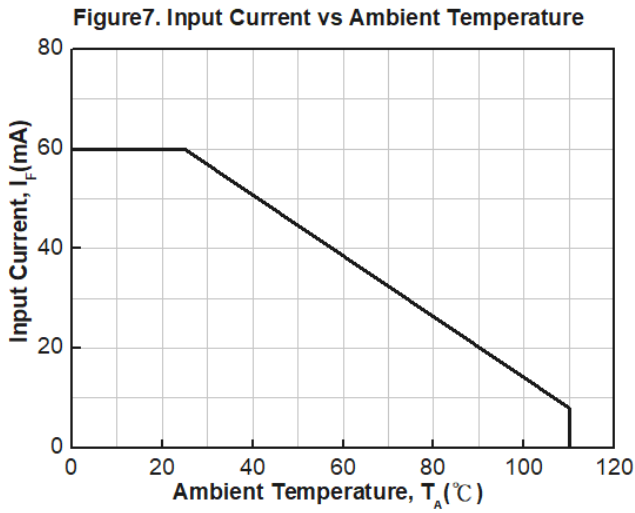

Note: The graphs shown in this datasheet are representing typical data only and do not show guaranteed values

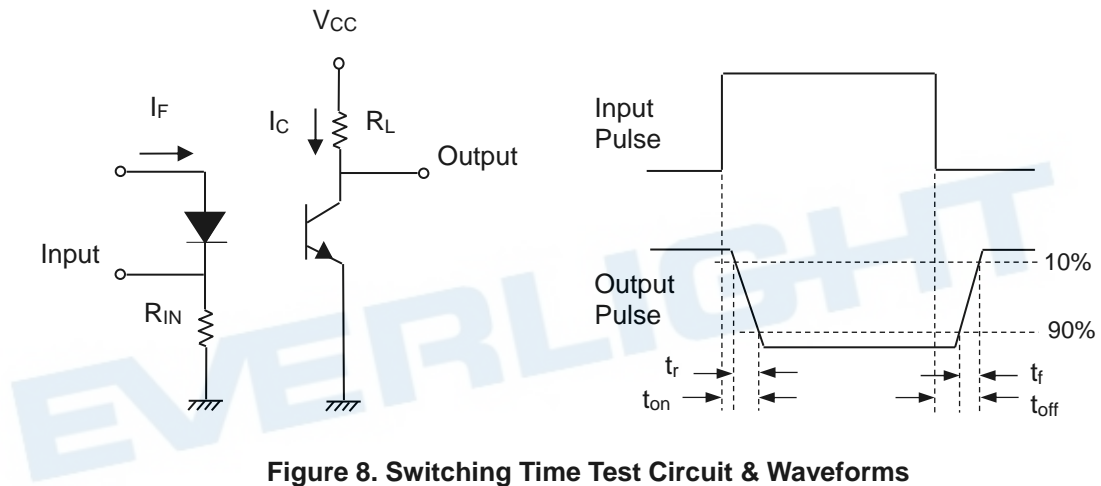

Figure 8. Switching Time Test Circuit & Waveforms

Order Information

Part Number

EL817X(Y)(Z)(D)-FVG

Note

- X = Lead form option (S, S1, M or none)
- Y = CTR Rank (A, B, C, D, U, X, Y, J, or none))
- Z = Tape and reel option (TU, TD , TA ,TB, or none)
- D = Customer code
- F = Lead frame option (F: Iron, None: copper)
- V = VDE safety (optional).
- G = Halogen free

Option	Description	Packing quantity
None	Standard DIP-4	100 units per tube
M	Wide lead bend (0.4 inch spacing)	100 units per tube
S (TU)	Surface mount lead form + TU tape & reel option	1500 units per reel
S (TD)	Surface mount lead form + TD tape & reel option	1500 units per reel
S1 (TU)	Surface mount lead form (low profile) + TU tape & reel option	1500 units per reel
S1 (TD)	Surface mount lead form (low profile) + TD tape & reel option	1500 units per reel
S1 (TA)	Surface mount lead form (low profile) + TA tape & reel option	1000 units per reel
S1 (TB)	Surface mount lead form (low profile) + TB tape & reel option	1000 units per reel

Package Dimension (Dimensions in mm)

Standard DIP Type

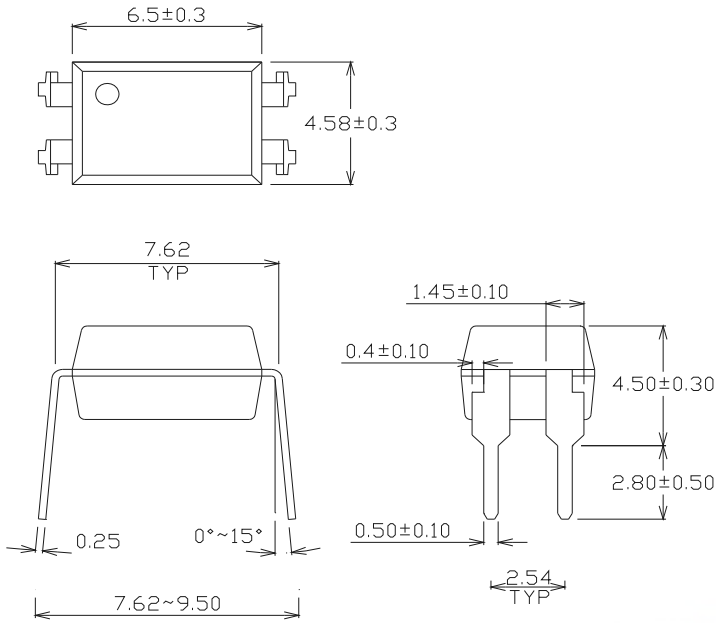

Option M Type

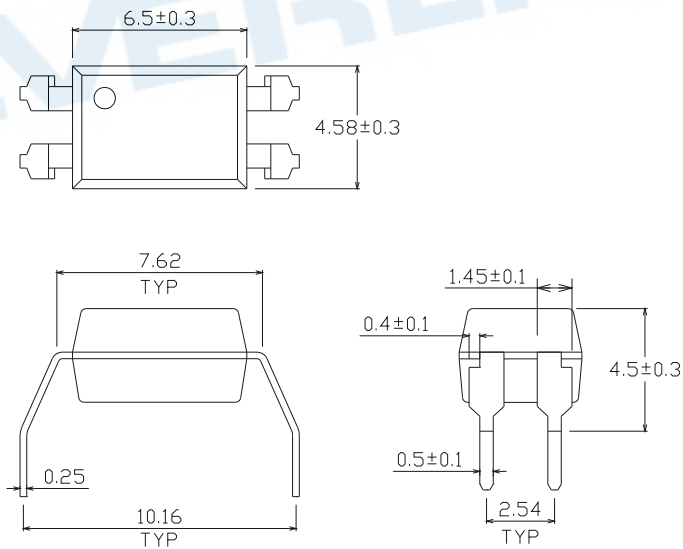

Option S Type

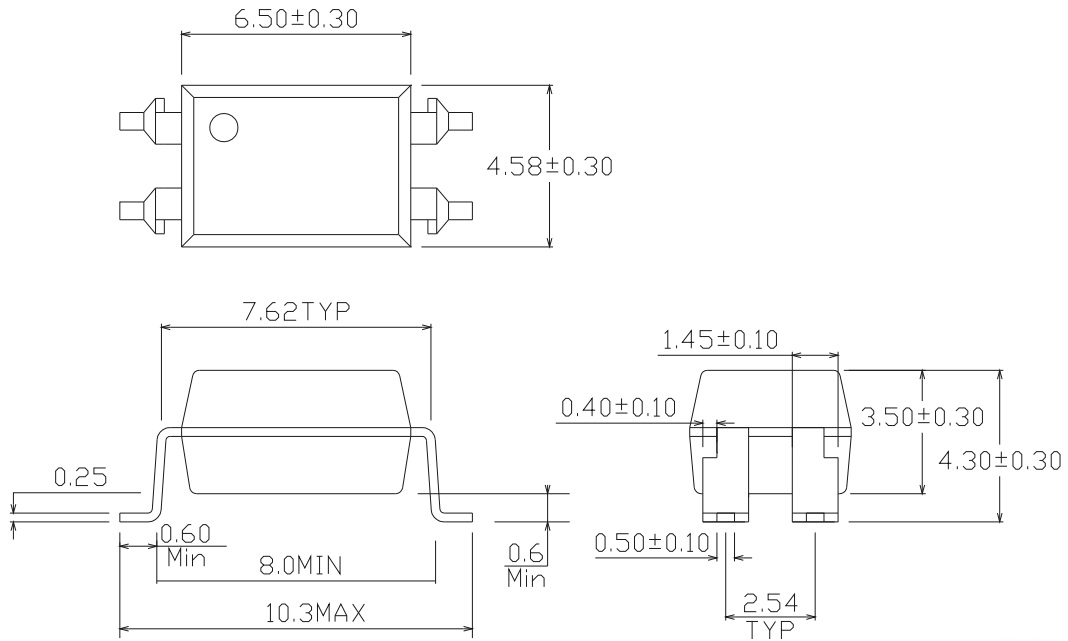

Option S1 Type

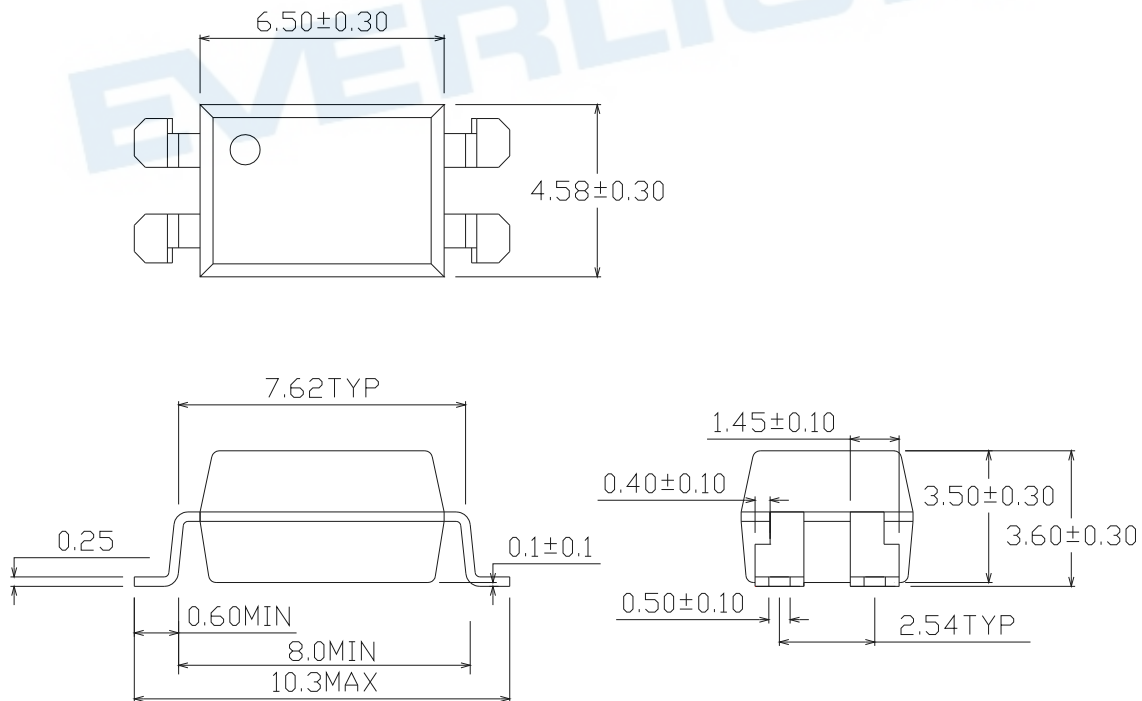

Recommended pad layout for surface mount leadform

For S option

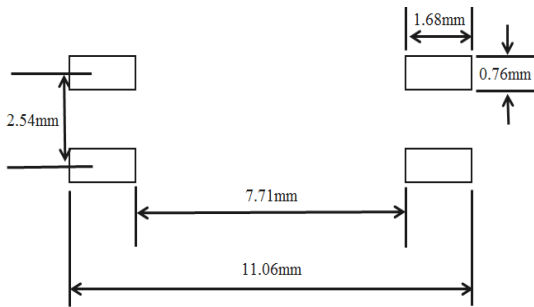

For S1 option

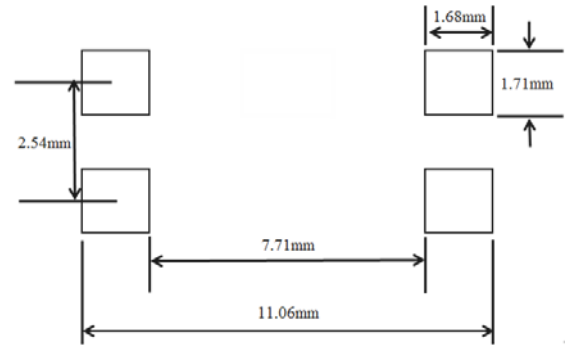

Notes

Suggested pad dimension is just for reference only.
 Please modify the pad dimension based on individual need.

Device Marking





Notes

- EL denotes EVERLIGHT
- 817 denotes Device Number
- G denotes Green part
- R denotes CTR Rank (A, B, C, D, U, X, Y, J, or none)
- Y denotes 1 digit Year code
- WW denotes 2 digit Week code
- V denotes VDE

Label form

EVERLIGHT
11 → 月份



客戶料號 ← CPN: XXXXXXXXXXXX 測試區
  → RoHS標示

億光料號 ← P/N: XXXXXXXXXXXX
  → 安規標示

億光品名 ← EL817M(C)-VG





生產週別 ← D/C: YWWX CAT: X QTY: 000000

 REF: XXXX  → 包裝數量

生產序號 ← LOT NO: Y151130XXXXXXXXXX

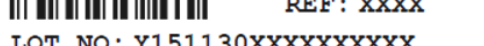

標籤識別碼 ← REFERENCE: BTPyyMMddXXXXX



 → QR Code

產地 ← MADE IN XXXXXX

OR

RoHS 標示



EVERLIGHT
5 → 月份

客戶料號 ← CPN: XXXXXXXXXXXX 測試區
  → 安規標示

客戶品名 ← XXXXXXXXXXX-XXXXXXXXXX-XXXXXXXXXX-XXXXXXXXXX-XXXXXX



億光料號 ← P/N: XXXXXXXXXXXX



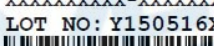

億光品名 ← XXXXXXXXXXX-XXXXXXXXXX-XXXXXXXXXX-XXXXXX



生產序號 ← LOT NO: Y150516XXX-XXXXXXXXXX-XXXXXXXXXX





包裝數量 ← QTY: 0123456789 HUE: XXXXXXXXXXXX

CTR等級 ← CAT: XXXXXXXXXXXX REF: XXXXXXXXXXXX

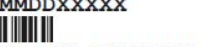
標籤識別碼 ← REFERENCE: BTPYMMDDXXXXX

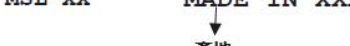

 → QR Code

MSL等級 ← MSL-XX MADE IN XXXXXX

↓

 產地

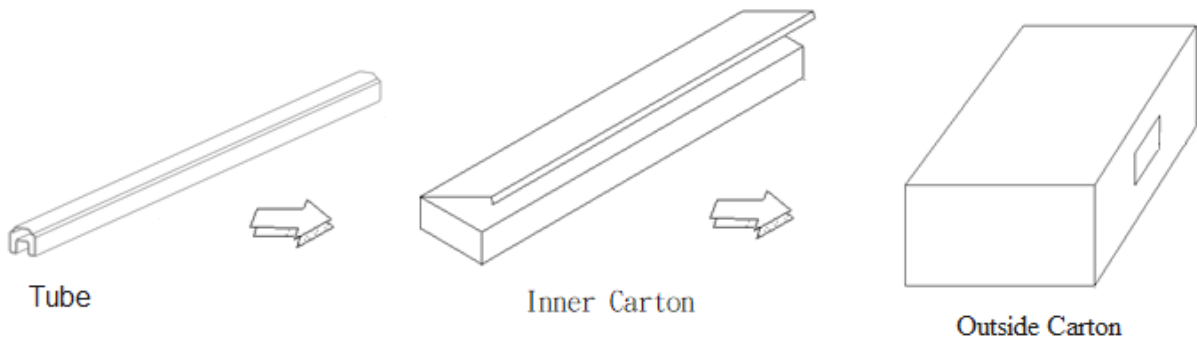
TUBE Dimension



Reel Dimension

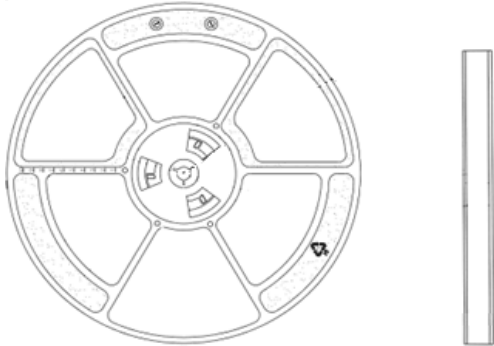

Moisture Resistant Packaging

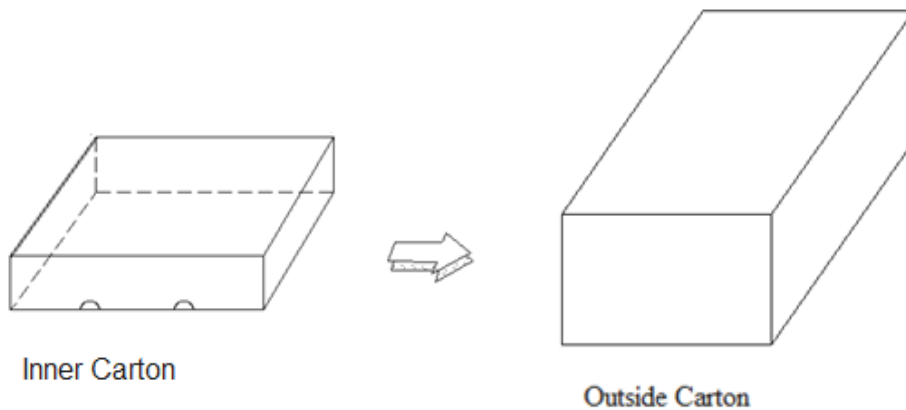
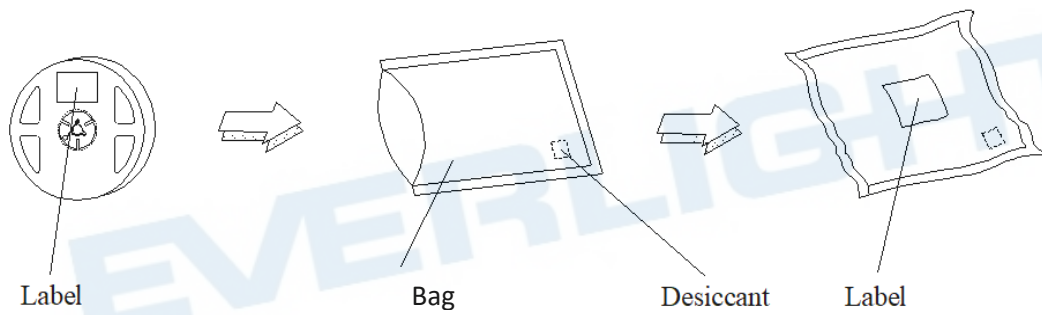

Tape & Reel Packing Specifications

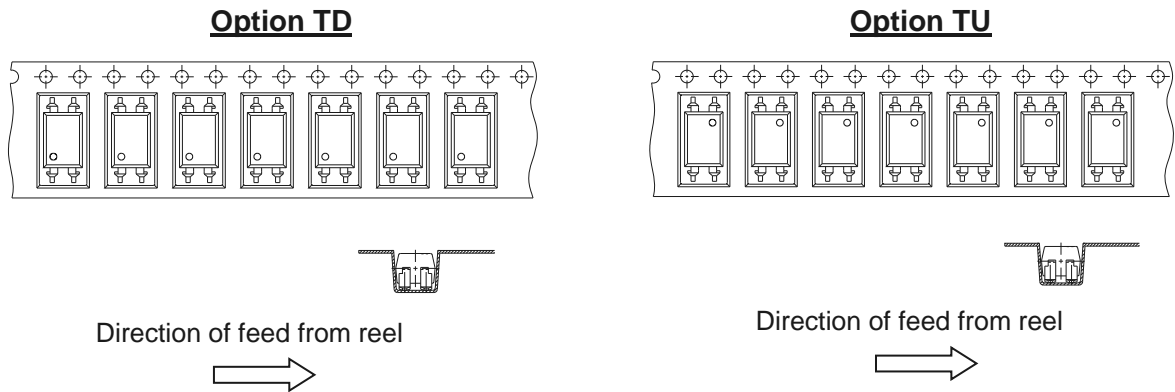

Tape dimensions

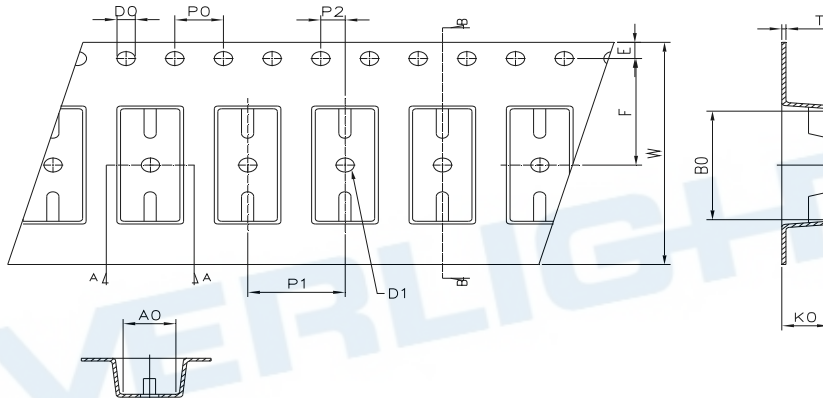

Dimension No.	Ao	Bo	Do	D1	E	F
Dimension (mm) S	4.90±0.1	10.40±0.1	1.5+0.1/-0	1.50+0.1/-0	1.75±0.1	7.50±0.1
Dimension (mm) S1	4.90±0.1	10.40±0.1	1.5+0.1/-0	1.50+0.1/-0	1.75±0.1	7.50±0.1
Dimension No.	Po	P1	P2	t	W	Ko
Dimension (mm) S	4.00±0.1	8.00±0.1	2.00±0.1	0.48±0.05	16.00±0.2	4.6±0.1
Dimension (mm) S1	4.00±0.1	8.00±0.1	2.00±0.1	0.48±0.05	16.00±0.2	4.6±0.1

Tape & Reel Packing Specifications

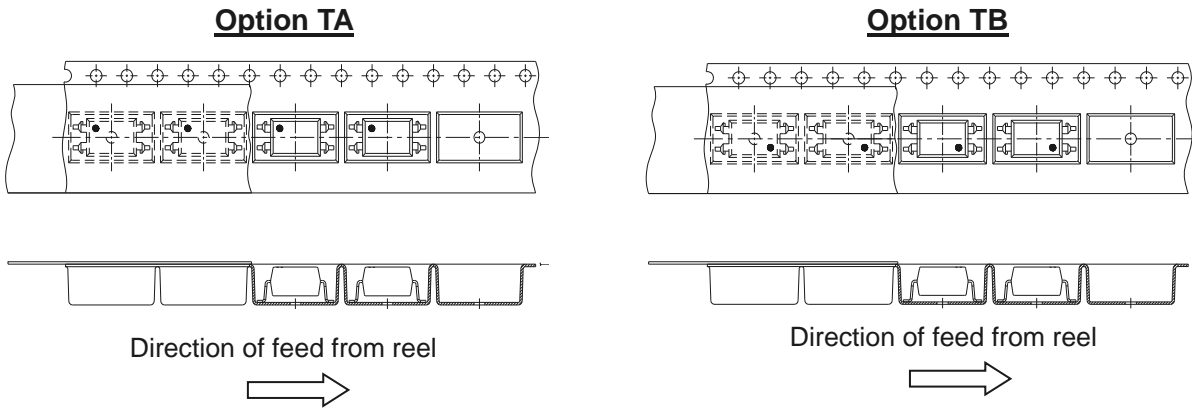

Tape dimensions

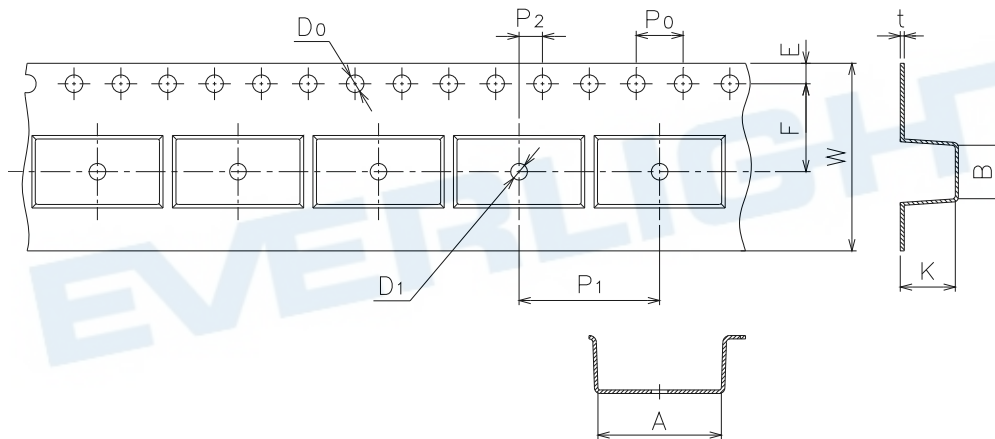

Dimension No.	A	B	Do	D1	E	F
Dimension (mm) S1	10.7±0.1	4.65±0.1	1.55±0.05	1.50+0.1/-0	1.75±0.1	7.5±0.1
Dimension (mm) S2	12.5±0.1	4.65±0.1	1.55±0.05	1.50+0.1/-0	1.75±0.1	7.5±0.1
Dimension No.	P0	P1	P2	t	W	K
Dimension (mm) S1	4.0±0.1	12.0±0.1	2.0±0.1	0.4±0.05	16.0±0.2	3.90±0.1
Dimension (mm) S2	4.0±0.1	16.0±0.1	2.0±0.1	0.4±0.05	16.0±0.2	3.90±0.1

Precautions for Use

1. Soldering Condition

1.1 (A) Maximum Body Case Temperature Profile for evaluation of Reflow Profile

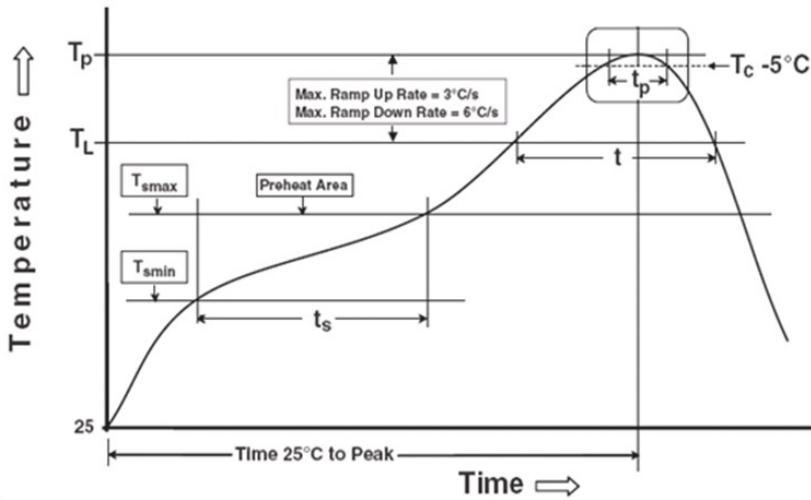

Note

Reference: IPC/JEDEC J-STD-020D

Preheat

Temperature min (T_{smin})	150 °C
Temperature max (T_{smax})	200°C
Time (T_{smin} to T_{smax}) (t_s)	60-120 seconds
Average ramp-up rate (T_{smax} to T_p)	3 °C/second max

Other

Liquidus Temperature (T_L)	217 °C
Time above Liquidus Temperature (t_L)	60-100 sec
Peak Temperature (T_p)	260°C
Time within 5 °C of Actual Peak Temperature: $T_p - 5^\circ\text{C}$	30 s
Ramp- Down Rate from Peak Temperature	6°C /second max.
Time 25°C to peak temperature	8 minutes max.
Reflow times	3 times

Wave solder Temperature profile

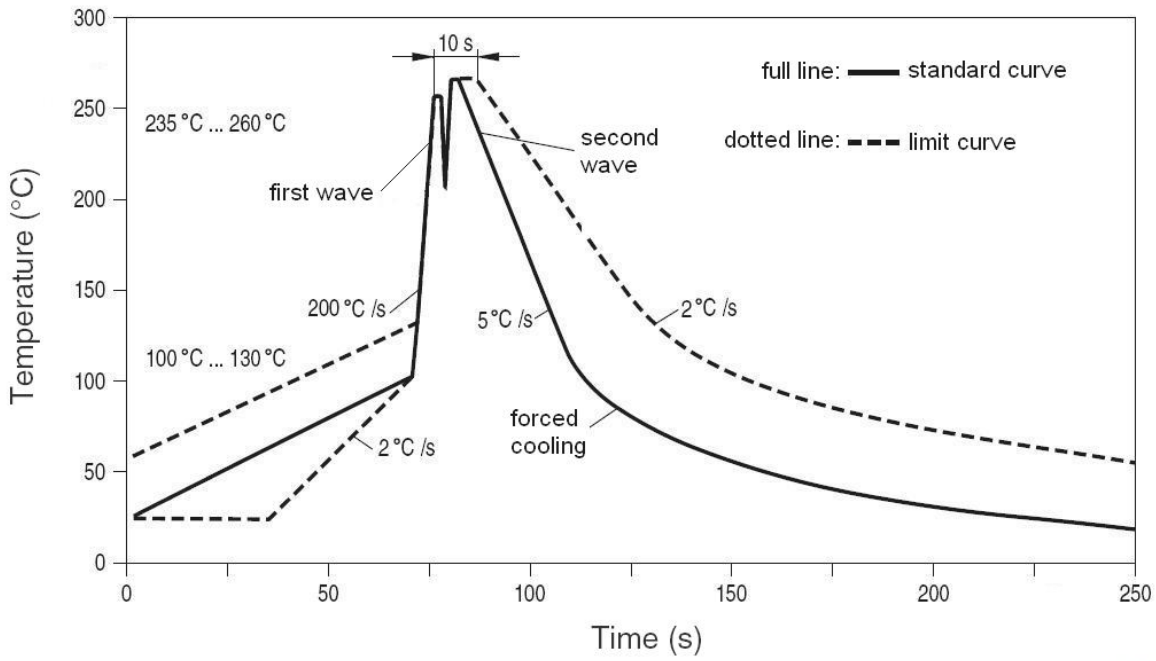

EVERLIGHT

Precautions for General Storage

- Avoid storage locations where devices may be exposed to moisture or direct sunlight.
- Follow the precautions printed on the packing label of the device for transportation and storage.
- Keep the storage location temperature and humidity within a range of 5°C to 35°C and 20 % to 60 %, respectively.
- Do not store the products in locations with poisonous gases (especially corrosive gases) or in dusty conditions.
- Store the products in locations with minimal temperature fluctuations. Rapid temperature changes during storage can cause condensation, resulting in lead oxidation or corrosion, which will deteriorate the solderability of the leads.
- When restoring devices after removal from their packing, use anti-static containers.
- Do not allow loads to be applied directly to devices while they are in storage.
- If devices have been stored for more than two years under normal storage conditions, it is recommended that you check the leads for ease of soldering prior to use.

EVERLIGHT

DISCLAIMER

1. Above specification may be changed without notice. EVERLIGHT will reserve authority on material change for above specification.
2. The graphs shown in this datasheet are representing typical data only and do not show guaranteed values.
3. When using this product, please observe the absolute maximum ratings and the instructions for use outlined in these specification sheets. EVERLIGHT assumes no responsibility for any damage resulting from use of the product which does not comply with the absolute maximum ratings and the instructions included in these specification sheets.
4. These specification sheets include materials protected under copyright of EVERLIGHT. Reproduction in any form is prohibited without the specific consent of EVERLIGHT.
5. This product is not intended to be used for military, aircraft, automotive, medical, life sustaining or life saving applications or any other application which can result in human injury or death. Please contact authorized Everlight sales agent for special application request.
6. Statements regarding the suitability of products for certain types of applications are based on Everlight's knowledge of typical requirements that are often placed on Everlight products in generic applications. Such statements are not binding statements about the suitability of products for a particular application. It is the customer's responsibility to validate that a particular product with the properties described in the product specification is suitable for use in a particular application. Parameters provided in datasheets and/or specifications may vary in different applications and performance may vary over time. All operating parameters, including typical parameters, must be validated for each customer application by the customer's technical experts. Product specifications do not expand or otherwise modify Everlight's terms and conditions of purchase, including but not limited to the warranty expressed therein.