

4 PIN DIP PHOTODARLINGTON PHOTOCOUPLER EL815 Series

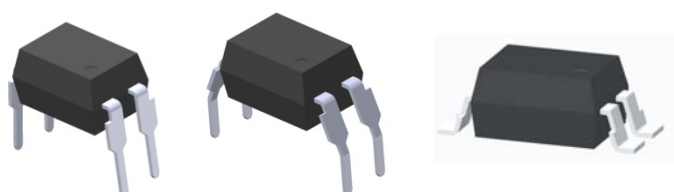

Schematic

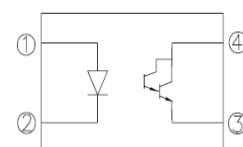

Pin Configuration

1. Anode
2. Cathode
3. Emitter
4. Collector

Features:

- Compliance Halogens Free
(Br < 900 ppm, Cl < 900 ppm, Br+Cl < 1500 ppm)
- Current transfer ratio
(CTR: 600~7500% at $I_F = 1\text{mA}$, $V_{CE} = 2\text{V}$)
- High isolation voltage between input and output (Viso=5000 V rms)
- Creepage distance >7.62 mm
- Operating temperature up to +110°C
- Compact small outline package
- Pb free
- The product itself will remain within RoHS compliant version
- Compliance with EU REACH
- UL approved (No. E214129)
- VDE approved (No. 132249)
- UL and cUL approved(No. E214129)
- SEMKO approved
- NEMKO approved
- DEMKO approved
- FIMKO approved
- CQC approved

Description

The EL815 series of devices each consist of an infrared emitting diodes, optically coupled to a photo Darlington detector.

They are packaged in a 4-pin DIP package and available in wide-lead spacing and SMD option.

Applications

- Telephone set, telephone exchangers
- Sequence controllers
- System appliances, measuring instruments
- Signal transmission between circuits of different potentials and impedances

Absolute Maximum Ratings (Ta=25°C)

| | Parameter | Symbol | Rating | Unit |
|-------------------------|---------------------------------------|------------------|------------|-------|
| Input | Forward current | I _F | 60 | mA |
| | Peak forward current (1us, pulse) | I _{FP} | 1 | A |
| | Reverse voltage | V _R | 6 | V |
| | Power dissipation | P _D | 100 | mW |
| | No derating required up to Ta = 100°C | | | |
| Output | Power dissipation | P _C | 150 | mW |
| | Derating factor (above Ta = 80°C) | | 5.8 | mW/°C |
| | Collector current | I _C | 80 | mA |
| | Collector-Emitter voltage | V _{CEO} | 35 | V |
| | Emitter-Collector voltage | V _{ECO} | 7 | V |
| Total power dissipation | | P _{TOT} | 200 | mW |
| Isolation voltage *1 | | V _{ISO} | 5000 | V rms |
| Operating temperature | | T _{OPR} | -55 ~ +110 | °C |
| Storage temperature | | T _{STG} | -55 ~ +125 | °C |
| Soldering Temperature*2 | | T _{SOL} | 260 | °C |

Notes:

*1 AC for 1 minute, R.H.= 40 ~ 60% R.H. In this test, pins 1 & 2 are shorted together, and pins 3 & 4 are shorted together.

*2 For 10 seconds

Electro-Optical Characteristics (Ta=25°C unless specified otherwise)

Input

| Parameter | Symbol | Min. | Typ.* | Max. | Unit | Condition |
|-------------------|-----------------|------|-------|------|------|-----------------------|
| Forward Voltage | V _F | - | 1.2 | 1.4 | V | I _F = 20mA |
| Reverse Current | I _R | - | - | 10 | μA | V _R = 4V |
| Input capacitance | C _{in} | - | 30 | 250 | pF | V = 0, f = 1kHz |

Note: Reverse Voltage(V_R) Condition is applied to I_R test only The device is not designed for reverse operation

Output

| Parameter | Symbol | Min. | Typ.* | Max. | Unit | Condition |
|-------------------------------------|-------------------|------|-------|------|------|---|
| Collector-Emitter dark current | I _{CEO} | - | - | 1 | μA | V _{CE} = 10V, I _F = 0mA |
| Collector-Emitter breakdown voltage | BV _{CEO} | 35 | - | - | V | I _C = 0.1mA |
| Emitter-Collector breakdown voltage | BV _{ECO} | 7 | - | - | V | I _E = 0.1mA |

Transfer Characteristics

| Parameter | Symbol | Min. | Typ.* | Max. | Unit | Condition |
|--------------------------------------|----------------------|--------------------|-------|------|------|---|
| Current Transfer ratio | CTR | 600 | - | 7500 | % | I _F = 1mA, V _{CE} = 2V |
| Collector-Emitter saturation voltage | V _{CE(sat)} | - | 0.8 | 1.0 | V | I _F = 20mA, I _C = 5mA |
| Isolation resistance | R _{IO} | 5×10 ¹⁰ | - | - | Ω | V _{IO} = 500Vdc, 40~60% R.H. |
| Floating capacitance | C _{IO} | - | 0.6 | 1.0 | pF | V _{IO} = 0, f = 1MHz |
| Cut-off frequency | f _c | - | 6 | - | kHz | V _{CE} = 5V, I _C = 2mA R _L = 100Ω, -3dB |
| Rise time | t _r | - | 60 | 300 | μs | V _{CE} = 2V, I _C = 10mA, R _L = 100Ω |
| Fall time | t _f | - | 53 | 250 | μs | |

* Typical values at T_a = 25°C

Typical Electro-Optical Characteristics Curves

Figure 1. Forward Current vs Forward Voltage

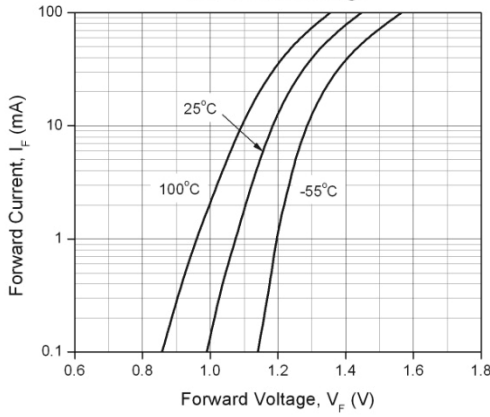

Figure 2. Current Transfer Ratio vs. Ambient Temperature

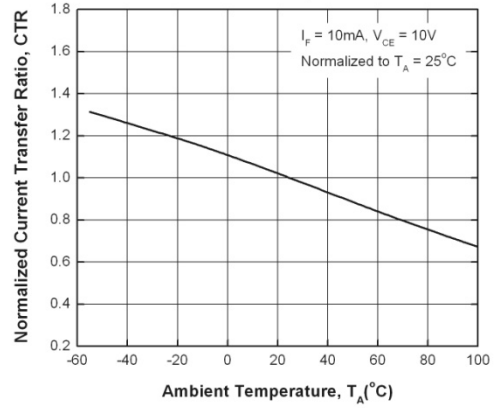

Figure 3. Normalized Current Transfer Ratio vs Forward Current

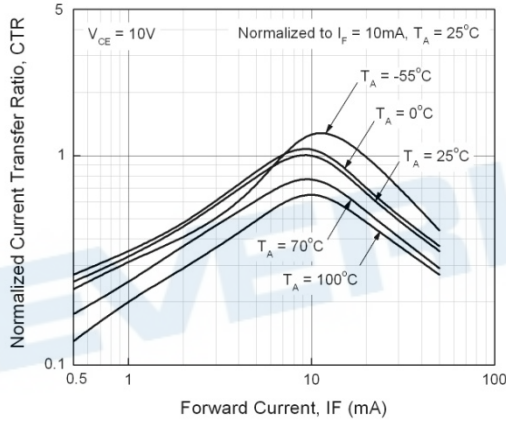

Figure 4. Collector Dark Current vs Ambient Temperature

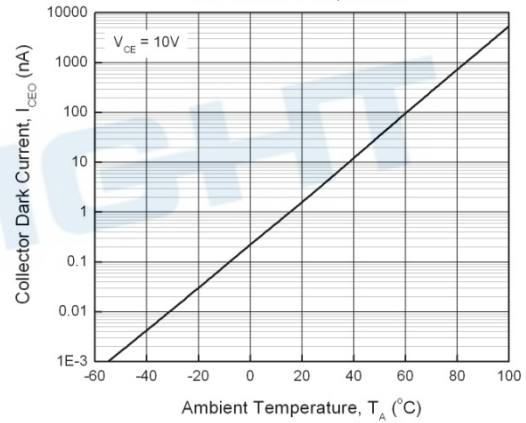

Figure 5. Turn-on Time vs Forward Current

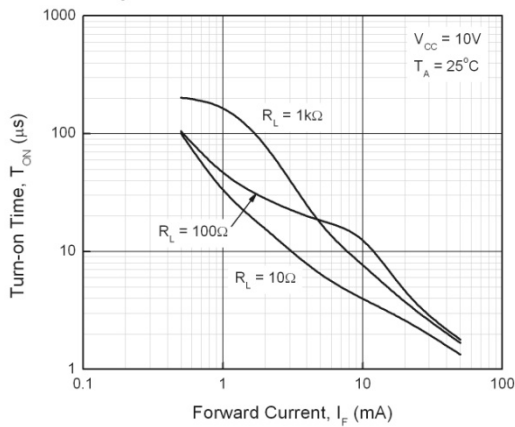
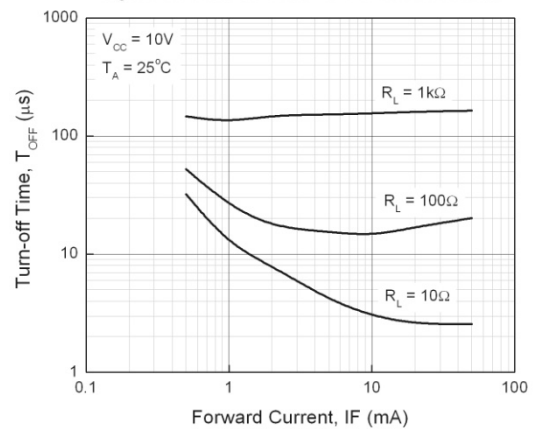

Figure 6. Turn-off Time vs Forward Current



Note: The graphs shown in this datasheet are representing typical data only and do not show guaranteed values

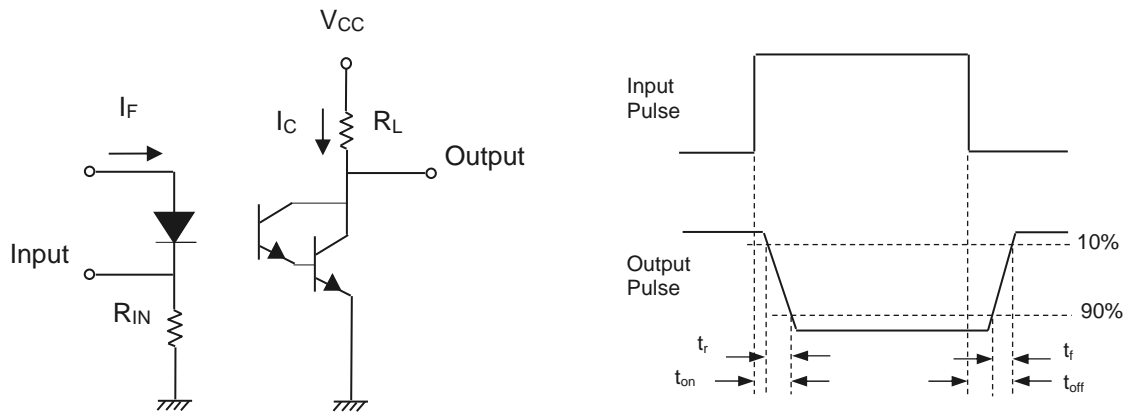

Figure 7. Switching Time Test Circuit & Waveforms

EVERLIGHT

Order Information

Part Number

EL815X(Z)-V

Note

- X = Lead form option (S1, M or none)
- Z = Tape and reel option (TA, TB ,TU, TD or none)
- V = VDE safety (optional)

| Option | Description | Packing quantity |
|---------|---|---------------------|
| None | Standard DIP-4 | 100 units per tube |
| M | Wide lead bend (0.4 inch spacing) | 100 units per tube |
| S1 (TA) | Surface mount lead form (low profile) + TA tape & reel option | 1000 units per reel |
| S1 (TB) | Surface mount lead form (low profile) + TB tape & reel option | 1000 units per reel |
| S1 (TU) | Surface mount lead form (low profile) + TU tape & reel option | 2000 units per reel |
| S1 (TD) | Surface mount lead form (low profile) + TD tape & reel option | 2000 units per reel |

Package Dimension (Dimensions in mm)

Standard DIP Type

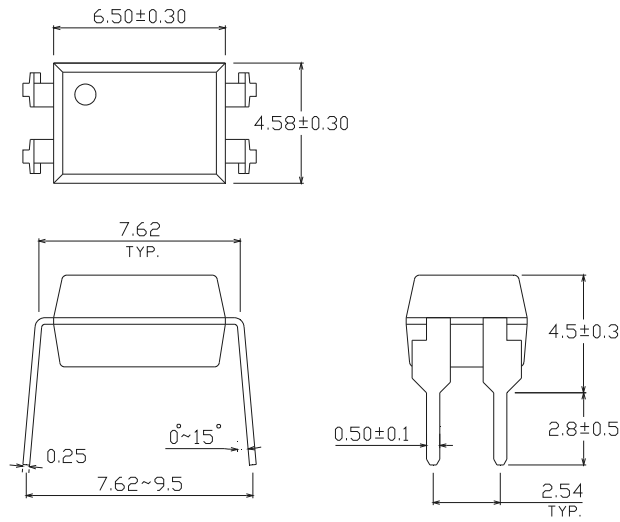

Option M Type

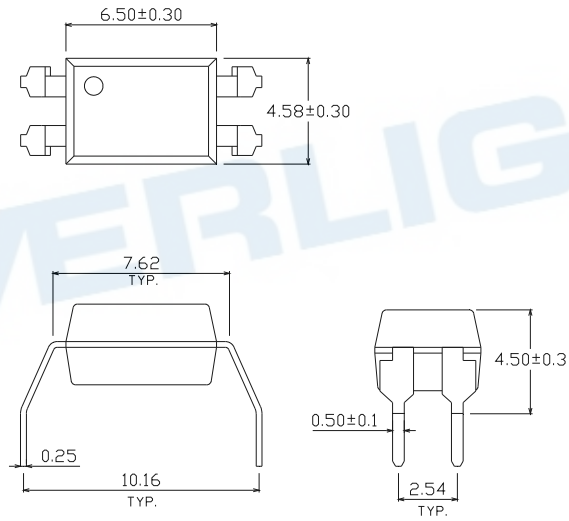

Option S1 Type

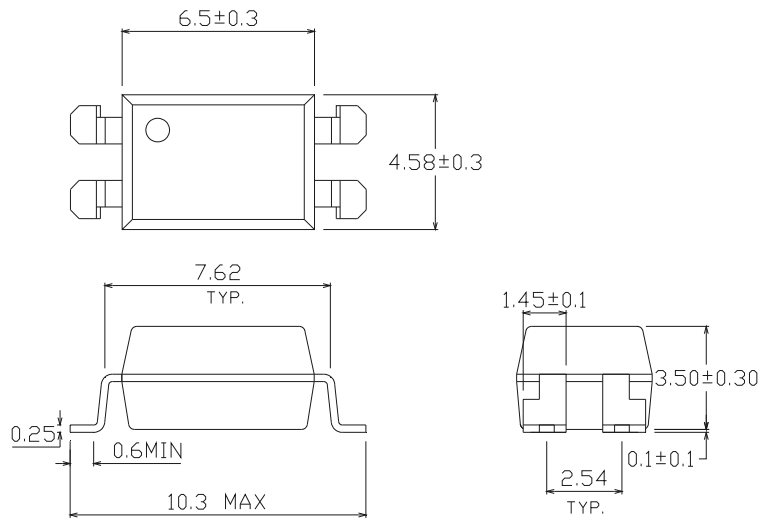

Recommended pad layout for surface mount leadform

For S1 option

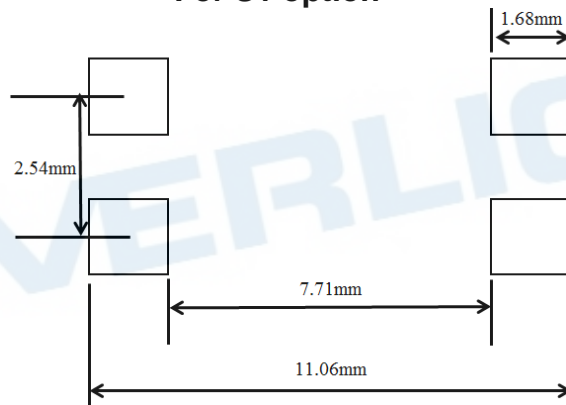

Notes

Suggested pad dimension is just for reference only.
Please modify the pad dimension based on individual need.

Device Marking

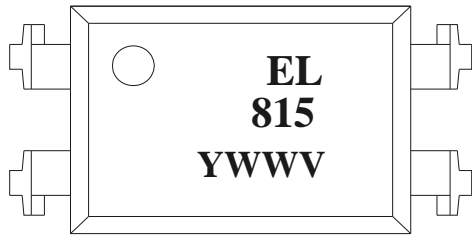



Notes

| | |
|-----|---------------------------|
| EL | denotes EVERLIGHT |
| 815 | denotes Device Number |
| Y | denotes 1 digit Year code |
| WW | denotes 2 digit Week code |
| V | denotes VDE optional |

EVERLIGHT

Label form

EVERLIGHT
11 → 月份



客戶料號 ← CPN: XXXXXXXXXXXX 測試區
  → RoHS標示

億光料號 ← P/N: XXXXXXXXXXXX
  → 安規標示

億光品名 ← EL817M(C)-VG





生產周別 ← D/C: YWWX CAT: X QTY: 000000

 REF: XXXX  → 包裝數量

生產序號 ← LOT NO: Y151130XXXXXXXXXX





標籤識別碼 ← REFERENCE: BTPyyMMddXXXXX

 → QR Code

產地 ← MADE IN XXXXXX

or

 → RoHS 標示
EVERLIGHT
5 → 月份

客戶料號 ← CPN: XXXXXXXXXXXX 測試區
  → 安規標示

客戶品名 ← XXXXXXXXXXX-XXXXXXXXXX-XXXXXXXXXX-XXXXXXXXXX-XXXXXX

 億光料號 ← P/N: XXXXXXXXXXXX



 億光品名 ← XXXXXXXXXXX-XXXXXXXXXX-XXXXXXXXXX-XXXXXX

 生產序號 ← LOT NO: Y150516XXX-XXXXXXXXXX-XXXXXXXXXX



 QTY: 0123456789 HUE: XXXXXXXXXXXX

包裝數量 ←

 CTR等級 ← CAT: XXXXXXXXXXXX REF: XXXXXXXXXXXX

標籤識別碼 ← REFERENCE: BTPYMMDDXXXXX



 → QR Code

MSL等級 ← MSL-XX MADE IN XXXXXX

↓

 產地

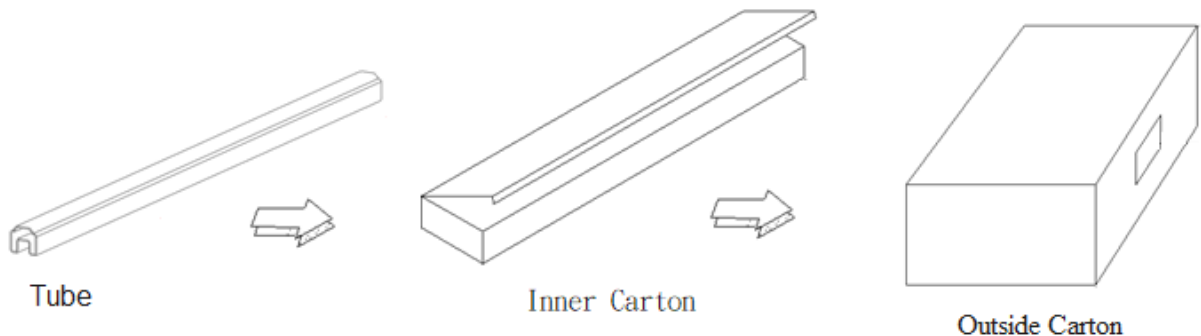
TUBE Dimension



Reel Dimension

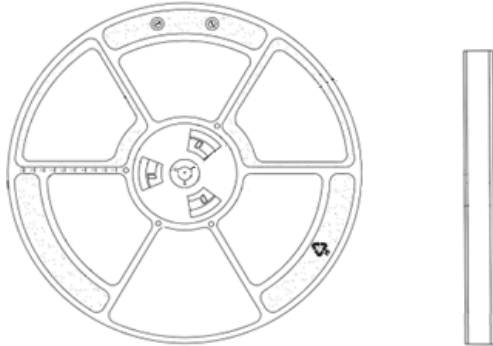

Moisture Resistant Packaging

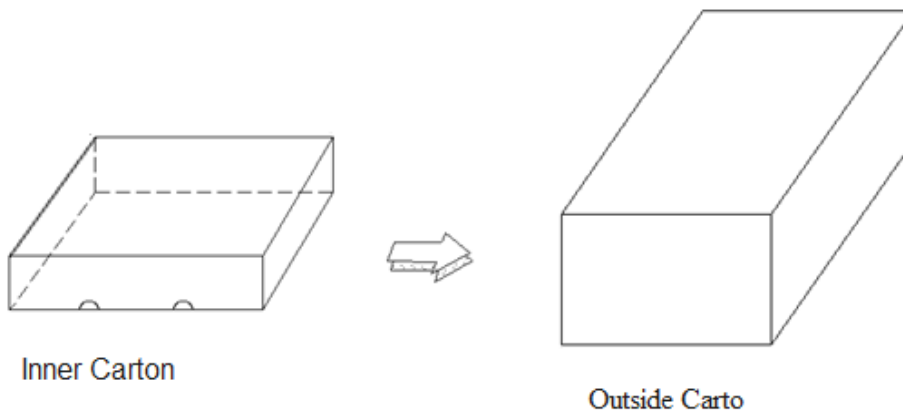
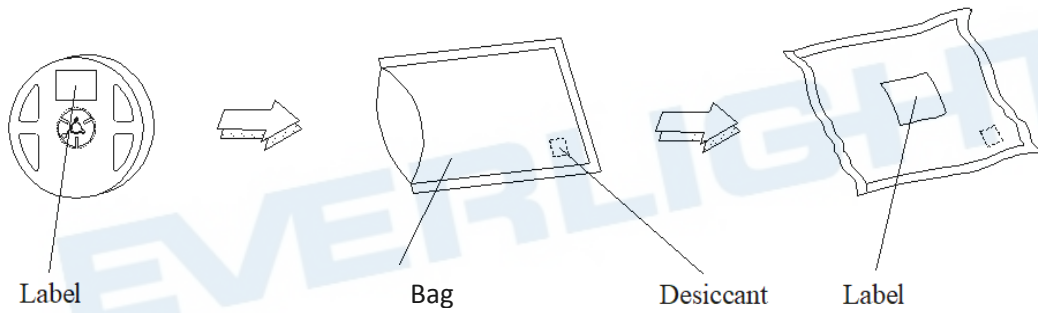

Tape & Reel Packing Specifications

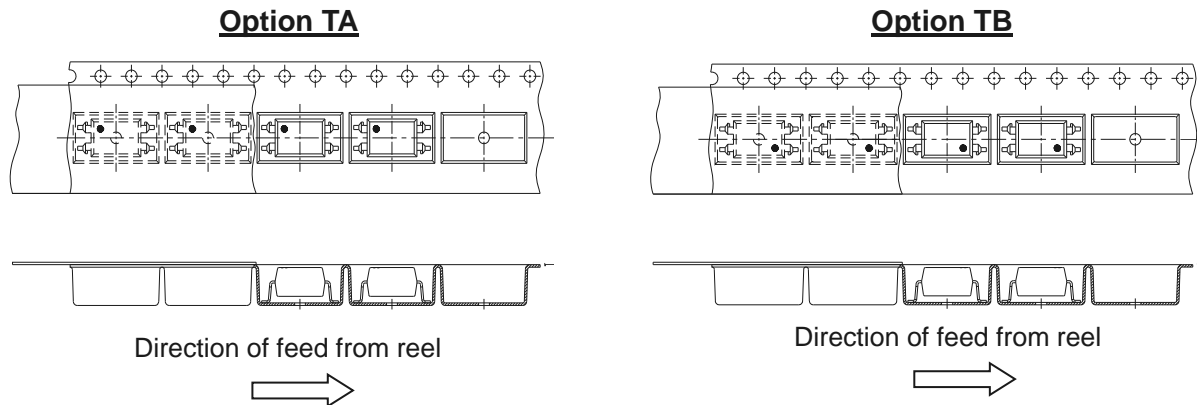

Tape dimensions

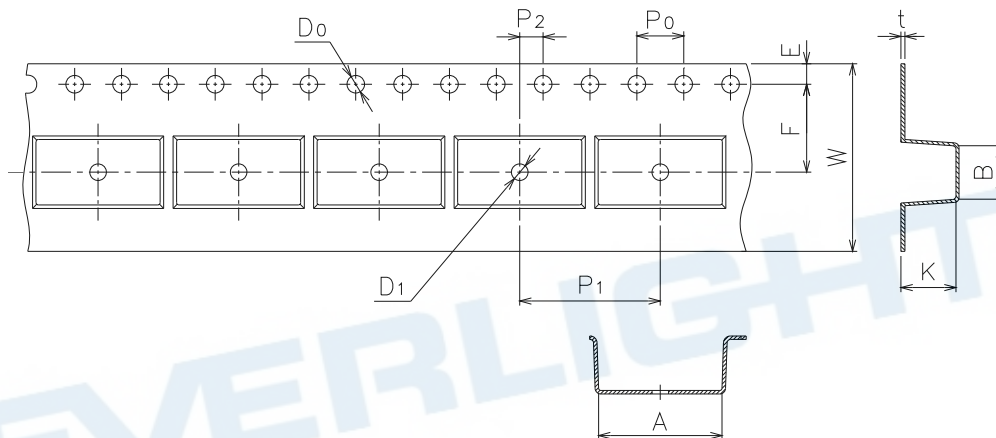

| | | | | | | |
|----------------------|-----------|-----------|-----------|-----------|----------|----------|
| Dimension No. | A | B | Do | D1 | E | F |
| Dimension (mm) S1 | 10.7±0.1 | 4.65±0.1 | 1.5±0.1 | 1.50±0.1 | 1.75±0.1 | 7.5±0.1 |
| Dimension No. | Po | P1 | P2 | t | W | K |
| Dimension (mm) S1 | 4.0±0.1 | 12.0±0.1 | 2.0±0.1 | 0.4±0.1 | 16.0±0.3 | 3.9±0.1 |

Tape & Reel Packing Specifications

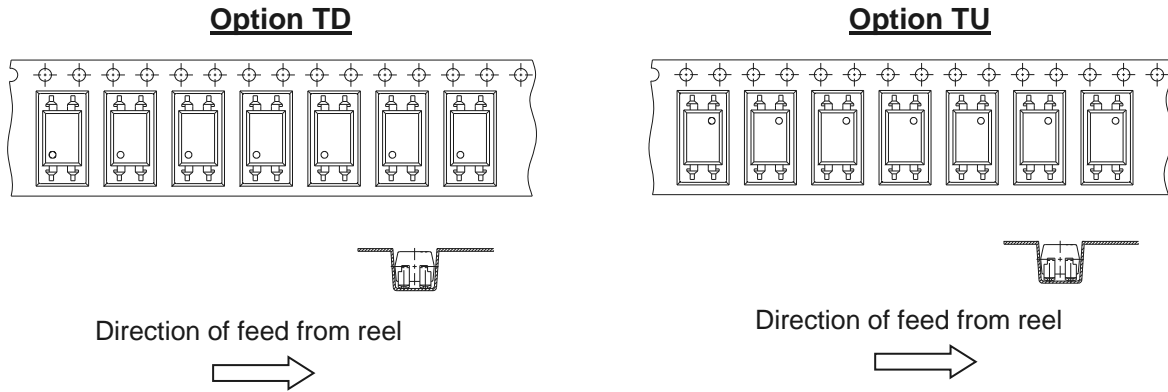

Tape dimensions

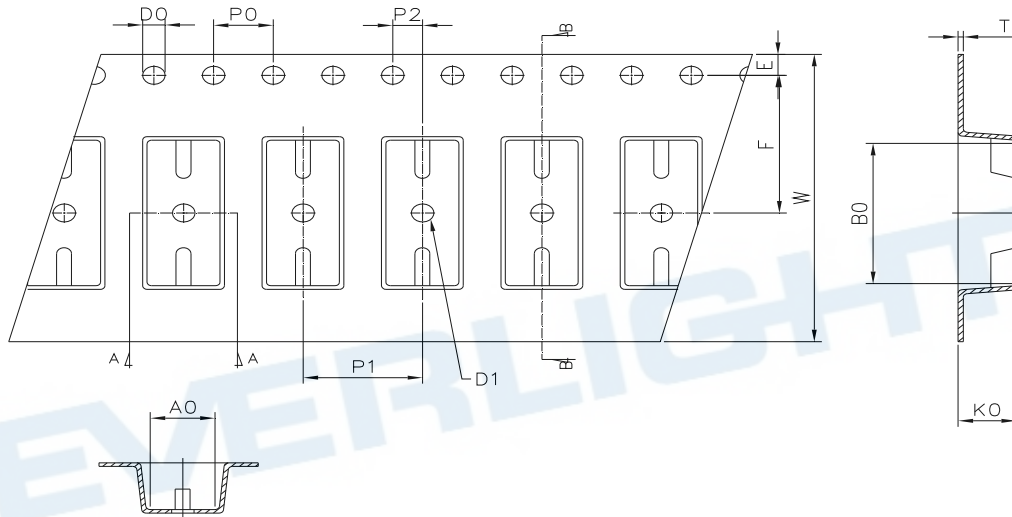

| | | | | | | |
|----------------|-----------|-----------|-----------|-----------|-----------|-----------|
| Dimension No. | Ao | Bo | Do | D1 | E | F |
| Dimension (mm) | 4.90±0.1 | 10.40±0.1 | 1.5±0.1 | 1.50±0.1 | 1.75±0.1 | 7.50±0.1 |
| Dimension No. | Po | P1 | P2 | t | W | Ko |
| Dimension (mm) | 4.00±0.1 | 8.00±0.1 | 2.00±0.1 | 0.40±0.1 | 16.00±0.3 | 4.00±0.1 |

Precautions for Use

1. Soldering Condition

1.1 (A) Maximum Body Case Temperature Profile for evaluation of Reflow Profile

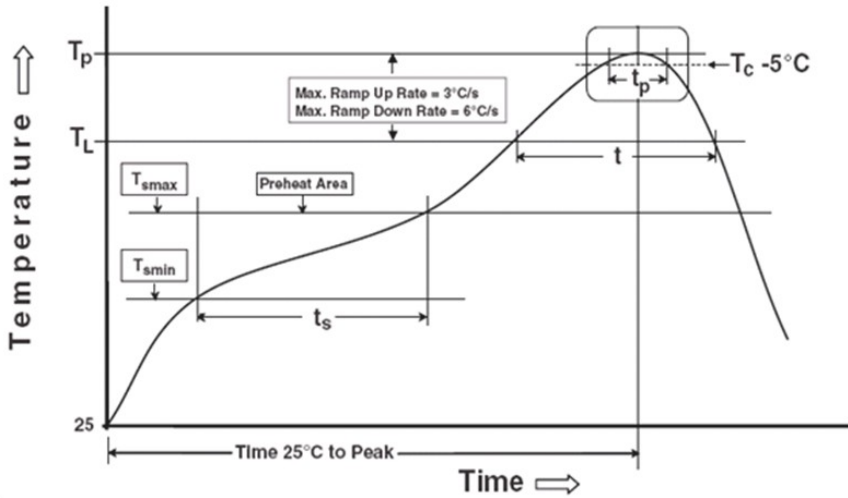

Note:

Reference: IPC/JEDEC J-STD-020D

Preheat

| | |
|--|-----------------|
| Temperature min (T_{smin}) | 150 °C |
| Temperature max (T_{smax}) | 200°C |
| Time (T_{smin} to T_{smax}) (t_s) | 60-120 seconds |
| Average ramp-up rate (T_{smax} to T_p) | 3 °C/second max |

Other

| | |
|--|------------------|
| Liquidus Temperature (T_L) | 217 °C |
| Time above Liquidus Temperature (t_L) | 60-100 sec |
| Peak Temperature (T_p) | 260°C |
| Time within 5 °C of Actual Peak Temperature: $T_p - 5^\circ\text{C}$ | 30 s |
| Ramp- Down Rate from Peak Temperature | 6°C /second max. |
| Time 25°C to peak temperature | 8 minutes max. |
| Reflow times | 3 times |

Precautions for General Storage

- Avoid storage locations where devices may be exposed to moisture or direct sunlight.
- Follow the precautions printed on the packing label of the device for transportation and storage.
- Keep the storage location temperature and humidity within a range of 5°C to 35°C and 20 % to 60 %, respectively.
- Do not store the products in locations with poisonous gases (especially corrosive gases) or in dusty conditions.
- Store the products in locations with minimal temperature fluctuations. Rapid temperature changes during storage can cause condensation, resulting in lead oxidation or corrosion, which will deteriorate the solderability of the leads.
- When restoring devices after removal from their packing, use anti-static containers.
- Do not allow loads to be applied directly to devices while they are in storage.
- If devices have been stored for more than two years under normal storage conditions, it is recommended that you check the leads for ease of soldering prior to use.

EVERLIGHT

DISCLAIMER

1. Above specification may be changed without notice. EVERLIGHT will reserve authority on material change for above specification.
2. The graphs shown in this datasheet are representing typical data only and do not show guaranteed values.
3. When using this product, please observe the absolute maximum ratings and the instructions for use outlined in these specification sheets. EVERLIGHT assumes no responsibility for any damage resulting from use of the product which does not comply with the absolute maximum ratings and the instructions included in these specification sheets.
4. These specification sheets include materials protected under copyright of EVERLIGHT. Reproduction in any form is prohibited without the specific consent of EVERLIGHT.
5. This product is not intended to be used for military, aircraft, automotive, medical, life sustaining or life saving applications or any other application which can result in human injury or death. Please contact authorized Everlight sales agent for special application request.
6. Statements regarding the suitability of products for certain types of applications are based on Everlight's knowledge of typical requirements that are often placed on Everlight products in generic applications. Such statements are not binding statements about the suitability of products for a particular application. It is the customer's responsibility to validate that a particular product with the properties described in the product specification is suitable for use in a particular application. Parameters provided in datasheets and/or specifications may vary in different applications and performance may vary over time. All operating parameters, including typical parameters, must be validated for each customer application by the customer's technical experts. Product specifications do not expand or otherwise modify Everlight's terms and conditions of purchase, including but not limited to the warranty expressed therein