

### 8 PIN SOP HIGH SPEED 1Mbit/s TRANSISTOR PHOTOCOUPLER EL045X EL050X Series

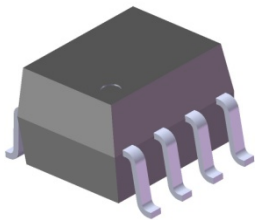

#### Features

- Compliance Halogen Free  
(Br <900 ppm ,Cl <900 ppm , Br+Cl < 1500 ppm)
- High speed 1Mbit/s
- 15kV/μs minimum common mode transient immunity at VCM= 1500V (EL0453)
- High isolation voltage between input and output (Viso=3750 Vrms )
- Guaranteed performance from 0°C to 70°C
- Wide operating temperature range of -55°C to 100°C
- Compliance with EU REACH
- Pb free and RoHS compliant
- UL and cUL approved (No. E214129)
- VDE approved (No. 40028116)
- SEMKO approved
- NEMKO approved
- DEMKO approved
- FIMKO approved Description

#### Schematic

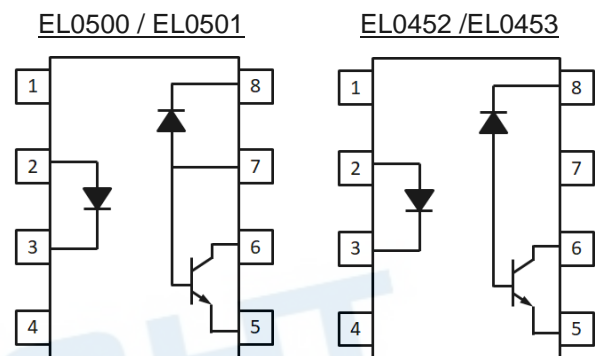

#### Pin Configuration

1. No Connection
2. Anode
3. Cathode
4. No Connection
5. Gnd
6.  $V_{out}$
7.  $V_B$
8.  $V_{CC}$

#### Pin Configuration

1. No Connection
2. Anode
3. Cathode
4. No Connection
5. Gnd
6.  $V_{out}$
7. No Connection
8.  $V_{CC}$

#### Description

The EL0500, EL0501, EL0452 and EL0453 devices each consist of an infrared emitting diode, optically coupled to a high speed photo detector transistor. A separate connection for the photodiode bias and output-transistor collector increase the speed by several orders of magnitude over conventional phototransistor couplers by reducing the base-collector capacitance of the input transistor. The devices are packaged in an 8-pin small outline package which conforms to the standard SO-8 footprint.

#### Applications

- Line receivers
- Telecommunication equipments
- Power transistor isolation in motor drives
- Replacement for low speed phototransistor photo couplers
- Feedback loop in switch-mode power supplies
- Home appliances
- High speed logic ground isolation

**Absolute Maximum Ratings (Ta=25°C)**

| Parameter |   | Symbol                               | Rating     | Unit  |
|-----------|---|--------------------------------------|------------|-------|
| Input     | Forward current                             | I <sub>F</sub>                       | 25         | mA    |
|           | Peak forward current<br>(50% duty, 1ms P.W) | I <sub>FP</sub>                      | 50         | mA    |
|           | Peak transient current<br>(≤1μs P.W,300pps) | I <sub>Ftrans</sub>                  | 1          | A     |
|           | Reverse voltage                             | V <sub>R</sub>                       | 5          | V     |
|           | Power dissipation                           | P <sub>IN</sub>                      | 45         | mW    |
|           | Power dissipation                           | P <sub>O</sub>                       | 100        | mW    |
| Output    | Emitter-Base reverse<br>voltage             | EL0500<br>EL0501<br>V <sub>EBR</sub> | 5          | V     |
|           | Base current                                | EL0500<br>EL0501<br>I <sub>B</sub>   | 5          | mA    |
|           | Average Output current                      | I <sub>O(AVG)</sub>                  | 8          | mA    |
|           | Peak Output current                         | I <sub>O(PK)</sub>                   | 16         | mA    |
|           | Output voltage                              | V <sub>O</sub>                       | -0.5 to 20 | V     |
|           | Supply voltage                              | V <sub>CC</sub>                      | -0.5 to 30 | V     |
|           | Isolation voltage *1                        | V <sub>ISO</sub>                     | 3750       | V rms |
|           | Operating temperature                       | T <sub>OPR</sub>                     | -55 ~ +100 | °C    |
|           | Storage temperature                         | T <sub>STG</sub>                     | -55 ~ +125 | °C    |
|           | Soldering temperature *2                    | T <sub>SOL</sub>                     | 260        | °C    |

**Notes**

\*1 AC for 1 minute, R.H.= 40 ~ 60% R.H. In this test, pins 1, 2, 3, 4 are shorted together, and pins 5, 6, 7, 8 are shorted together.

\*2 For 10 seconds.

**Electrical Characteristics (T<sub>A</sub>=0 to 70°C unless specified otherwise)**

**Input**

| Parameter                                  | Symbol                           | Min. | Typ. | Max. | Unit  | Condition             |
|--|----------------------------------|------|------|------|-------|-----------------------|
| Forward Voltage                            | V <sub>F</sub>                   | -    | 1.45 | 1.8  | V     | I <sub>F</sub> =16mA  |
| Reverse Voltage                            | V <sub>R</sub>                   | 5.0  | -    | -    | V     | I <sub>R</sub> = 10μA |
| Temperature coefficient of forward voltage | ΔV <sub>F</sub> /ΔT <sub>A</sub> | -    | -1.9 | -    | mV/°C | I <sub>F</sub> =16mA  |

**Output**

| Parameter                 | Symbol           | Min | Typ.  | Max. | Unit | Condition   |
|---------------------------|------------------|-----|-------|------|------|---|
| Logic High Output Current | I <sub>OH</sub>  | -   | 0.001 | 0.5  | μA   | I <sub>F</sub> =0mA, V <sub>O</sub> =V <sub>CC</sub> =5.5V, T <sub>A</sub> =25°C      |
|                           |                  | -   | 0.01  | 1    |      | I <sub>F</sub> =0mA, V <sub>O</sub> =V <sub>CC</sub> =15V, T <sub>A</sub> =25°C       |
|                           |                  | -   | -     | 50   |      | I <sub>F</sub> =0mA, V <sub>O</sub> =V <sub>CC</sub> =15V                             |
| Logic Low Supply Current  | I <sub>CCL</sub> | -   | 140   | 200  | μA   | I <sub>F</sub> =16mA, V <sub>O</sub> =Open, V <sub>CC</sub> =15V                      |
| Logic High Supply Current | I <sub>CCH</sub> | -   | 0.01  | 1    | μA   | I <sub>F</sub> =0mA, V <sub>O</sub> =Open, V <sub>CC</sub> =15V, T <sub>A</sub> =25°C |
|                           |                  | -   | -     | 2    |      | I <sub>F</sub> =0mA, V <sub>O</sub> =Open, V <sub>CC</sub> =15V                       |

**Transfer Characteristics (T<sub>A</sub>=0 to 70°C unless specified otherwise)**

| Parameter                | Symbol          | Min    | Typ. | Max.   | Unit | Condition |  |
|--------------------------|-----------------|--------|------|--|------|-----------|--|
| Current Transfer Ratio   | CTR             | EL0500 | 7    | -  | 50   | %         | I <sub>F</sub> = 16mA, V <sub>O</sub> = 0.4V, V <sub>CC</sub> =4.5V, T <sub>A</sub> =25°C  |
|                          |                 | EL0501 | 19   | -  | 50   |           |  |
|                          |                 | EL0452 |      |  |      |           |  |
|                          |                 | EL0453 | 5    | -  | -    |           | I <sub>F</sub> = 16mA, V <sub>O</sub> = 0.5V, V <sub>CC</sub> =4.5V                        |
|                          |                 | EL0500 | 15   | -  | -    |           |  |
|                          |                 | EL0501 |      |  |      |           |  |
| Logic Low Output Voltage | V <sub>OL</sub> | EL0500 | -    | 0.18   | 0.4  | V         | I <sub>F</sub> = 16mA, I <sub>O</sub> = 1.1mA, V <sub>CC</sub> =4.5V, T <sub>A</sub> =25°C |
|                          |                 | EL0501 | -    | 0.18   | 0.4  |           | I <sub>F</sub> = 16mA, I <sub>O</sub> = 3mA, V <sub>CC</sub> =4.5V, T <sub>A</sub> =25°C   |
|                          |                 | EL0452 |      |  |      |           |  |
|                          |                 | EL0453 | -    | -  | 0.5  |           | I <sub>F</sub> = 16mA, I <sub>O</sub> = 0.8mA, V <sub>CC</sub> =4.5V                       |
|                          |                 | EL0500 |      |  |      |           |  |
|                          |                 | EL0501 |      |  |      |           |  |
| EL0452                   | -               | -      | 0.5  | I <sub>F</sub> = 16mA, I <sub>O</sub> = 2.4mA, V <sub>CC</sub> =4.5V |      |           |  |
| EL0453                   |                 |        |      |  |      |           |  |

Switching Characteristics ( $T_A=0$  to  $70^\circ\text{C}$  unless specified otherwise,  $I_F=16\text{mA}$ ,  $V_{CC}=5\text{V}$ )

| Parameter  | Symbol                     | Min   | Typ.  | Max. | Unit                   | Condition   |
|--|----------------------------|-------|-------|------|------------------------|---|
| Propagation Delay Time to Logic Low (Fig.8)                        | EL0500                     | -     | -     | 1.5  | $\mu\text{s}$          | $R_L=4.1\text{K}\Omega$ , $T_A=25^\circ\text{C}$  |
|  |                            | -     | -     | 2.0  |                        | $R_L=4.1\text{K}\Omega$   |
|  | EL0501<br>EL0452<br>EL0453 | -     | -     | 0.8  |                        | $R_L=1.9\text{K}\Omega$ , $T_A=25^\circ\text{C}$  |
|  |                            | -     | -     | 1.0  |                        | $R_L=1.9\text{K}\Omega$   |
| Propagation Delay Time to Logic High (Fig.8)                       | EL0500                     | -     | -     | 1.5  | $\mu\text{s}$          | $R_L=4.1\text{K}\Omega$ , $T_A=25^\circ\text{C}$  |
|  |                            | -     | -     | 2.0  |                        | $R_L=4.1\text{K}\Omega$   |
|  | EL0501<br>EL0452<br>EL0453 | -     | -     | 0.8  |                        | $R_L=1.9\text{K}\Omega$ , $T_A=25^\circ\text{C}$  |
|  |                            | -     | -     | 1.0  |                        | $R_L=1.9\text{K}\Omega$   |
| Common Mode Transient Immunity at Logic High (Fig.9) <sup>*3</sup> | EL0500                     | -     | 1,000 | -    | $\text{V}/\mu\text{s}$ | $I_F = 0\text{mA}$ , $V_{CM}=10\text{Vp-p}$ ,<br>$R_L=4.1\text{K}\Omega$ , $T_A =25^\circ\text{C}$      |
|  | EL0452<br>EL0501           | -     | 1,000 | -    |                        | $I_F = 0\text{mA}$ , $V_{CM}=10\text{Vp-p}$ ,<br>$R_L=1.9\text{K}\Omega$ , $T_A =25^\circ\text{C}$      |
|  | EL0453                     | 15000 | -     | -    |                        | $I_F = 0\text{mA}$ ,<br>$V_{CM}=1500\text{Vp-p}$ ,<br>$R_L=1.9\text{K}\Omega$ , $T_A =25^\circ\text{C}$ |
| Common Mode Transient Immunity at Logic Low (Fig.9) <sup>*3</sup>  | EL0500                     | -     | 1,000 | -    | $\text{V}/\mu\text{s}$ | $I_F = 16\text{mA}$ , $V_{CM}=10\text{Vp-p}$ ,<br>$R_L=4.1\text{K}\Omega$ , $T_A =25^\circ\text{C}$     |
|  | EL0452<br>EL0501           | -     | 1,000 | -    |                        | $I_F = 16\text{mA}$ , $V_{CM}=10\text{Vp-p}$ ,<br>$R_L=1.9\text{K}\Omega$ , $T_A=25^\circ\text{C}$      |
|  | EL0453                     | 15000 | -     | -    |                        | $I_F = 16\text{mA}$ ,<br>$V_{CM}=1500\text{Vp-p}$ ,<br>$R_L=1.9\text{K}\Omega$ , $T_A=25^\circ\text{C}$ |

\* Typical values at  $T_a = 25^\circ\text{C}$

Typical Electro-Optical Characteristics Curves

Figure 5. Logic High Output Current vs Ambient Temperature

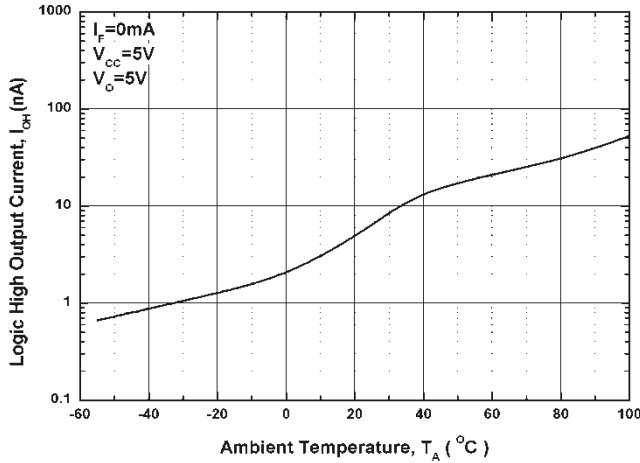

Figure 1. Forward Current vs Forward Voltage

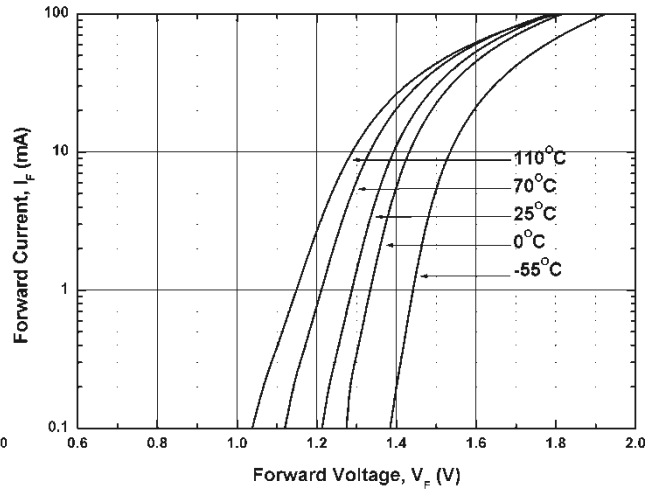

Figure 2. Current Transfer Ratio vs Forward Current

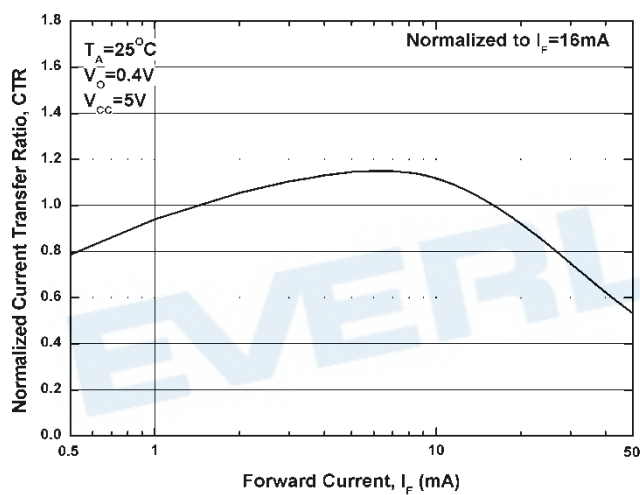

Figure 3. Current Transfer Ratio vs Ambient Temperature

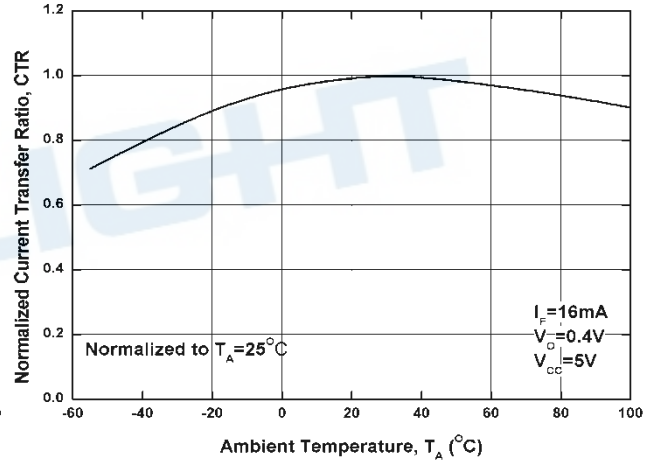

Figure 4. Output Current vs Output Voltage

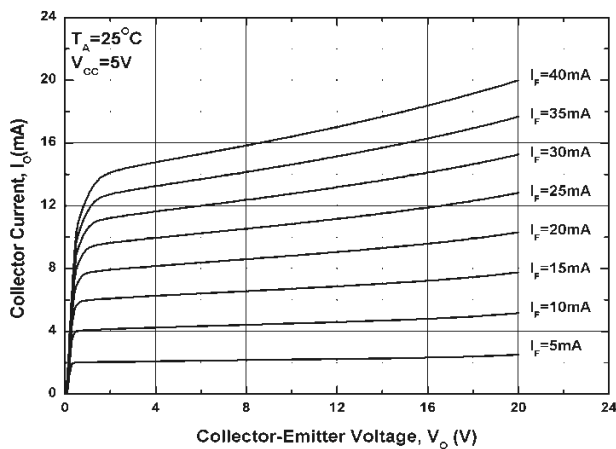

Figure 6. Propagation Delay vs. Load Resistance

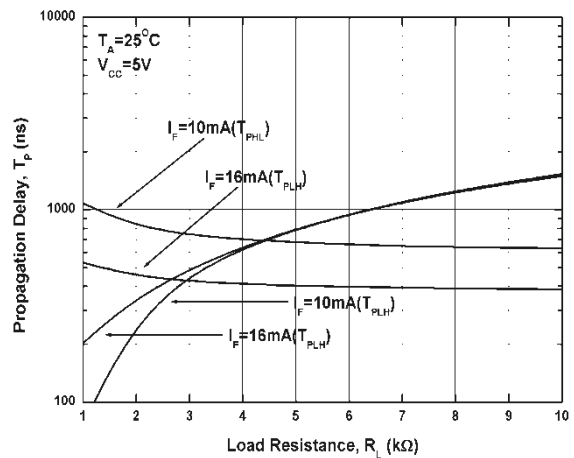

Figure 7. Propagation Delay vs. Temperature

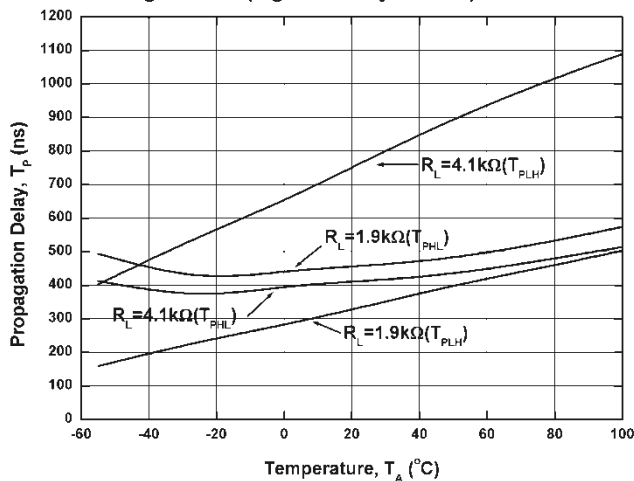

Figure 8 Switching Time Test Circuit & Waveform

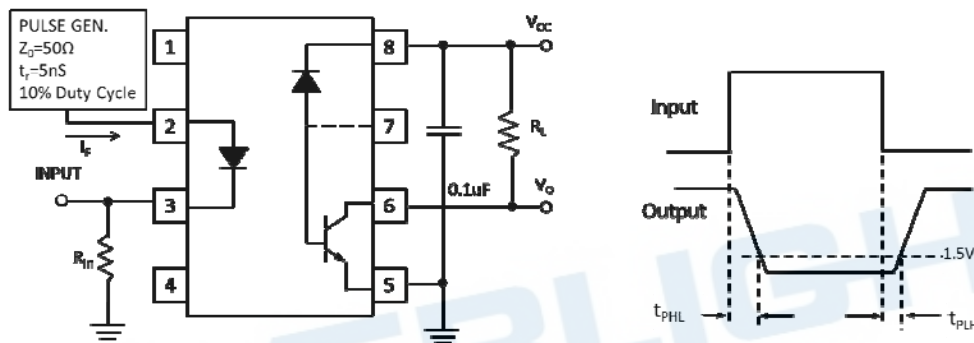
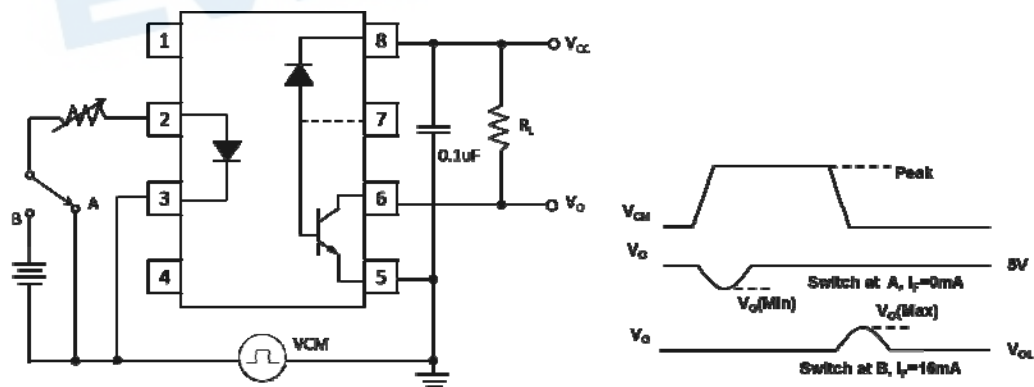

Figure 9 Transient Immunity Test Circuit & Waveform



**Note:**

\*3 Common mode transient immunity in logic high level is the maximum tolerable (positive)  $dV_{cm}/dt$  on the leading edge of the common mode pulse signal VCM, to assure that the output will remain in a logic high state (i.e.,  $V_o > 2.0V$ ).

Common mode transient immunity in logic low level is the maximum tolerable (negative)  $dV_{cm}/dt$  on the trailing edge of the common mode pulse signal, VCM, to assure that the output will remain in a logic low state (i.e.,  $V_o < 0.8V$ ).

**Order Information**

**Part Number**

**EL050X(Z)-V**

Or

**EL045X(Z)-V**

**Note**

- X = Part No. (X = 0 or 1) for EL050X ; (X=2 or 3) for EL045X
- Z = Tape and reel option (TA, TB).
- V = VDE (optional)

| Option | Description                 | Packing quantity    |
|--------|-----------------------------|---------------------|
| (TA)   | TA tape & reel option       | 2000 units per reel |
| (TB)   | TB tape & reel option       | 2000 units per reel |
| (TA)-V | TA tape & reel option + VDE | 2000 units per reel |
| (TB)-V | TB tape & reel option + VDE | 2000 units per reel |

**Package Drawing  
 (Dimensions in mm)**

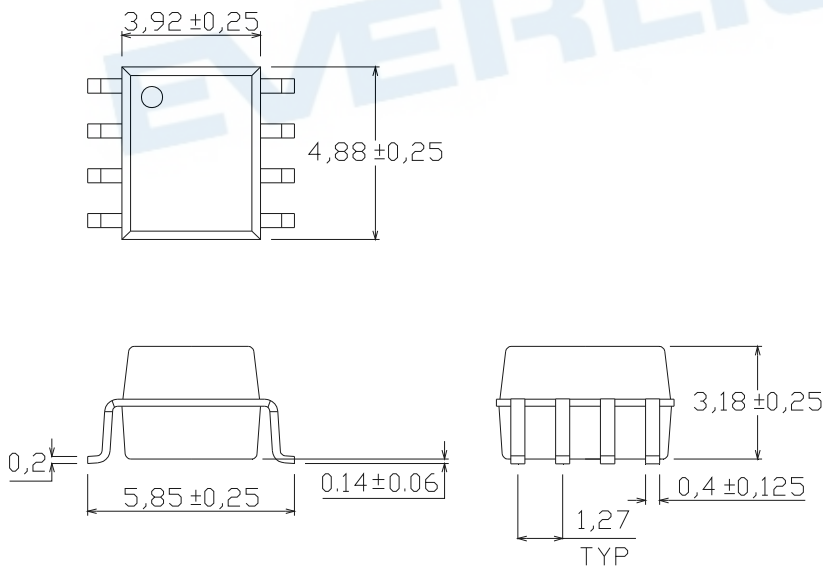

**Recommended pad layout for surface mount leadform**

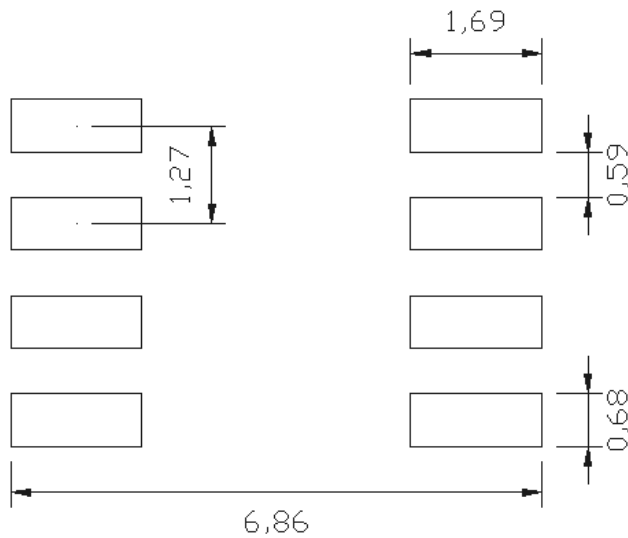

**Notes**

Suggested pad dimension is just for reference only.  
 Please modify the pad dimension based on individual need.

**Device Marking**

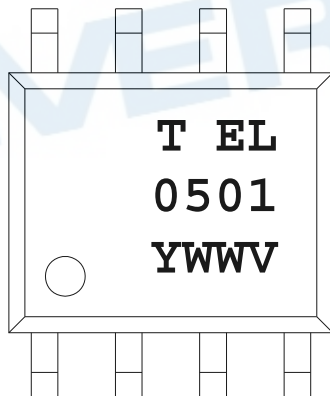

**Notes**

- T denotes Factory  
 No code : made in China  
 T : made in Taiwan
- EL denotes EVERLIGHT
- 0501 denotes Device Number
- Y denotes 1 digit Year code
- WW denotes 2 digit Week code
- V denotes VDE (optional)

**Tape & Reel Packing Specifications**

**Option TA**

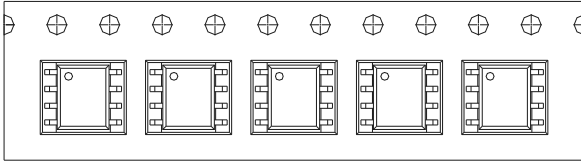

**Option TB**

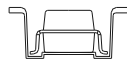
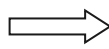
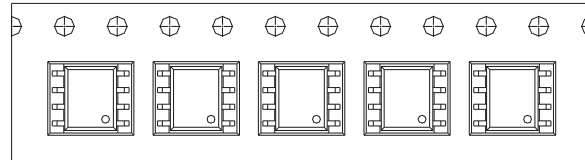

Direction of feed from reel

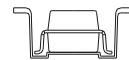
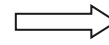

Direction of feed from reel

**Tape dimensions**

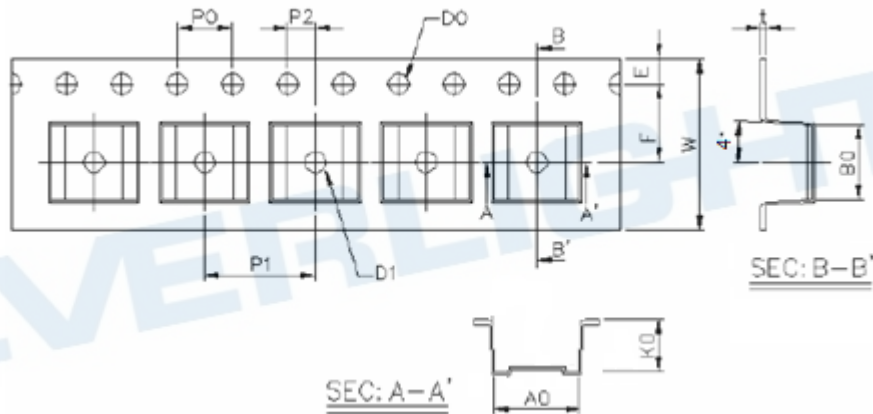

|               |           |           |           |           |                   |           |
|---------------|-----------|-----------|-----------|-----------|-------------------|-----------|
| Dimension No. | <b>A0</b> | <b>B0</b> | <b>D0</b> | <b>D1</b> | <b>E</b>          | <b>F</b>  |
| Dimension(mm) | 6.2±0.1   | 5.26±0.1  | 1.5±0.1   | 1.5±0.3   | 1.75±0.1          | 5.5±0.1   |
| Dimension No. | <b>Po</b> | <b>P1</b> | <b>P2</b> | <b>t</b>  | <b>W</b>          | <b>K0</b> |
| Dimension(mm) | 4.0±0.1   | 8.0±0.1   | 2.0±0.1   | 0.25±0.1  | 12.0+0.3/<br>-0.1 | 3.75±0.1  |

## Precautions for Use

### 1. Soldering Condition

#### 1.1 (A) Maximum Body Case Temperature Profile for evaluation of Reflow Profile

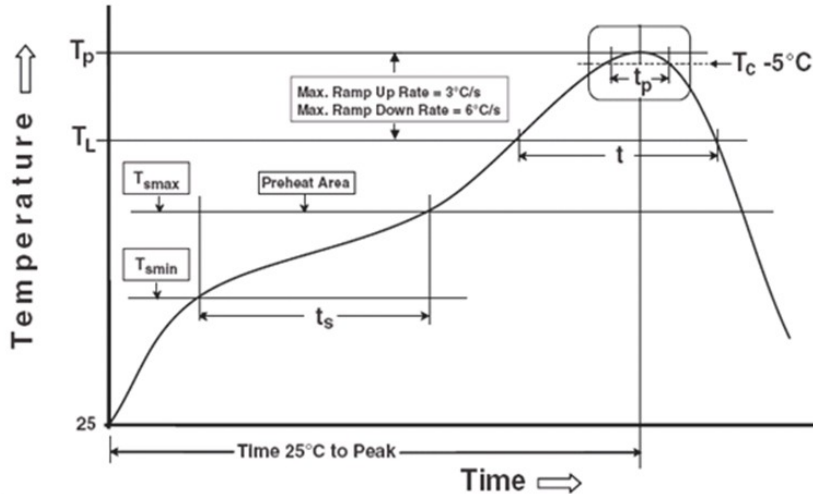

Note:

Reference: IPC/JEDEC J-STD-020D

#### Preheat

|  |                 |
|--|-----------------|
| Temperature min ( $T_{smin}$ )               | 150 °C          |
| Temperature max ( $T_{smax}$ )               | 200°C           |
| Time ( $T_{smin}$ to $T_{smax}$ ) ( $t_s$ )  | 60-120 seconds  |
| Average ramp-up rate ( $T_{smax}$ to $T_p$ ) | 3 °C/second max |

#### Other

|  |                  |
|--|------------------|
| Liquidus Temperature ( $T_L$ )                                       | 217 °C           |
| Time above Liquidus Temperature ( $t_L$ )                            | 60-100 sec       |
| Peak Temperature ( $T_p$ )   | 260°C            |
| Time within 5 °C of Actual Peak Temperature: $T_p - 5^\circ\text{C}$ | 30 s             |
| Ramp- Down Rate from Peak Temperature                                | 6°C /second max. |
| Time 25°C to peak temperature  | 8 minutes max.   |
| Reflow times   | 3 times          |

## DISCLAIMER

1. Above specification may be changed without notice. EVERLIGHT will reserve authority on material change for above specification.
2. The graphs shown in this datasheet are representing typical data only and do not show guaranteed values.
3. When using this product, please observe the absolute maximum ratings and the instructions for use outlined in these specification sheets. EVERLIGHT assumes no responsibility for any damage resulting from use of the product which does not comply with the absolute maximum ratings and the instructions included in these specification sheets.
4. These specification sheets include materials protected under copyright of EVERLIGHT. Reproduction in any form is prohibited without the specific consent of EVERLIGHT.
5. This product is not intended to be used for military, aircraft, automotive, medical, life sustaining or life saving applications or any other application which can result in human injury or death. Please contact authorized Everlight sales agent for special application request.
6. Statements regarding the suitability of products for certain types of applications are based on Everlight's knowledge of typical requirements that are often placed on Everlight products in generic applications. Such statements are not binding statements about the suitability of products for a particular application. It is the customer's responsibility to validate that a particular product with the properties described in the product specification is suitable for use in a particular application. Parameters provided in datasheets and/or specifications may vary in different applications and performance may vary over time. All operating parameters, including typical parameters, must be validated for each customer application by the customer's technical experts. Product specifications do not expand or otherwise modify Everlight's terms and conditions of purchase, including but not limited to the warranty expressed therein.