

Ambient Light Sensor – DIP 5mm T-1 3/4 EAALST05RDMA0



Features

- Close responsively to the human eye spectrum
- Light to Current, analog output
- Good output linearity across wide illumination range
- Low sensitivity variation across various light sources
- Guaranteed temperature performance, -40°C to 85°C
- Wide supply voltage range, 2.5V to 5.5V
- Size : 5mm Lamp (Flat lens)
- RoHS compliant and Pb Free package
- Compliance with EU REACH.

Description

The EAALST05RDMA0 is a low cost ambient light sensor, consisting of phototransistor in miniature SMD. Everlight Americas ALS series product are a good effective solution to the power saving of display backlighting of mobile appliances, such as the mobile phones, NB and PDAs. Due to the high rejection ratio of infrared radiation, the spectral response of the ambient light sensor is close to human eyes.

Applications

- Detection of ambient light to control display backlighting
- Mobile devices – mobile phones, PDAs
- Computing device – TFT LCD monitor for Notebook computer
- Consumer device – TFT LCD TV, plasma TV, video camera, digital camera, toys
- Automatic residential and commercial management
- Automatic contrast enhancement for electronic signboard
- Ambient light monitoring device for daylight and artificial light
 - Street light, CCD/CCTV

Package Dimensions

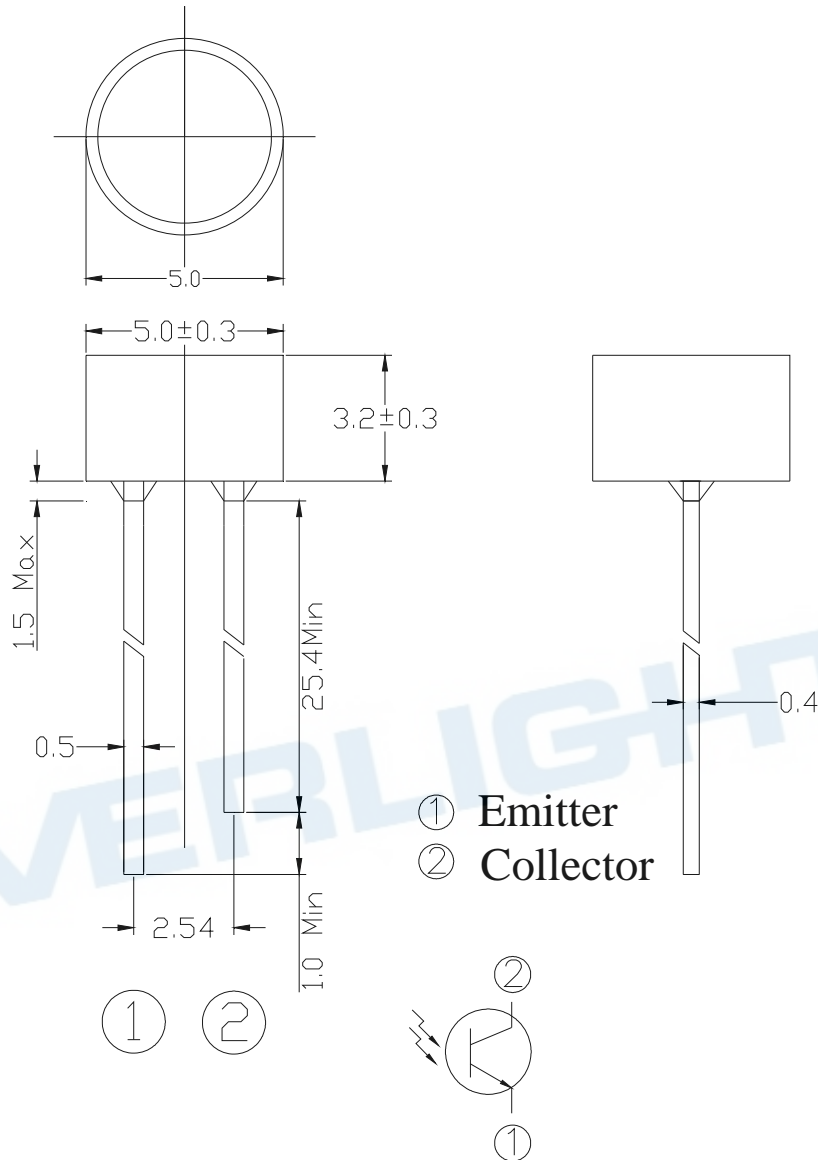

Notes:

1. All dimensions are in millimeters
2. Tolerances unless dimensions ± 0.1 mm

Absolute Maximum Ratings

Parameter	Symbol	Rating	Unit
Supply Voltage	V_{CC}	-0.5~6.0	V
Operating Temperature Range	T_{opr}	-40~+85	°C
Storage Temperature Range	T_{stq}	-40~+100	°C
Soldering Temperature Range	T_{sol}	260	°C

Recommended Operating Conditions

Parameter	Symbol	Min.	Max.	Unit
Operating Temperature	T_{opr}	-40	+85	°C
Supply Voltage	V_{CC}	2.5	5.5	V

Rankings

Bin Code	Symbol	Min.	Max.	Unit	Test Condition
1	$I_{C(ON)}$	5	12	uA	$V_{CE}=5V$ $E_V=100Lux$
2		12	17		
3		17	23		

Electro-Optical Characteristics (Ta=25°C)

Parameter	Symbol	Min.	Typ.	Max.	Unit	Condition
Dark Current	I_{CEO}	---	---	0.1	uA	$V_{CE}=10V$ $E_V=0Lux$
Collector-Emitter Saturation Voltage	$V_{CE(sat)}$	---	---	0.4	V	$I_C=2mA$ $E_V=1000Lux$
Light Current	I_{PH1}	7	10	---	uA	$V_{CE}=5V$ $E_V=100Lux$ [Note1]
	I_{PH2}	70	100	---		$V_{CE}=5V$ $E_V=1000Lux$ [Note1]
	I_{PH3}	---	480	---		$V_{CE}=5V$ $E_V=1000Lux$ [Note2]
Photocurrent Ratio	I_{PH3} / I_{PH2}	---	4.8	---	---	$V_{CE}=5V$ $E_V=1000Lux$
Saturation Output Voltage	V_O	4.5	4.6	---	V	$V_{CE}=5V$ $E_V=1000Lux$ $R_L=75K\Omega$ [Note2]
Peak Sensitivity Wavelength	λ_p	---	630	---	nm	---
Sensitivity Wavelength Range	λ	390	---	700	nm	---
Rise Time	t_r	---	0.11	---	ms	$V_{CE}=5V$
Fall Time	t_f	---	0.22	---	ms	$R_L = 7.5K\Omega$
Angle of half Sensitivity	$2\theta_{1/2}$	---	143	---	Deg	$I_F = 20 mA$

Note:

1. White Fluorescent light (Color Temperature = 6500K) is used as light source. However, White LED is substituted in mass production.
2. Illuminance by CIE standard illuminant-A / 2856K, incandescent lamp.

Typical Electro-Optical Characteristics Curves

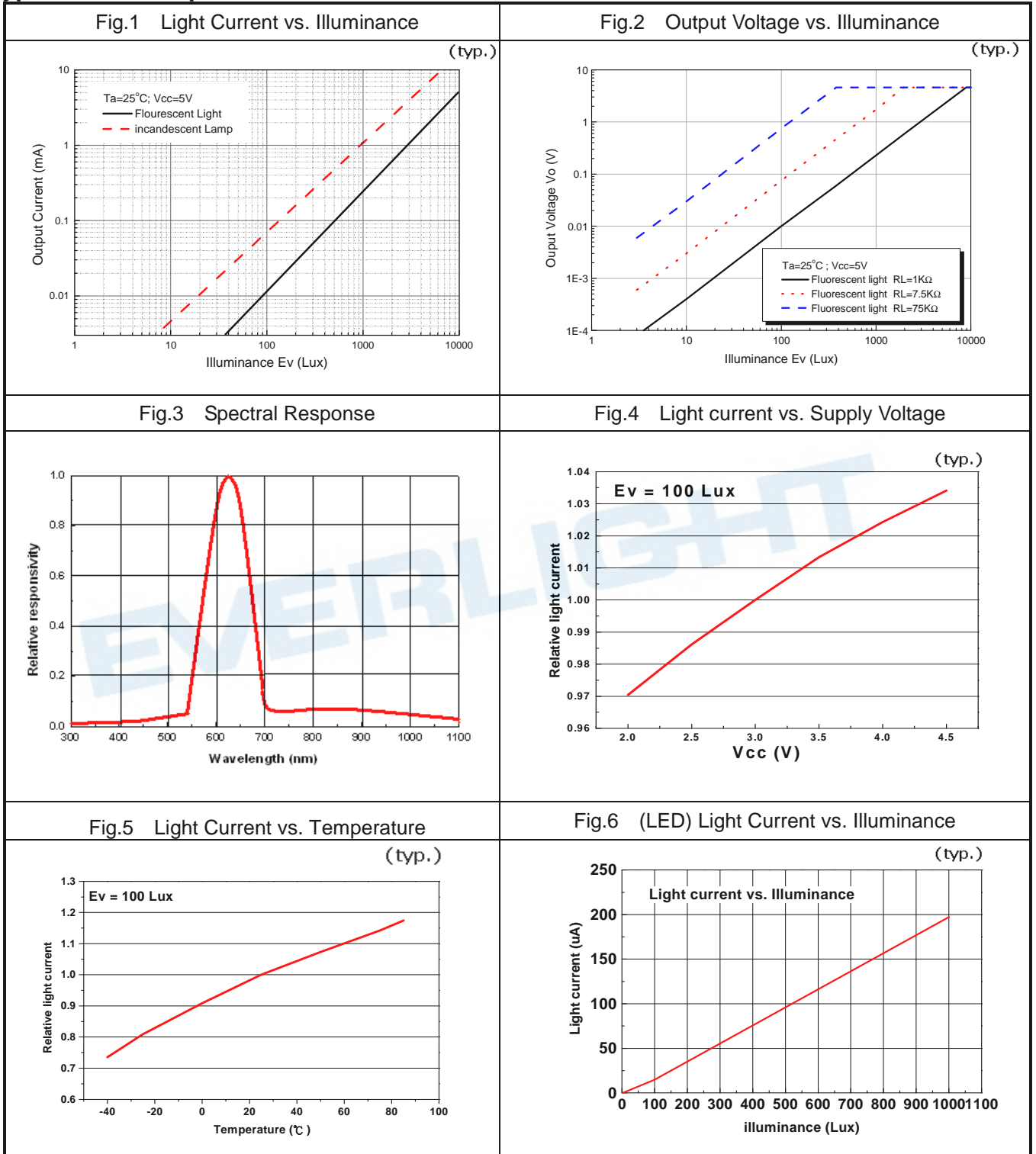

Converting Photocurrent to Voltage

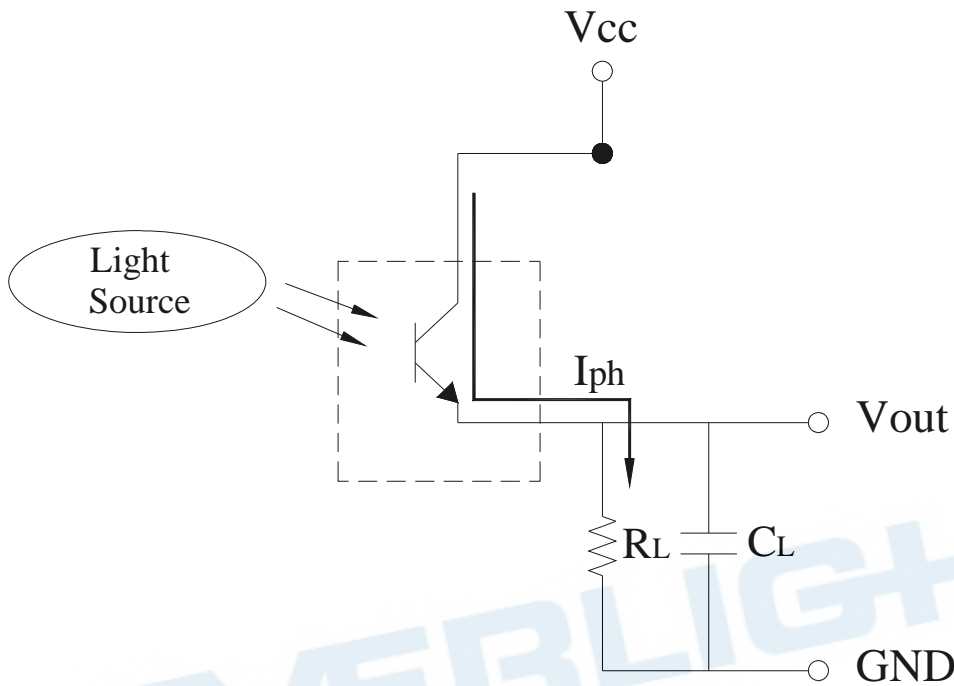

Note :

1. The output voltage (V_{out}) is the product of photocurrent (I_{PH}) and loading resistor (R_L)
2. A right loading resistor shall be chosen to meet the requirement of maximum ambient light, and output saturation voltage:

$$V_{out(max.)} = I_{out(max.)} \times R_L \leq V_{out(saturation)} = V_{cc} - 0.4V$$

Packing Quantity Specification

1.500PCS/1Bag · 5Bags/1Box

2.10Boxes/1Carton

Label Format

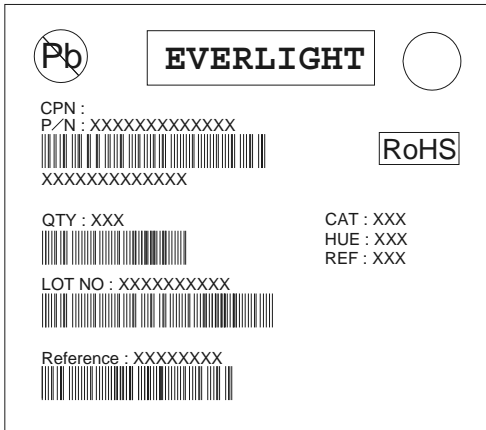

- CPN : Customer's Product Number
- P/N : Product Number
- QTY : Packing Quantity
- CAT : Ranks
- HUE : Peak Wavelength
- REF : Reference
- LOT No : Lot Number

EVERLIGHT

DISCLAIMER

1. EVERLIGHT reserves the right(s) on the adjustment of product material mix for the specification.
2. The product meets EVERLIGHT published specification for a period of twelve (12) months from date of shipment.
3. The graphs shown in this datasheet are representing typical data only and do not show guaranteed values.
4. When using this product, please observe the absolute maximum ratings and the instructions for using outlined in these specification sheets. EVERLIGHT assumes no responsibility for any damage resulting from the use of the product which does not comply with the absolute maximum ratings and the instructions included in these specification sheets.
5. These specification sheets include materials protected under copyright of EVERLIGHT. Reproduction in any form is prohibited without obtaining EVERLIGHT's prior consent.
6. This product is not intended to be used for military, aircraft, automotive, medical, life sustaining or life saving applications or any other application which can result in human injury or death. Please contact authorized Everlight sales agent for special application request.

EVERLIGHT