

Ambient Light Sensor

5mm T-1 3/4

ALS-PDIC243-3B

Features

- Excellent IR-Cut performance
- Close responsively to the human eye spectrum
- Light to Current, analog output
- Good output linearity across wide illumination range
- Low sensitivity variation across various light sources
- Operation temperature performance, -40°C to 85°C
- Wide supply voltage range, 1.8V to 5.5V
- Size: 5mm Lamp (Flat lens)
- The product itself will remain within RoHS compliant version
- Compliance with EU REACH
- Compliance Halogen Free(Br < 900ppm, Cl < 900ppm, Br+Cl < 1500ppm)



Description

The ALS-PDIC243-3B is an ambient light sensor, which incorporates a photodiode and a current amplifier IC in DIP package. EVERLIGHT ALS series products are a good effective solution to the power saving of display backlighting of mobile appliances, such as the mobile phones, NB and PDAs. Due to the high rejection ratio of infrared radiation, the spectral response of the ambient light sensor is close to human eyes. Also, it is very suitable to use ALS product for opto-switch application.

Applications

- Ambient light monitoring device for daylight and artificial light
 - CCD camera/CCTV security equipment, Street light
- Detection of ambient light to control display backlighting
 - Computing device – TFT LCD monitor for Notebook computer
 - Consumer device – TFT LCD TV, video camera, digital camera, toys

Package Dimensions

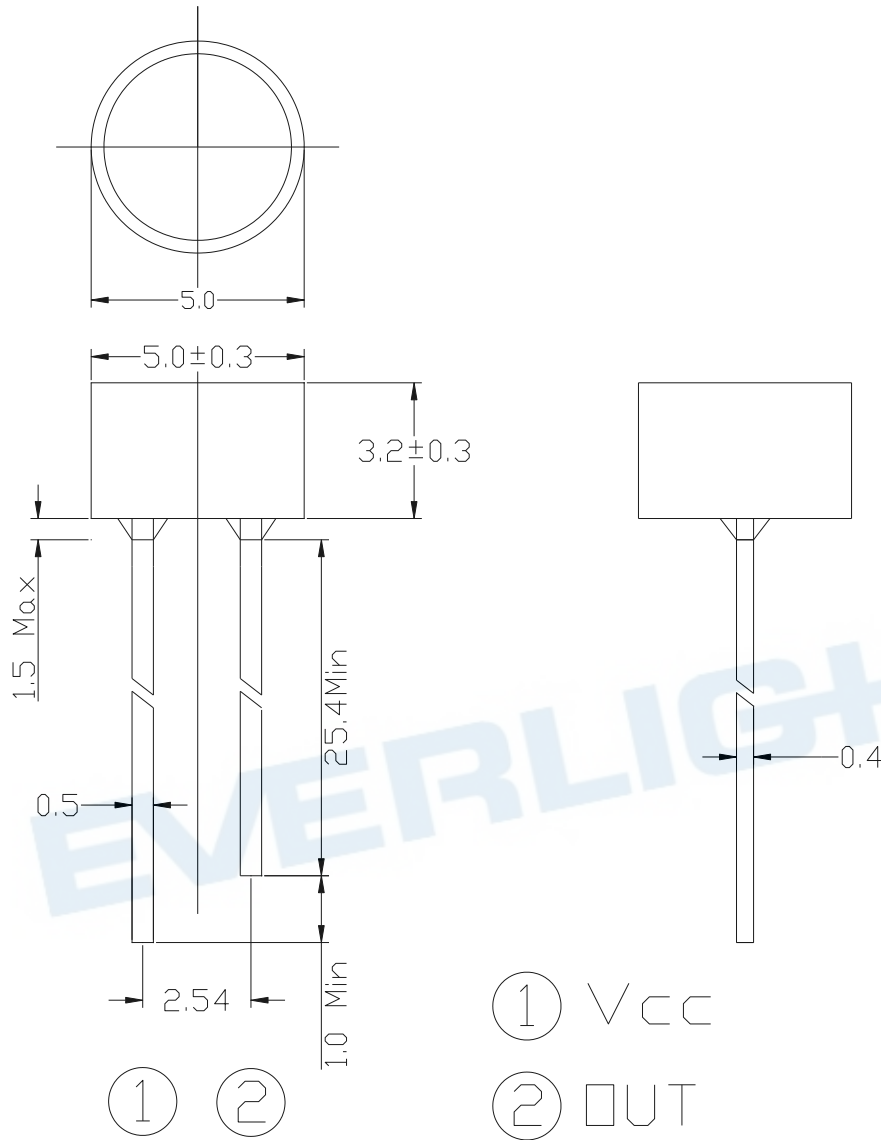

Notes:

1. All dimensions are in millimeters
2. Tolerances unless dimensions ± 0.1 mm

Absolute Maximum Ratings

Parameter	Symbol	Rating	Unit
Supply Voltage	V _{CC}	-0.7 ~ 6.5	V
Operating Temperature Range	T _a	-40 ~ +85	°C
Storage Temperature Range	T _s	-40 ~ +100	°C
Soldering Temperature	T _{sol}	260	°C

Recommended Operating Conditions

Parameter	Symbol	Min.	Max.	Unit
Operating Temperature	T _a	-40	+85	°C
Supply Voltage	V _{CC}	1.8	5.5	V

Rankings

Bin	Symbol	Min.	Max.	Unit	Test Condition
1	I _{PH2}	10	16	uA	V _{CC} =3V E _v = 100Lux
2		14	23		
3		20	30		
4		26	35		

Electrical and Optical Characteristics ($T_a=25^{\circ}\text{C}$)

Parameter	Symbol	MIN	TYP	MAX.	Unit	Test Condition
Dark Current	I_D	---	0.05	0.1	μA	$V_{CC}=3\text{V}$, $E_v=0\text{Lux}$
Light Current	I_{PH1}	1	---	3.5	μA	$V_{CC}=3\text{V}$, $E_v=10\text{Lux}$ [Note1]
	I_{PH2}	10	---	35	μA	$V_{CC}=3\text{V}$, $E_v=100\text{Lux}$ [Note1]
	I_{PH3}	100	---	350	μA	$V_{CC}=3\text{V}$, $E_v=1000\text{Lux}$ [Note1]
	I_{PH4}	100	300	---	μA	$V_{CC}=3\text{V}$, $E_v=1000\text{Lux}$ [Note2]
Photocurrent Ratio	I_{PH4} / I_{PH3}	---	1.2	---	---	$V_{CC}=3\text{V}$, $E_v=1000\text{Lux}$
Saturation Output Voltage	V_{O_RL}	---	1.9	---	V	$V_{CC}=3\text{V}$; $E_v=1000\text{Lux}$, $R_L=100\text{K}\Omega$
Peak Sensitivity Wavelength	λ_p	---	560	---	nm	---
Sensitivity Wavelength Range	λ	390	---	700	nm	---
Rise time	t_r	---	0.36	---	ms	$V_{CC} = 3\text{V}$ $R_L = 27\text{K}\Omega$
Fall time	t_f	---	1.13	---	ms	
Angle of half Sensitivity	$2\theta_{1/2}$	---	143	---	Deg.	$I_F=20\text{mA}$

Note:

1. White Fluorescent light (Color Temperature = 6500K) is used as light source. However, White LED is substituted in mass production.
2. Illuminance by CIE standard illuminant-A / 2856K, incandescent lamp.

Typical Electrical and Optical Characteristics Curves

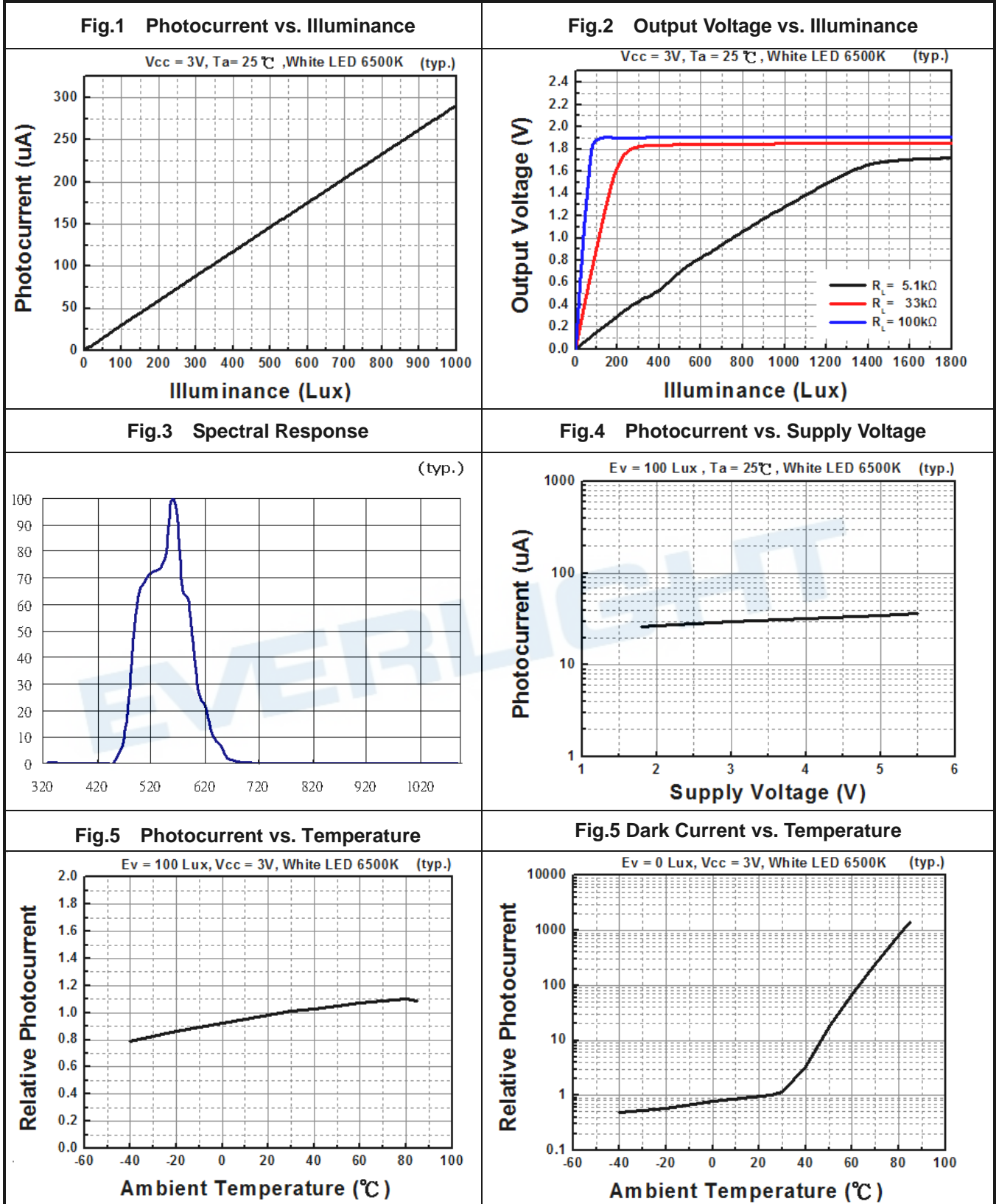

Converting Photocurrent to Voltage

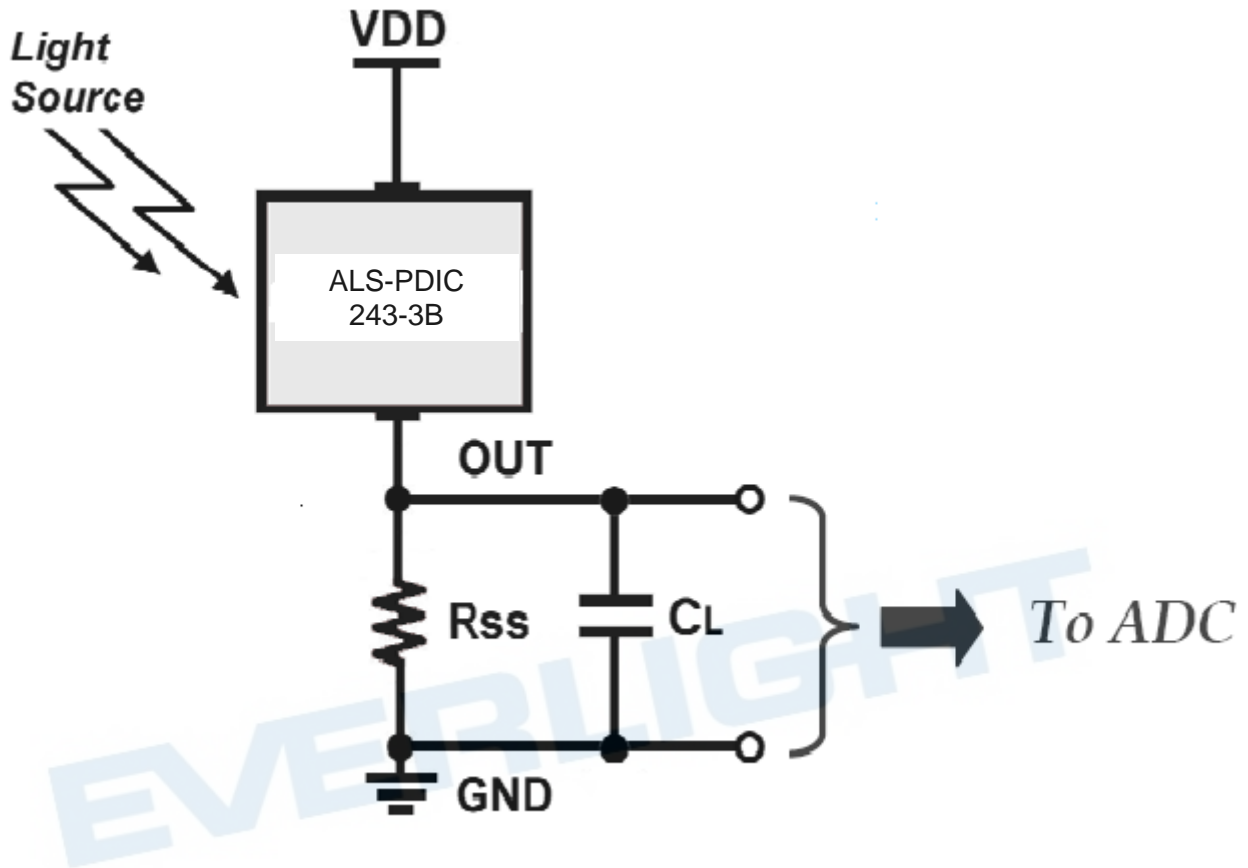

Note:

1. The output voltage (V_{OUT}) is the product of photocurrent (I_{PH}) and loading resistor (R_L)
2. A right loading resistor shall be chosen to meet the requirement of maximum ambient light, and output saturation voltage:

$$V_{OUT_amb_max} = I_{OUT_amb_max}^{(*)} \times R_L \leq V_{OUT} \text{ (saturation)}$$

(*) For $I_{OUT_amb_max}$, please refer to Fig.1.

Packing Quantity Specification

1.500PCS/1Bag , 5Bags/1Box
2.10Boxes/1Carton

Label Format



CPN : XXXXXXXXXXXXXXXXXXXX
XXXXXXXXXX-XXXXXXXXXX-XXXXXXXXXX-XXXXXXXXXX-XXXXXX
P/N : XXXXXXXXXXXX
XXXXXXXXXX-XXXXXXXXXX-XXXXXXXXXX-XXXXXXXXXX-XXXXXX
LOT NO: Y150716XXX-XXXXXXXXXX-XXXXXXXXXX
QTY: 0123456789 HUE: XXXXXXXXXXXX
CAT: XXXXXXXXXXXX REF: XXXXXXXXXXXX
REFERENCE: BTPYMMDDXXXXXX
MADE IN TAIWAN



CPN: Customer's Production Number
P/N : Production Number
QTY: Packing Quantity
CAT: Ranks
HUE: Peak Wavelength
REF: Reference
LOT No: Lot Number
MADE IN TAIWAN: Production Place



DISCLAIMER

1. EVERLIGHT reserves the right(s) on the adjustment of product material mix for the specification.
2. The product meets EVERLIGHT published specification for a period of twelve (12) months from date of shipment.
3. The graphs shown in this datasheet are representing typical data only and do not show guaranteed values.
4. When using this product, please observe the absolute maximum ratings and the instructions for using outlined in these specification sheets. EVERLIGHT assumes no responsibility for any damage resulting from the use of the product which does not comply with the absolute maximum ratings and the instructions included in these specification sheets.
5. These specification sheets include materials protected under copyright of EVERLIGHT. Reproduction in any form is prohibited without obtaining EVERLIGHT's prior consent.
6. This product is not intended to be used for military, aircraft, automotive, medical, life sustaining or life saving applications or any other application which can result in human injury or death. Please contact authorized Everlight sales agent for special application request.

EVERLIGHT