

### EL Power TOP VIEW LED 67-41-SR0501H-AM



#### Features

- Package : PLCC 4 package
- Color : Super Red
- Typ. Luminance Intensity : 1800 mcd @ 50mA
- Viewing angle : 120°
- ESD : 2KV
- MSL : 2
- Qualified AEC-Q102 Class : B1
- The product itself will remain within RoHS compliant version
- Compliance with EU REACH
- Compliance Halogen Free (Br<900ppm, Cl<900ppm, Br+Cl<1500ppm)

#### Applications

- Automotive interior lighting.

## Contents

1. Characteristics .....	3
2. Absolute Maximum Ratings .....	4
3. Characteristics Graph.....	5
4. Binning Information .....	10
5. Part Number.....	13
6. Ordering Information .....	14
7. Mechanical Dimension.....	15
8. Recommended Soldering Pad.....	16
9. Reflow Soldering Profile.....	16
10. Packaging Information.....	17
11. Precaution for Use .....	19
12. Sulfur Test Criteria.....	20

EVERLIGHT

# 1. Characteristics

Parameter	Symbol	Min.	Typ.	Max.	Unit	Condition	
Forward Current	$I_F$	5	50	70	mA	---	
Luminous Intensity	$I_V$	1120	1800	2240	mcd	$I_F=50\text{mA}$	
Forward Voltage	$V_F$	1.75	2.20	3	V	$I_F=50\text{mA}$	
Viewing Angle	$\varphi$	---	120	---	deg	$I_F=50\text{mA}$	
Dominant Wavelength	$\lambda_d$	627	630	639	nm	$I_F=50\text{mA}$	
Thermal Resistance (Junction to Solder)	Real	$R_{th JS real}$	---	---	130	K/W	$I_F=50\text{mA}$
	Electrical	$R_{th JS el}$	---	---	100		

## Notes:

1. Luminous Flux measurement tolerance:  $\pm 8\%$ .
2. The data of Luminous Flux measured at thermal pad= $25^\circ\text{C}$
3. Forward voltage measurement tolerance:  $\pm 0.05\text{V}$
4. The  $V_F$  range shown in the table above indicates 99% output.
5. Tolerance of Dominant Wavelength :  $\pm 1\text{nm}$ .

## 2. Absolute Maximum Ratings

Parameter	Symbol	Ratings	Unit
Power Dissipation	$P_d$	175	mW
Forward Current	$I_F$	70	mA
Surge Current ( $t \leq 10 \mu\text{s}$ ; $D=0.005$ ; $T_s=25^\circ\text{C}$ )	$I_{FM}$	100	mA
Reverse Voltage	$V_R$	Not designed for reverse operation	V
Junction Temperature	$T_J$	125	$^\circ\text{C}$
Operating Temperature	$T_{opr}$	-40 ~ +110	$^\circ\text{C}$
Storage Temperature	$T_{stg}$	-40 ~ +110	$^\circ\text{C}$
ESD Sensitivity ( $R=1.5\text{k}\Omega$ , $C=100\text{pF}$ )	$ESD_{HBM}$	2	kV
Soldering Temperature	Reflow	260 $^\circ\text{C}$ for 30sec	$^\circ\text{C}$

EVERLIGHT

### 3. Characteristics Graph

#### Wavelength Characteristics Relative Spectral Distribution

@ Ts = 25°C, If=50mA

$$\Phi_v / \Phi_v (Max.) = f(\lambda)$$

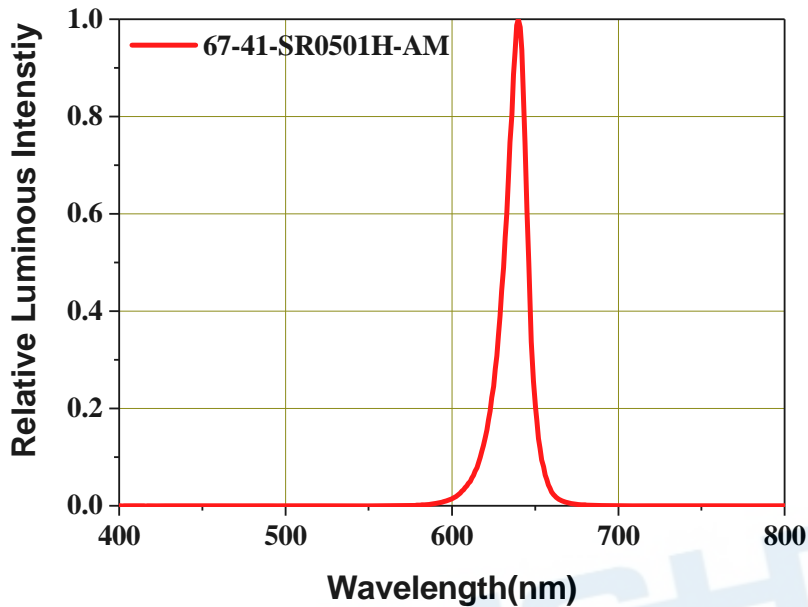

#### Typical Diagram Characteristics of Radiation

$$\Phi_v / \Phi_v (0^\circ) = f(\varphi)$$

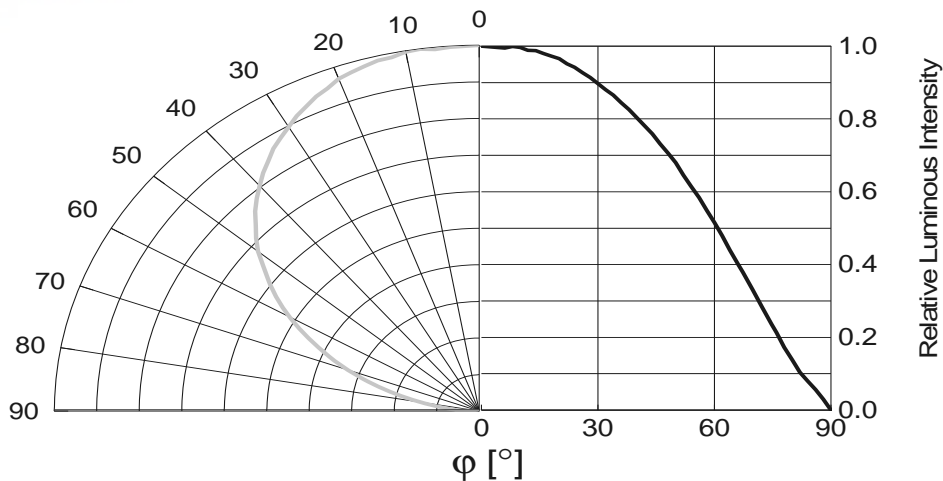

**Notes:**

1. φ is the off axis angle from lamp centerline where the luminous intensity is 1/2 of the peak value.
2. View angle tolerance is ± 5°.

**Forward Current vs. Forward Voltage**  
@ Ts = 25°C

$$I_F = f(V_F)$$

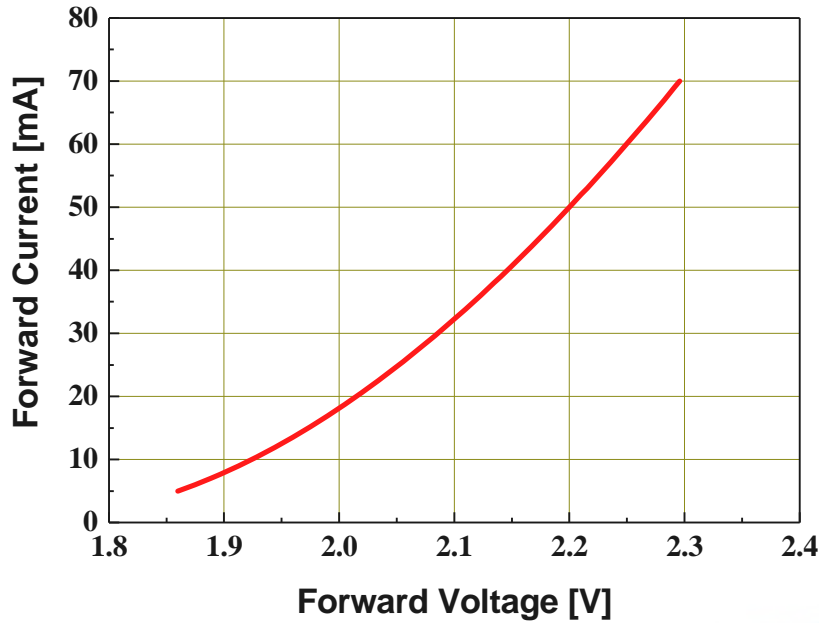

**Relative Luminous Intensity vs. Forward Current**  
@ Ts = 25°C

$$\Phi_V / \Phi_V (50mA) = f(I_F)$$

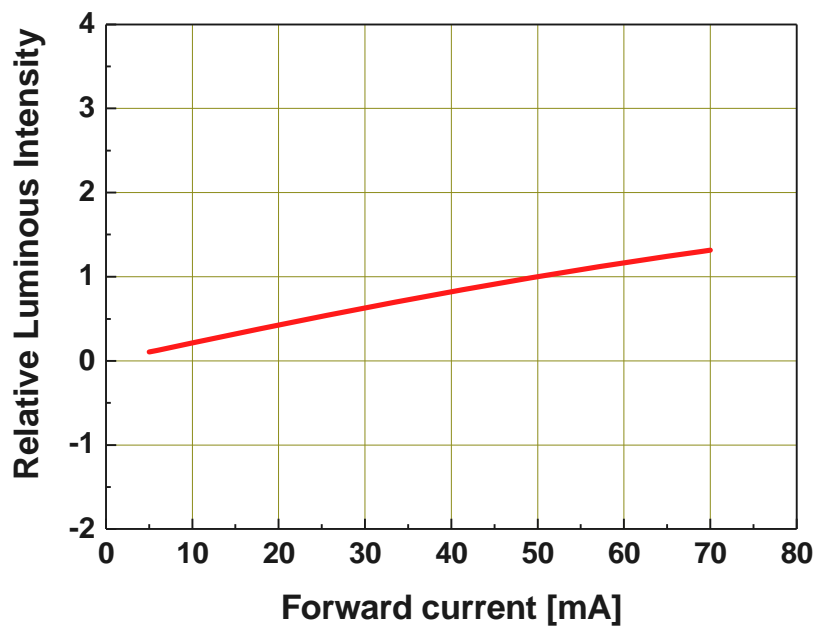

**Dominant Wavelength vs. Forward Current**  
@  $T_s = 25^\circ\text{C}$

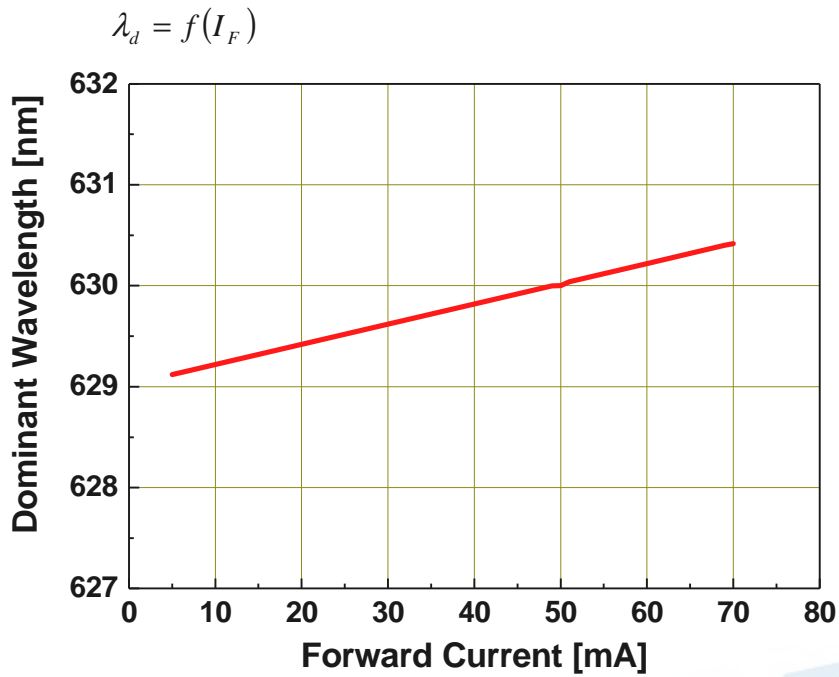

**Relative Forward Voltage vs. Junction Temperature**  
@  $I_F = 50\text{mA}$

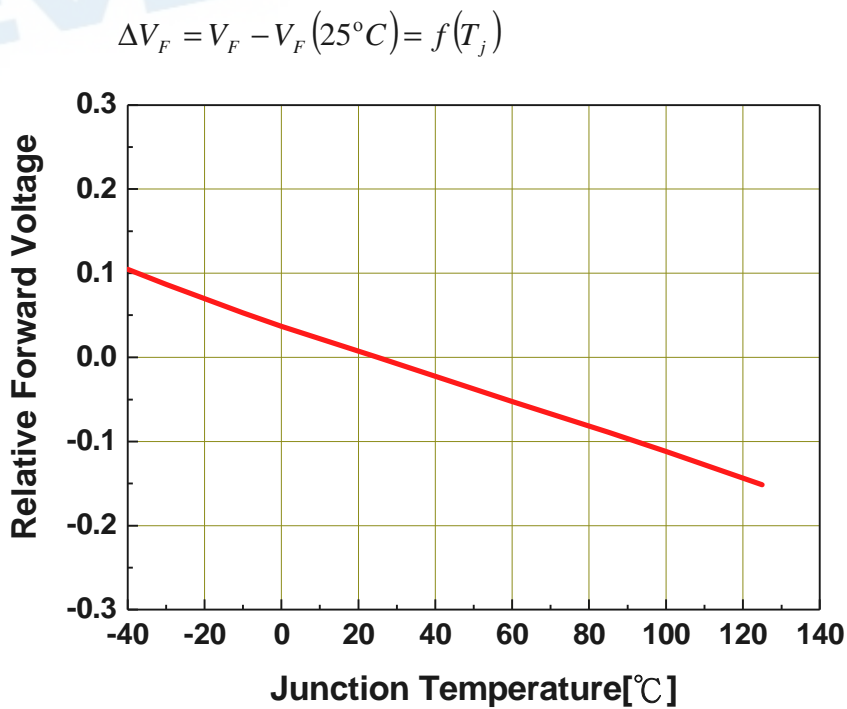

### Relative Luminous Intensity vs. Junction Temperature

@  $I_F=50\text{mA}$

$$\Phi_v / \Phi_v(25^\circ\text{C}) = f(T_j)$$

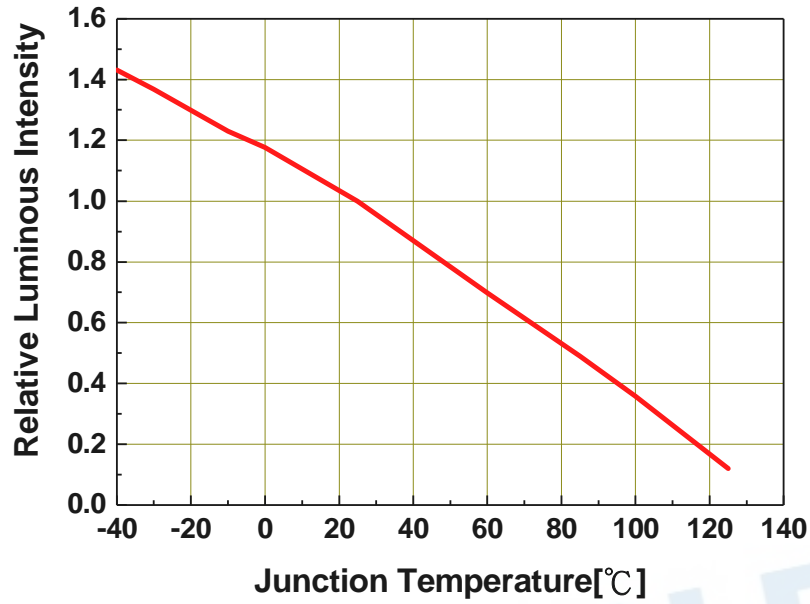

### Relative Wavelength vs. Junction Temperature

@  $I_F=50\text{mA}$

$$\Delta\lambda_d = \lambda_d - \lambda_d(25^\circ\text{C}) = f(T_j)$$

### Forward Current Derating Curve

$$I_F = f(T_S)$$

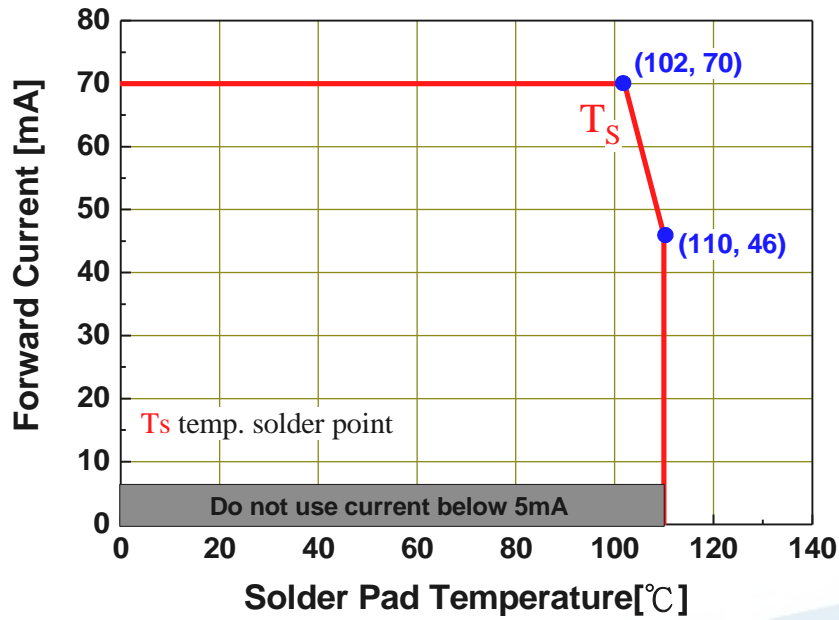

### Permissible Pulse Handling Capability

D=Duty cycle ,  $T_s = 25^\circ\text{C}$

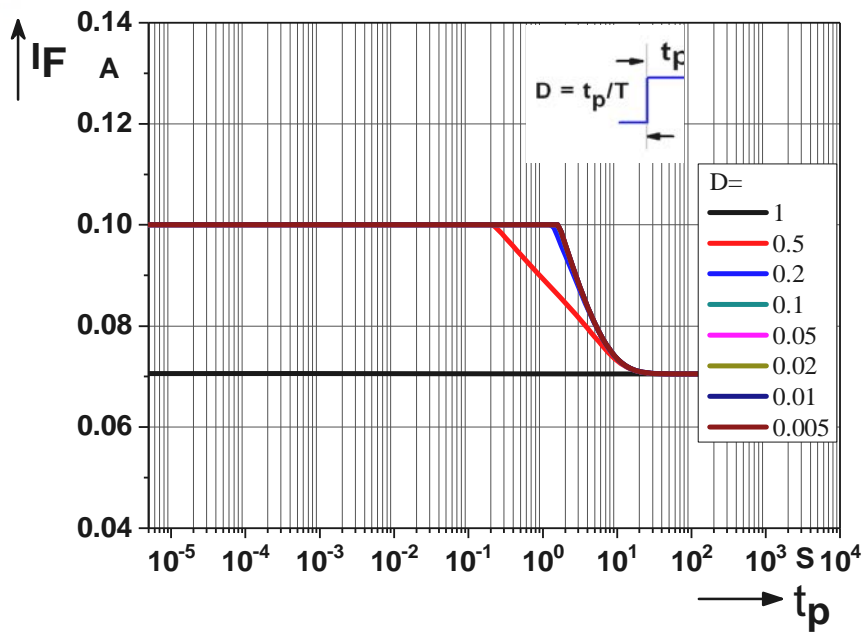

## 4. Binning Information

### Luminous Intensity Bins

Group Bin	Luminous Intensity (mcd)		Luminous flux (lm)(for reference)	
	Min.	Max.	Min.	Max.
L1	11.2	14	0.035	0.044
L2	14	18	0.044	0.057
M1	18	22.4	0.057	0.070
M2	22.4	28	0.070	0.088
N1	28	35.5	0.088	0.112
N2	35.5	45	0.112	0.142
P1	45	56	0.142	0.176
P2	56	71	0.176	0.223
Q1	71	90	0.223	0.283
Q2	90	112	0.283	0.352
R1	112	140	0.352	0.440
R2	140	180	0.440	0.566
S1	180	224	0.566	0.704
S2	224	280	0.704	0.881
T1	280	355	0.881	1.12
T2	355	450	1.12	1.42
U1	450	560	1.42	1.76
U2	560	710	1.76	2.23
V1	710	900	2.23	2.83
V2	900	1120	2.83	3.52
AA	1120	1400	3.52	4.40
AB	1400	1800	4.40	5.66
BA	1800	2240	5.66	7.04
BB	2240	2800	7.04	8.81
CA	2800	3550	8.81	11.2
CB	3550	4500	11.2	14.2
DA	4500	5600	14.2	17.6
DB	5600	7100	17.6	22.3
EA	7100	9000	22.3	28.3
EB	9000	11200	28.3	35.2
FA	11200	14000	35.2	44.0
FB	14000	18000	44.0	56.6
GA	18000	22400	56.6	70.4

#### Notes:

1. Luminous flux measurement tolerance:  $\pm 8\%$ .
2. Highlighted Black Box is possible output bins.

## Dominant Wavelength Bins

Group Bin	Minimum Dominant Wavelength [nm]	Maximum Dominant Wavelength [nm]
5963	459	463
6367	463	467
6771	467	471
7175	471	475
1015	510	515
1520	515	520
2025	520	525
2530	525	530
3035	530	535
5255	552	555
5558	555	558
5861	558	561
6164	561	564
6467	564	567
6770	567	570
7073	570	573
7376	573	576
7679	576	579
7982	579	582
8285	582	585
8588	585	588
8891	588	591
9194	591	594
9497	594	597
9700	597	600
0003	600	603
0306	603	606
0609	606	609
0912	609	612
1215	612	615
1518	615	618
1821	618	621
2124	621	624
2427	624	627
2730	627	630
3033	630	633
3336	633	636
3639	636	639

**Notes:**

1. Tolerance of Dominant Wavelength :  $\pm 1$ nm.

## Forward Voltage Bins

Bin code	Min Forward Voltage [V]	Max Forward Voltage [V]
1012	1.00	1.25
1215	1.25	1.50
1517	1.50	1.75
1720	1.75	2.00
2022	2.00	2.25
2225	2.25	2.50
2527	2.50	2.75
2730	2.75	3.00
3032	3.00	3.25
3235	3.25	3.50
3537	3.50	3.75
3740	3.75	4.00
4042	4.00	4.25
4245	4.25	4.50
4547	4.50	4.75
4750	4.75	5.00
5052	5.00	5.25
5255	5.25	5.50
5557	5.50	5.75
5760	5.75	6.00
6062	6.00	6.25
6265	6.25	6.50
6567	6.50	6.75
6770	6.75	7.00

### Notes:

1. Forward voltage measurement tolerance:  $\pm 0.05V$ .
2. Forward voltage bins are defined at  $I_F = 50mA$  operation.

## 5. Part Number

### 67-41-SR0501H-AM

Part number is designated with below details.

67-41 = Product family name.

SR = Color <sup>[1]</sup>

050 = Test current [mA]

1 = Lead Frame Type ( 0=Ag ; 1=Au)

H = Brightness Level (H=High ; M=Medium ; L=Low)

AM = Automotive application

Note

[1] Color :

Symbol	Description
C	Cool White
N	Neutral White
W	Warm White
PA	Phosphor Converted Amber
PR	Phosphor Converted Red
UB	Blue
IB	Ice Blue
SB	Sky Blue
UP	Purple
UG	Green
UY	Yellow
UYG	Brilliant Yellow Green
UPG	Pale Green
UA	Amber
UR	Red
SR	Super Red
RGB	RGB-Color
PYG	Phosphor Converted Yellow Green

## 6. Ordering Information

### 67-41-SR0501H-**ABCDEFGHIJKLM**-NO-AM

Part Number of the 67-41	Order Code
67-41-SR0501H-AM	67-41-SR0501H-ABCDEFGHIJKLM-NO-AM

Order code contains information with below details :

ABCD = min/max wavelength or CCT

EFGH = min./max. luminous flux in [lm] or luminous intensity in [mcd]

JKLM = min./max. forward voltage

NO = internal code

AM = Automotive Application

EVERLIGHT

## 7. Mechanical Dimension

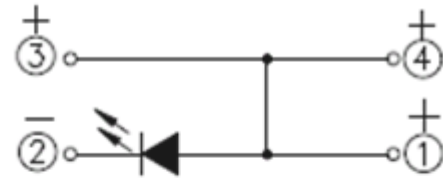
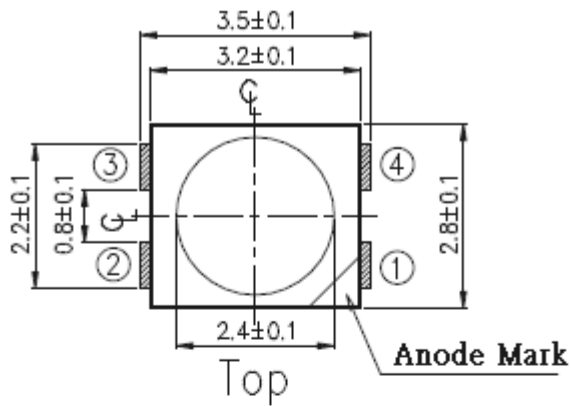

Polarity

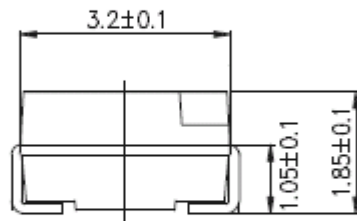

Side

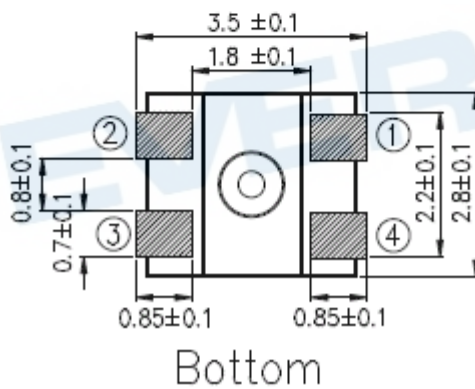

Bottom

**Notes:**

1. Dimensions are in millimeters.
2. Tolerances unless mentioned are ± 0.1mm.

## 8. Recommended Soldering Pad

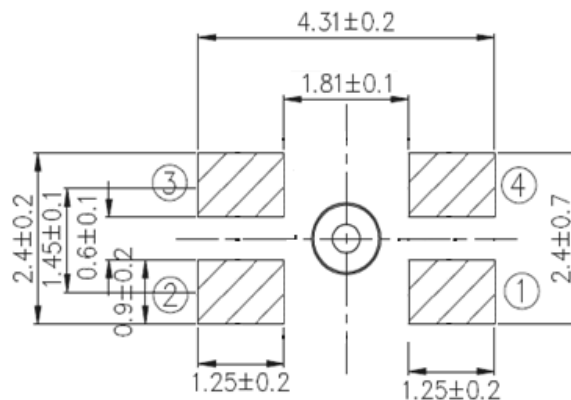

## 9. Reflow Soldering Profile

Soldering Condition (Reference: IPC/JEDEC J-STD-020D)

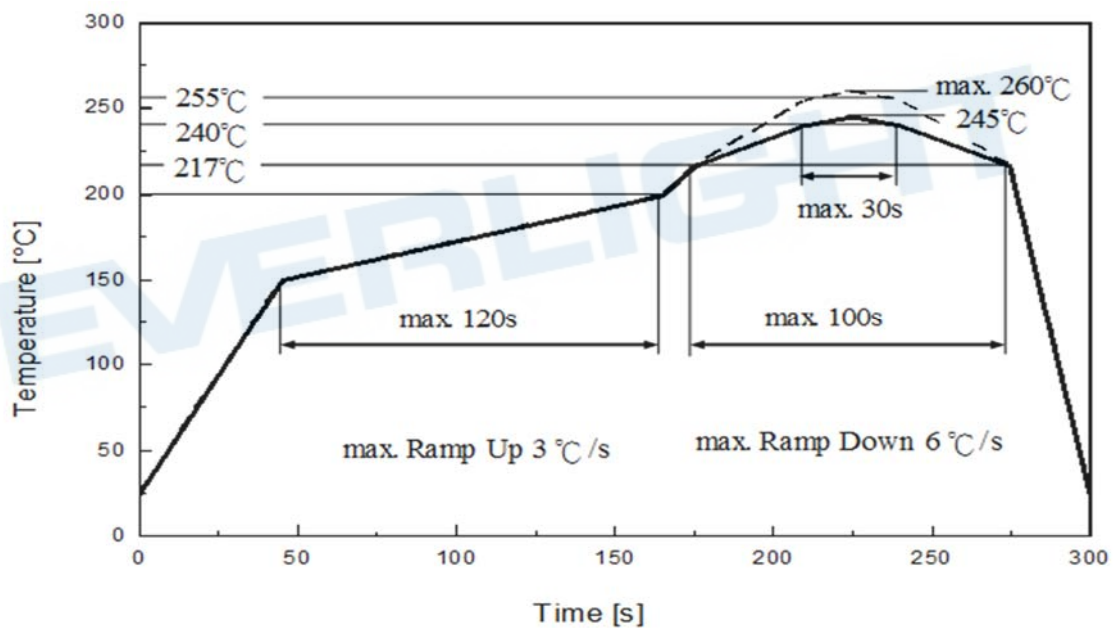

Profile Feature	Pb-Free Assembly	Unit
	Recommendation	
Ramp-up rate to preheat 25 °C to 150 °C	3	°C /sec
Time of soaking zone 150 °C to 200 °C	120	sec
Ramp-up rate to peak	3	°C /sec
Liquidus temperature	217	°C
Time above liquidus temperature	100	sec
Peak temperature (max.)	260	°C
Time within 5°C of the specified peak temperature	30	sec
Ramp-down Rate (max.)	6	°C /sec

## 10. Packaging Information

### ● Product Labeling



- CPN : Customer's Product Number
- P/N : Everlight Part Number
- QTY : Packing Quantity
- CAT : Luminous Flux (Brightness) Bin
- HUE : Color Bin
- REF : Forward Voltage Bin
- LOT No : Lot Number

### ● Packing: Loaded Quantity 2000 pcs Per Reel

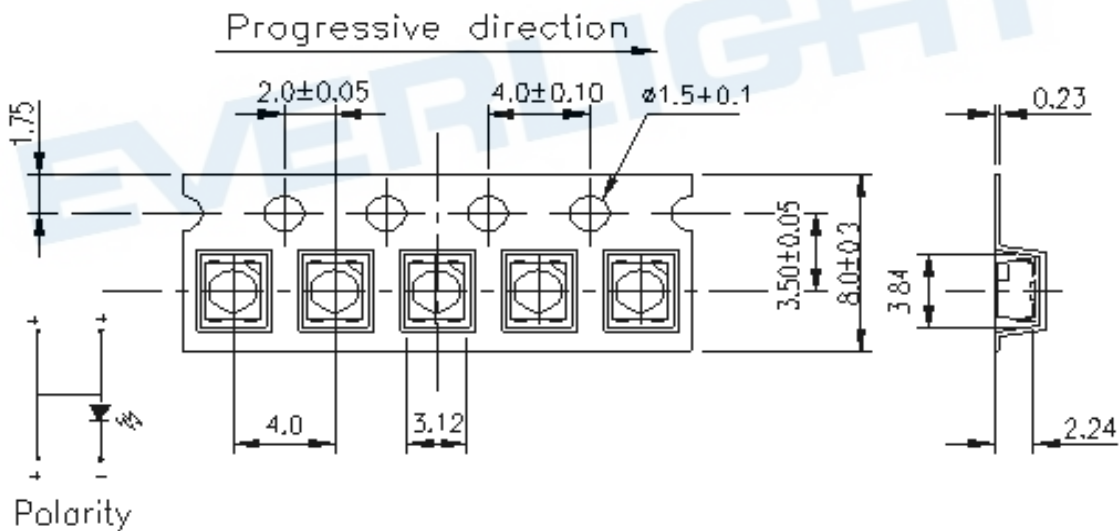

#### Notes:

1. Dimensions are in millimeters.

● **Reel Dimensions**

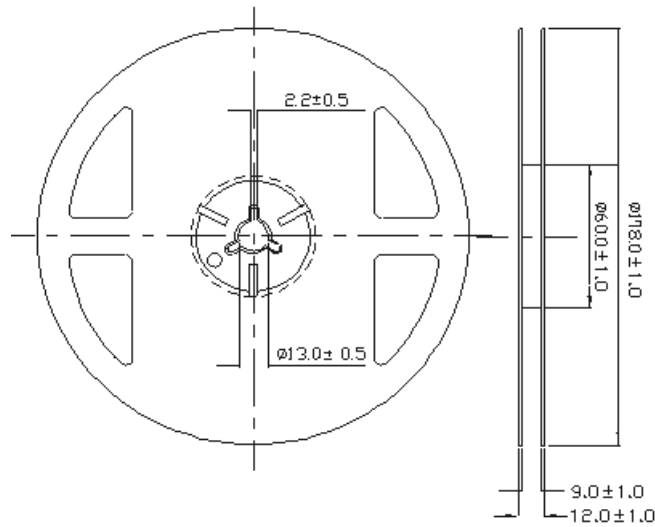

**Notes:**

1. Dimensions are in millimeters.

● **Moisture Resistant Packing Process**

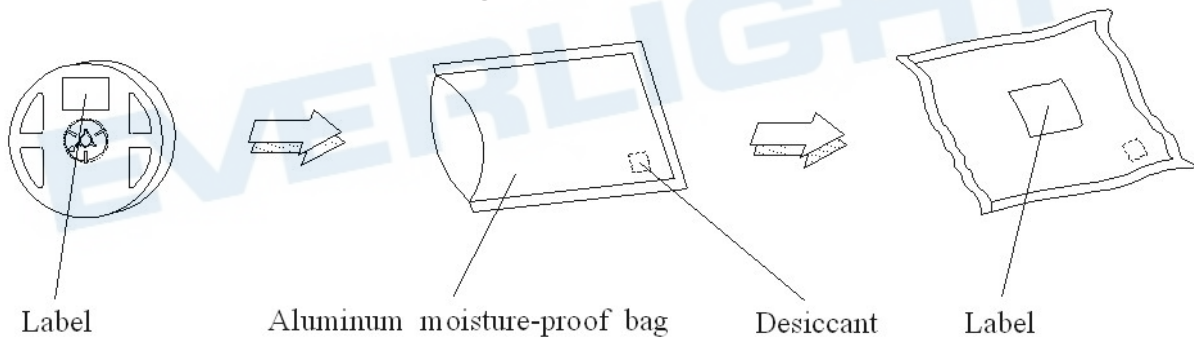

## 11. Precaution for Use

### 1. Over-current-proof

Customer must apply resistors for protection; otherwise slight voltage shift will cause big current change (burn out will happen).

### 2. Assemblies

Do not stack assemblies containing LEDs to prevent damage to the optical surface of LEDs. Forces applied to the optical surface may result in the surface being damaged.

### 3. Soldering Condition

3.1 When soldering, do not put stress on the LEDs during heating.

3.2 After soldering, do not warp the circuit board.

### 4. Soldering Iron

Each terminal is to go to the tip of soldering iron temperature less than 350°C for 3 seconds within once in less than the soldering iron capacity 25W. Leave two seconds and more intervals, and do soldering of each terminal. Be careful because the damage of the product is often started at the time of the hand solder.

### 5. Repairing

Repair should not be done after the LEDs have been soldered. When repairing is unavoidable, a double-head soldering iron should be used (as below figure). It should be confirmed beforehand whether the characteristics of the LEDs will or will not be damaged by repairing.

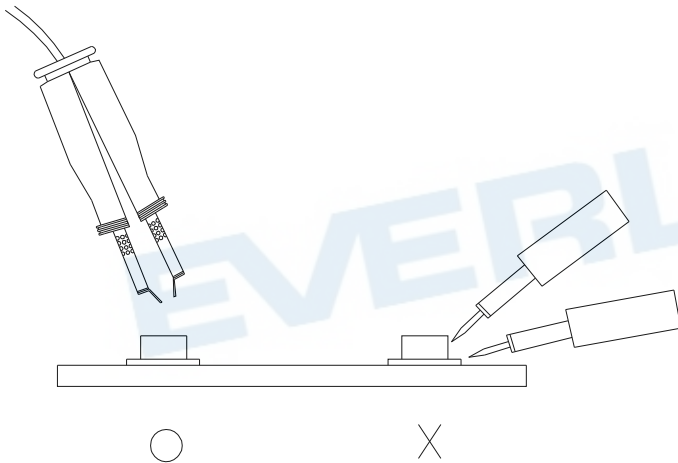

## 12. Sulfur Test Criteria

Products	Failure Criteria			
Exterior Lighting products	Luminous Flux +/-20%, forward voltage +/-10%, color coordinates x,y +/-0.01, color wavelength +/- 2 nm Visual defect issue following Everlight's inspection criteria			
Interior lighting products	Luminous Flux +/-30% or +/-50% for some application, forward voltage +/-10%, color coordinates x,y +/-0.02, color wavelength +/- 2 nm Visual defect issue following Everlight's inspection criteria			
Grade of H2S and FMG test	Please refer to the table as below. As for discolor, please refer to the Frame blackening after Grade of H2S and FMG test defect under Everlight's inspection criteria			
	Grade A0	Grade A1	Grade B0	Grade B1
C12 H2S Class A C13 FMG	No corrosion	Corrosion without the impact on reliability and life time, following AEC-Q102 rev. A		
C12 H2S Class B C13 FMG			No corrosion	Corrosion without the impact on reliability and life time, following AEC-Q102 rev. A

Class for H2S Test & FMG	Description	
	H2S	FMG
Class A	15 ppm with duration 336 h at 40 °C and 90% RH.	Duration 500 h at 25 °C and 75% RH. H2S concentration: 10ppb SO2 concentration: 200ppb NO2 concentration: 200ppb Cl2 concentration: 10ppb
Class B	10 ppm with duration 500 h at 25 °C and 75% RH.	

Class for H2S Test & FMG	Description
0	No corrosion found
1	Corrosion without the impact on reliability and life time, following AEC-Q102 rev. A

## Revision History

Current version: 25.Dec.2024

Issue No: DSE-0016897

Version: 9

Created by: Penliang Hu

Rev.	Subjects (major change in previous version)	Modified date
1	Approved	2016/09/07
2	Part Number is 67-41-SR0501H-AM	2016/12/30
3	Add MSL, surge current, Permissible Pulse Handling Capability fig	2017/06/02
4	Modify Operating Temperature & Storage Temperature, Order Code, Luminous Intensity, Dominant Wavelength	2017/08/22
5	Modify $R_{th JS real}$ & $R_{th JS el}$	2018/01/11
6	Revise Luminous Intensity & Forward Voltage	2021/08/04
7	Intensity Bins add $I_m$ data	2023/08/16
8	Add Sulfur Test Criteria, Revise AEC-Q102 condition	2024/01/16
9	Revise partial odd graph	2024/12/25