

## SMD ■ Power Top LEDs with Lens 67-31J-R9ND-A0DAFBC7G-BT8-CS



### Features

- PLCC-3 package.
- .High flux output.
- .High current capability.
- .White package.
- .Optical indicator.
- .Ideal for backlight and light pipe application.
- .Inter reflector.
- .Wide viewing angle.
- .Suitable for automatic placement equipment.
- .Suitable for reflow and wave solder processes.
- .Available on tape and reel (8mm Tape).
- .Pb-free.
- .The product itself will remain within RoHS compliant version.

### Applications

- .Indicator and backlight for audio and video equipment.
- .Indicator and backlight in office and family equipment.
- .Flat backlight for LCD's, switches and symbols.
- .Light pipe application.
- .General use.

## Device Selection Guide

Chip Materials	Emitted Color	Resin Color
AlGaInP	Super-Red	Diffused

## Absolute Maximum Ratings (Ta=25°C)

Parameter	Symbol	Rating	Unit
Reverse Voltage	$V_R$	12	V
Forward Current	$I_F$	50	mA
Peak Forward Current (Duty 1/10 @1KHz)	$I_{FP}$	100	mA
Power Dissipation	$P_d$	125	mW
Junction Temperature	$T_j$	125	°C
Operating Temperature	$T_{opr}$	-40 ~ +85	°C
Storage Temperature	$T_{stg}$	-40 ~ +90	°C
Thermal Resistance	$R_{th\ J-A}$	300	K/W
	$R_{th\ J-S}$	150	K/W
ESD (Classification acc. AEC Q101)	$ESD_{HBM}$	2000	V
	$ESD_{MM}$	200	V
Soldering Temperature	$T_{sol}$	Reflow Soldering : 260 °C for 10 sec. Hand Soldering : 350 °C for 3 sec.	

**Electro-Optical Characteristics (Ta=25°C)**

Parameter	Symbol	Min.	Typ.	Max.	Unit	Condition
Luminous Intensity	I <sub>v</sub>	4500	-----	18000	mcd	I <sub>F</sub> =50mA
Viewing Angle	2θ <sub>1/2</sub>	-----	30	-----	deg	I <sub>F</sub> =50mA
Peak Wavelength	λ <sub>p</sub>	-----	632	-----	nm	I <sub>F</sub> =50mA
Dominant Wavelength	λ <sub>d</sub>	617.5	-----	633.5	nm	I <sub>F</sub> =50mA
Spectrum Radiation Bandwidth	Δλ	-----	20	-----	nm	I <sub>F</sub> =50mA
Forward Voltage	V <sub>F</sub>	1.7	-----	2.5	V	I <sub>F</sub> =50mA
Reverse Current	I <sub>R</sub>	-----	-----	5	μA	V <sub>R</sub> =-10V

Note:

1. Tolerance of Luminous Intensity: ±11%
2. Tolerance of Dominant Wavelength: ±1nm
3. Tolerance of Forward Voltage: ±0.1V

EVERLIGHT

### Bin Range of Luminous Intensity

Bin Code	Min.	Max.	Unit	Condition
DA	4500	5600	mcd	I <sub>F</sub> =50mA
DB	5600	7100		
EA	7100	9000		
EB	9000	11200		
FA	11200	14000		
FB	14000	18000		

Note:  
 Tolerance of Luminous Intensity: ±11%

### Bin Range of Dominant Wavelength

Bin Code	Min.	Max.	Unit	Condition
E4	617.5	621.5	nm	I <sub>F</sub> =50mA
E5	621.5	625.5		
E6	625.5	629.5		
E7	629.5	633.5		

Note:  
 Tolerance of Dominant Wavelength: ±1nm

### Bin Range of Forward Voltage

Bin Code	Min.	Max.	Unit	Condition
C7-1	1.7	1.9	V	I <sub>F</sub> =50mA
C7-2	1.9	2.1		
C7-3	2.1	2.3		
C7-4	2.3	2.5		

Note:  
 Tolerance of Forward Voltage: ±0.1V

## Typical Electro-Optical Characteristics Curves

### Typical Curve of Spectral Distribution

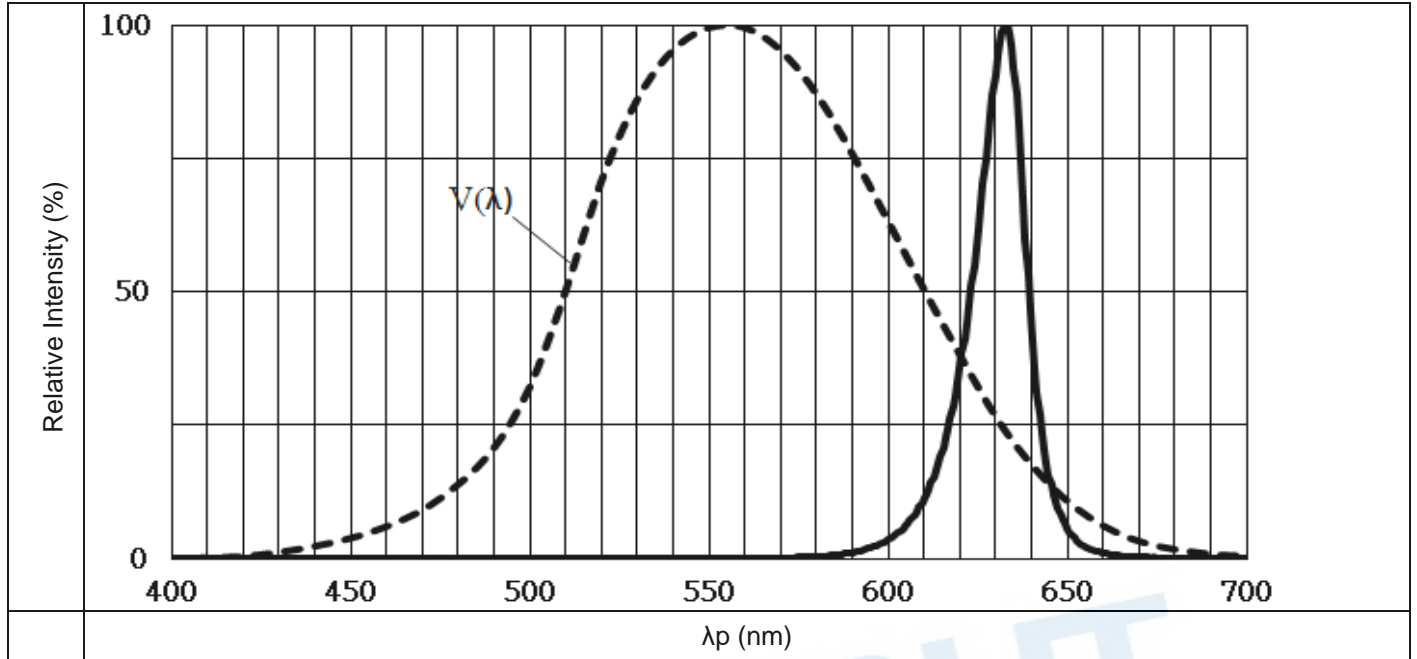

Note:  $V(\lambda)$ =Standard eye response curve;  $I_f = 50\text{mA}$

### Diagram Characteristics of Radiation

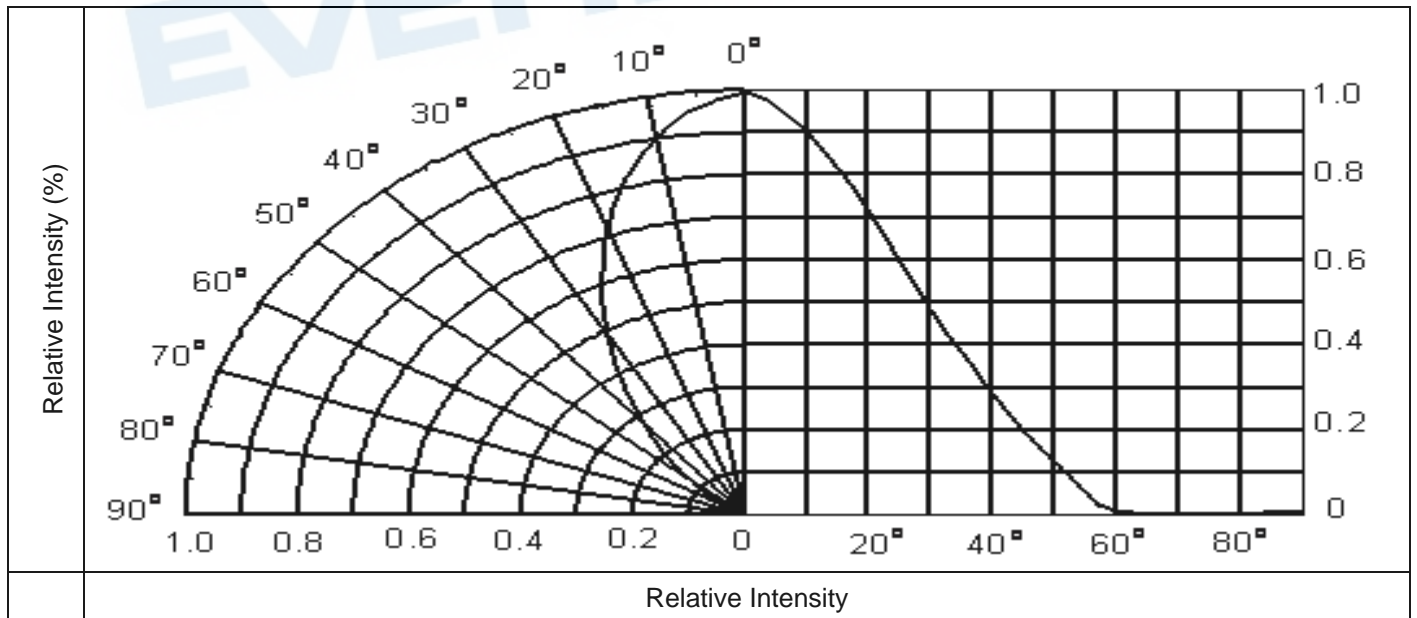

Forward Current vs. Forward Voltage (Ta=25°C)

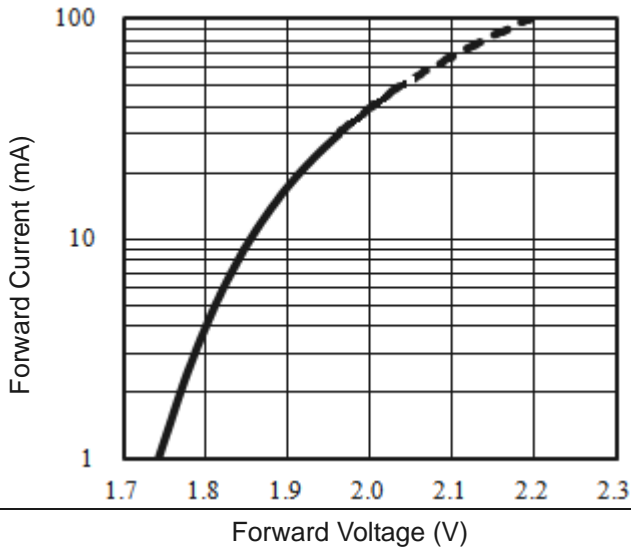

Dominant Wavelength vs. Forward Current (Ta=25°C)

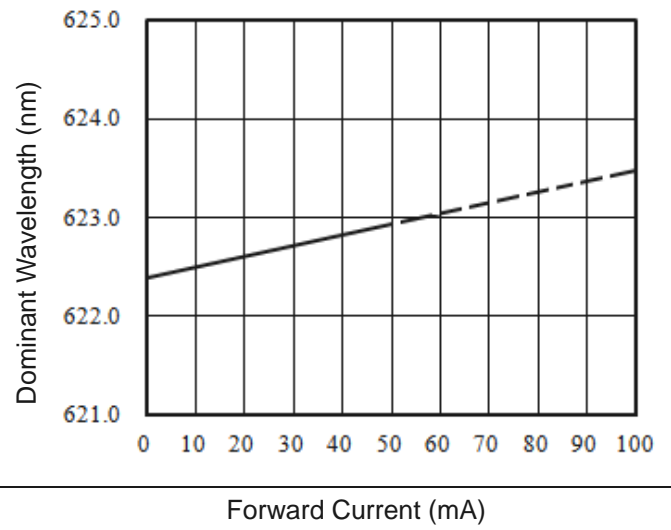

Relative Luminous Intensity vs. Forward Current (Ta=25°C)

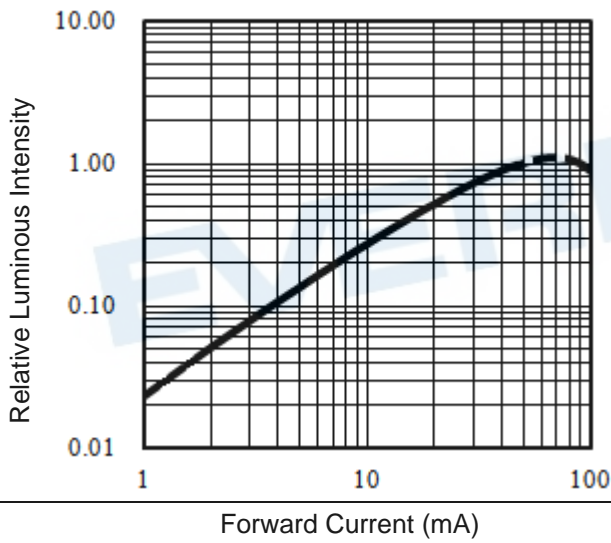

Max. Permissible Forwarded Current (Ta=25°C)

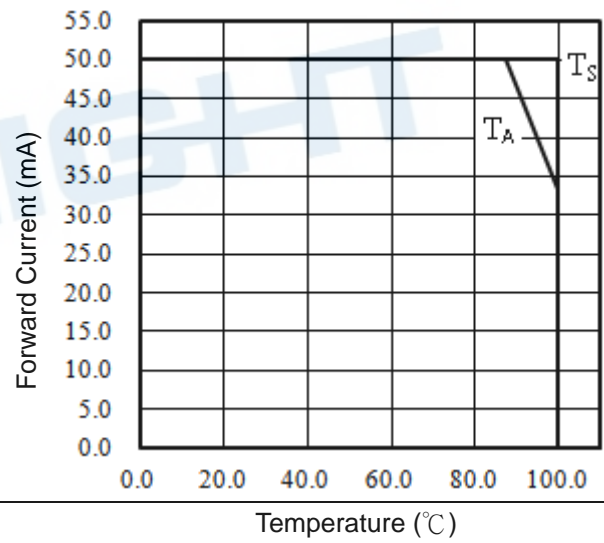

Package Dimension

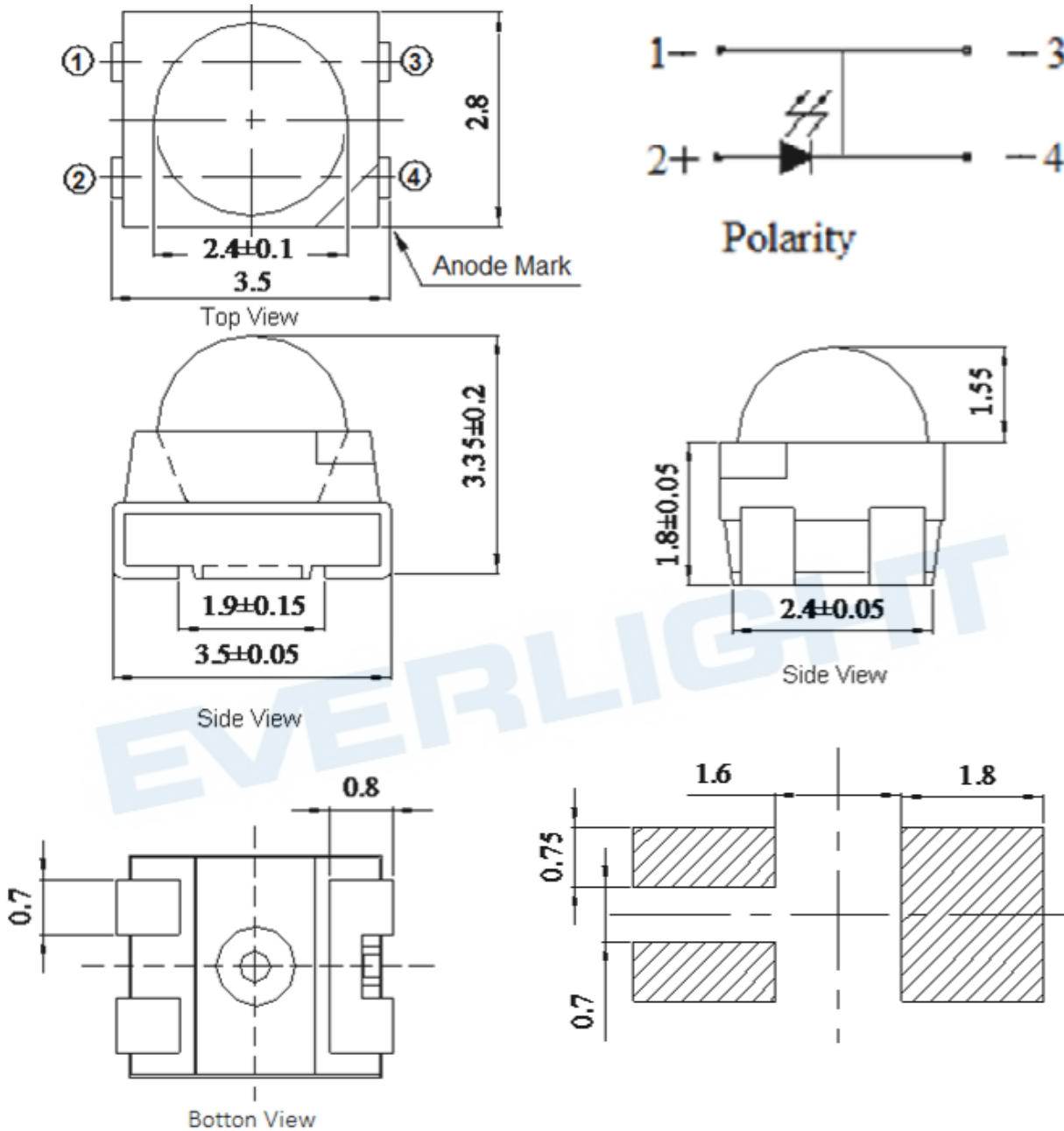

Note: Tolerances unless mentioned ±0.1mm. Unit = mm

Moisture Resistant Packing Materials

Label Explanation

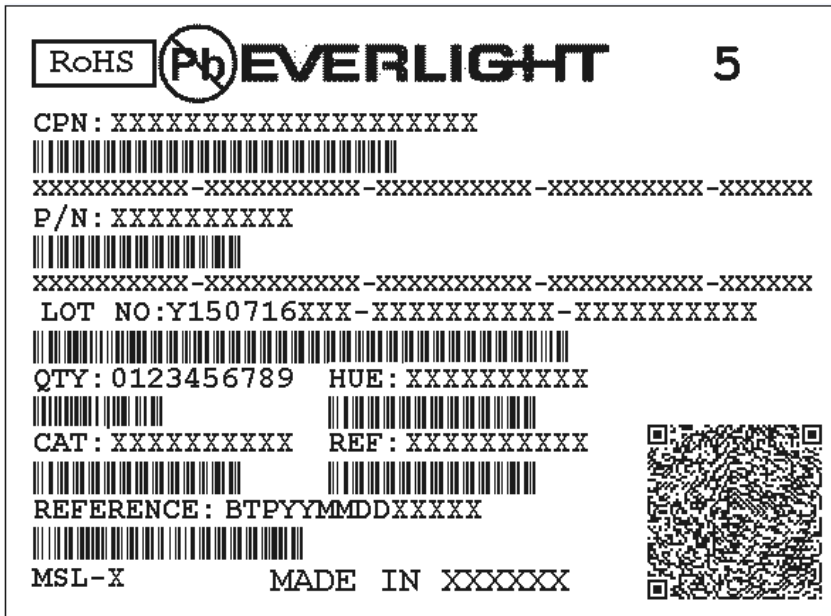

- CPN: Customer's Product Number
- P/N: Product Number
- QTY: Packing Quantity
- CAT: Luminous Intensity Rank
- HUE: Dom. Wavelength Rank
- REF: Forward Voltage Rank
- LOT No: Lot Number

Reel Dimensions

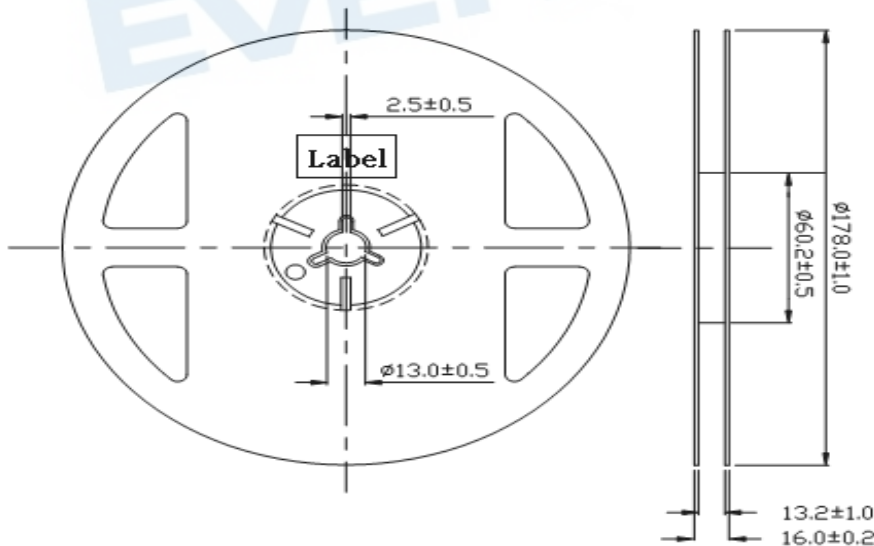

**Carrier Tape Dimensions: Loaded Quantity 500 pcs Per Reel**

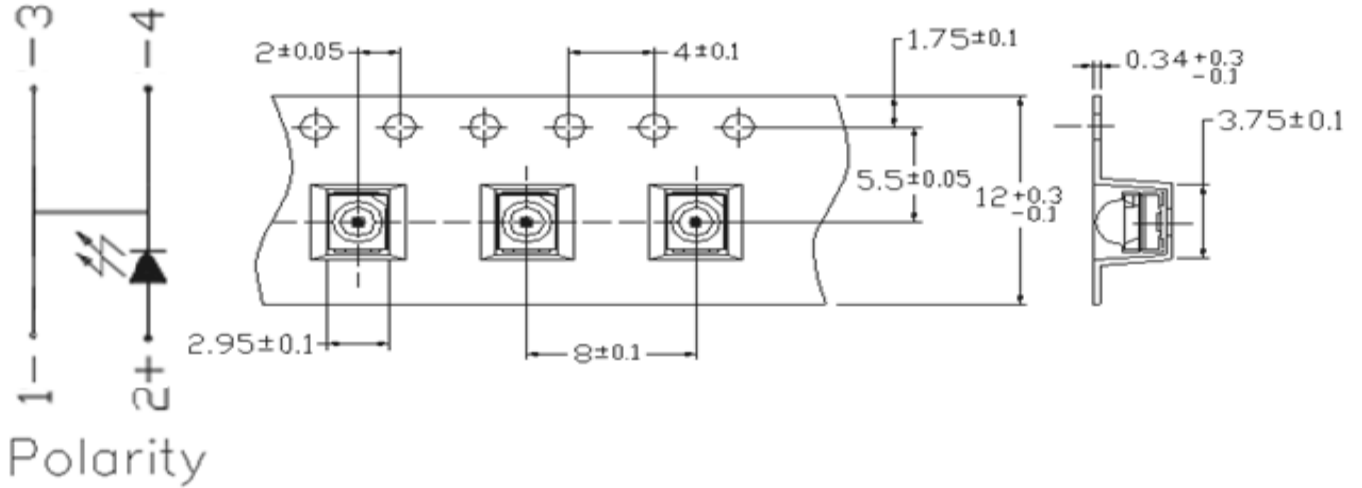

Note: Tolerances unless mentioned  $\pm 0.1$ mm. Unit = mm

**Moisture Resistant Packing Process**

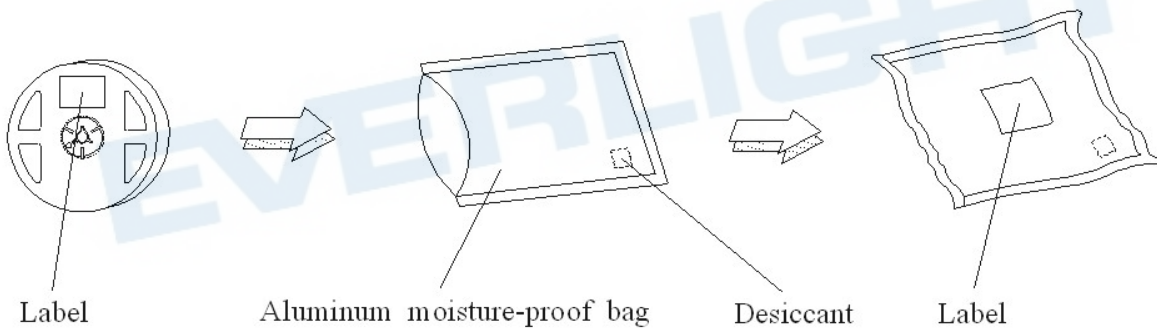

Note: Tolerances unless mentioned  $\pm 0.1$ mm. Unit = mm

## Precautions for Use

### 1. Over-current-proof

1.1 Customer must apply resistors for protection, otherwise slight voltage shift will cause big current change ( Burn out will happen ).

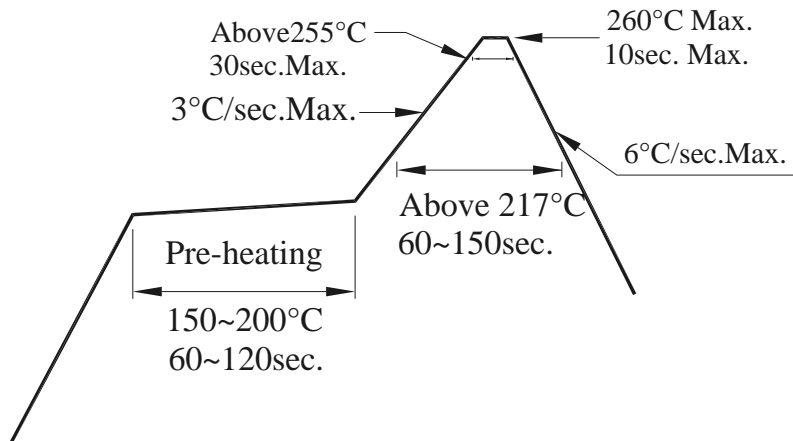

Note: Reference: IPC/JEDEC J-STD-020D

### 2. Storage

- 2.1 Moisture proof bag should only be opened immediately prior to usage.
- 2.2 Environment should be less than 30°C and 60% RH when moisture proof bag is opened.
- 2.3 After opening the package MSL Conditions stated on page 1 of this spec should not be exceeded.
- 2.4 If the moisture sensitivity card indicates higher than acceptable moisture, the component should be baked at min. 60deg +/-5deg for 24 hours.

### 3. Soldering Condition

- 3.1 Pb-free solder temperature profile
- 3.2 Reflow soldering should not be done more than two times.
- 3.3 When soldering, do not put stress on the LEDs during heating.
- 3.4 After soldering, do not warp the circuit board.

### 4. Soldering Iron

Each terminal is to go to the tip of soldering iron temperature less than 350°C for 3 seconds within once in less than the soldering iron capacity 25W. Leave two seconds and more intervals, and do soldering of each terminal. Be careful because the damage of the product is often started at the time of the hand solder.

### 5. Repairing

Repair should not be done after the LEDs have been soldered. When repairing is unavoidable, a double-head soldering iron should be used (as below figure). It should be confirmed beforehand whether the characteristics of the LEDs will or will not be damaged by repairing.

## Application Restrictions

High reliability applications such as military/aerospace, automotive safety/security systems, and medical equipment may require different product. If you have any concerns, please contact Everlight before using this product in your application. This specification guarantees the quality and performance of the product as an individual component. Do not use this product beyond the specification described in this document.

## DISCLAIMER

1. EVERLIGHT reserves the right(s) on the adjustment of product material mix for the specification.
2. The product meets EVERLIGHT published specification for a period of twelve (12) months from date of shipment.
3. The graphs shown in this datasheet are representing typical data only and do not show guaranteed values.
4. When using this product, please observe the absolute maximum ratings and the instructions for using outlined in these specification sheets. EVERLIGHT assumes no responsibility for any damage resulting from the use of the product which does not comply with the absolute maximum ratings and the instructions included in these specification sheets.
5. These specification sheets include materials protected under copyright of EVERLIGHT. Reproduction in any form is prohibited without obtaining EVERLIGHT's prior consent.
6. This product is not intended to be used for military, aircraft, automotive, medical, life sustaining or life saving applications or any other application which can result in human injury or death. Please contact authorized Everlight sales agent for special application request.