

Technical Data Sheet
Power Top View LEDs

67-31E/T2C-VW1X2MZ3/2T

Features

- PLCC-3 package.
- High flux output.
- High current capability.
- White package.
- Optical indicator.
- Colorless clear window.
- Ideal for backlight and light pipe application.
- Inter reflector.
- Wide viewing angle.
- Suitable for automatic placement equipment.
- Suitable for reflow and wave solder processes.
- Available on tape and reel (8mm Tape).
- Pb-free.
- The product itself will remain within RoHS compliant version.



Descriptions

The white LED which was fabricated using a blue LED and a phosphor, and the phosphor is excited by blue light and emits yellow fluorescence.

The mixture of blue light and yellow light results in a white emission.

Applications

- Indicator and backlight for audio and video equipment.
- Indicator and backlight in office and family equipment.
- Flat backlight for LCD's, switches and symbols.
- Light pipe application.
- General use.

Device Selection Guide

Chip	Emitted Color	Resin Color
Material		
InGaN	Pure White	Water Clear

Technical Data Sheet
Power Top View LEDs

67-31E/T2C-VW1X2MZ3/2T

Package Dimensions

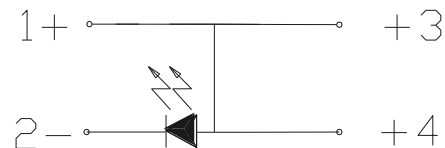
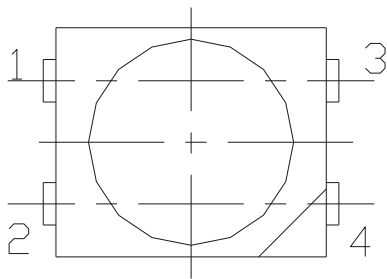

Polarity

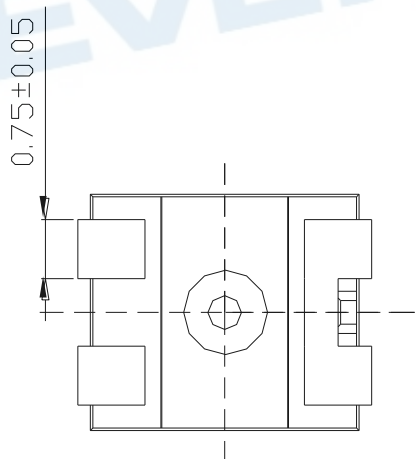
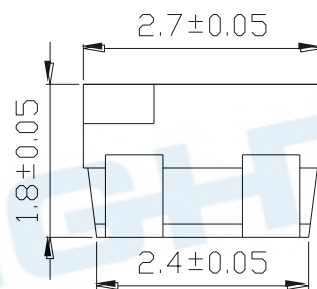
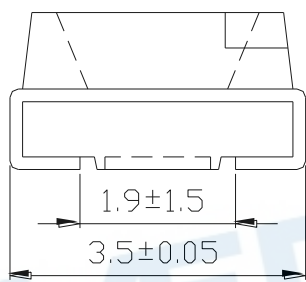

for reflow
soldering (propose)

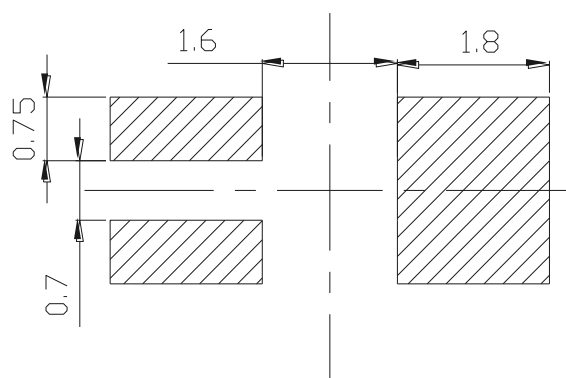

Note: The tolerance unless mentioned is ± 0.1 mm ,Unit = mm

Technical Data Sheet

Power Top View LEDs

67-31E/T2C-VW1X2MZ3/2T

Absolute Maximum Ratings (Ta=25°C)

Parameter	Symbol	Rating	Unit
Reverse Voltage	V _R	5	V
Forward Current	I _F	30	mA
Peak Forward Current (Duty 1/10 @1KHz)	I _{FP}	100	mA
Power Dissipation	P _d	110	mW
Electrostatic Discharge(HBM)	ESD	1000	V
Operating Temperature	T _{opr}	-40 ~ +85	°C
Storage Temperature	T _{stg}	-40 ~ +100	°C
Soldering Temperature	T _{sol}	Reflow Soldering : 260 °C for 10 sec. Hand Soldering : 350 °C for 3 sec.	

Electro-Optical Characteristics (Ta=25°C)

Parameter	Symbol	Min.	Typ.	Max.	Units	Condition
Luminous Intensity	I _v	1120	-----	2800	mcd	I _F =30mA
Viewing Angle	2θ 1/2	-----	120	-----	deg	I _F =30mA
Forward Voltage	V _F	2.75	-----	3.95	V	I _F =30mA
Reverse Current	I _R	-----	-----	50	μA	V _R =5V

Note:

1. Tolerance of Luminous Intensity: ±11%
2. Tolerance of Forward Voltage: ±0.1V

Technical Data Sheet
Power Top View LEDs**67-31E/T2C-VW1X2MZ3/2T****Bin Range of Luminous Intensity**

Bin	Min.	Max.	Unit	Condition
W1	1120	1420	mcd	I _F =30mA
W2	1420	1800		
X1	1800	2250		
X2	2250	2800		

Bin Range of Forward Voltage

Groups	Bin	Min.	Max.	Unit	Condition
M	5	2.75	3.05	V	I _F =30mA
	6	3.05	3.35		
	7	3.35	3.65		
	8	3.65	3.95		

Notes:

1. Tolerance of Luminous Intensity: $\pm 11\%$
2. Tolerance of Forward Voltage: $\pm 0.1V$

Technical Data Sheet
Power Top View LEDs

67-31E/T2C-VW1X2MZ3/2T

Bin Range of Chromaticity Coordinates

($I_F=30mA$)

Group	Bin Code	CIE_x	CIE_y	Bin Code	CIE_x	CIE_y
V	5K	0.2960	0.2590	5L	0.2910	0.2680
		0.2910	0.2680		0.2850	0.2790
		0.3100	0.2970		0.3070	0.3120
		0.3130	0.2840		0.3100	0.2970
	6K	0.3130	0.2840	6L	0.3100	0.2970
		0.3100	0.2970		0.3070	0.3120
		0.3300	0.3300		0.3300	0.3470
		0.3300	0.3100		0.3300	0.3300

Note: Tolerance of the Chromaticity Coordinates: ± 0.01

The CIE 1931 Chromaticity Diagram

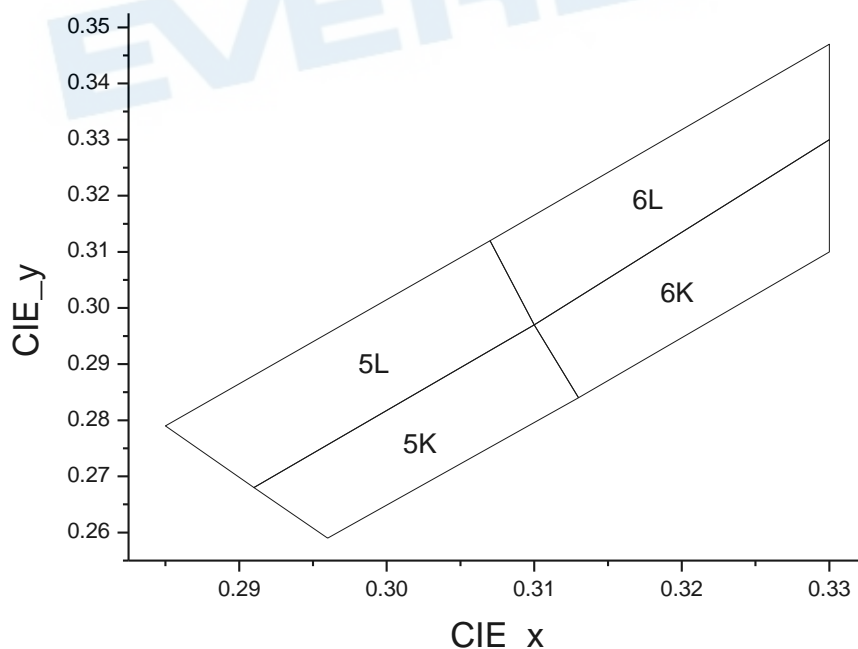

Technical Data Sheet
Power Top View LEDs

67-31E/T2C-VW1X2MZ3/2T

Typical Electro-Optical Characteristic Curves

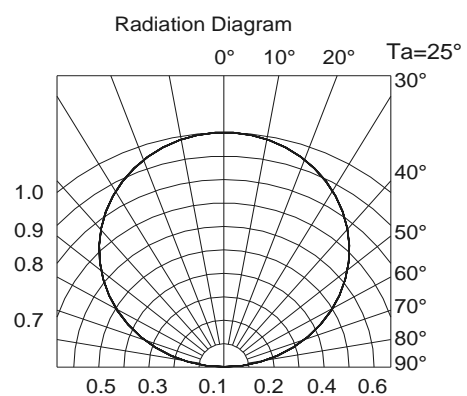
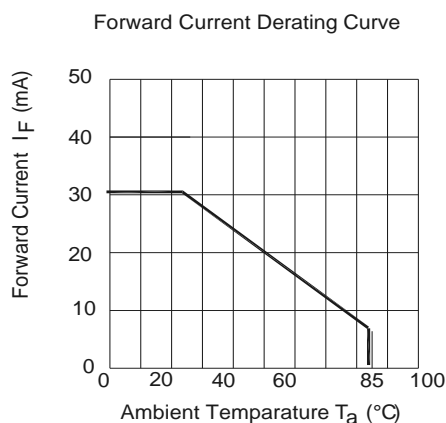
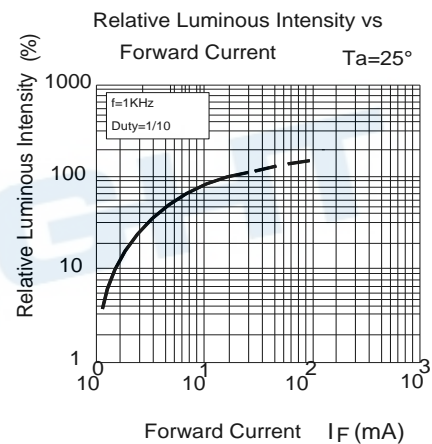
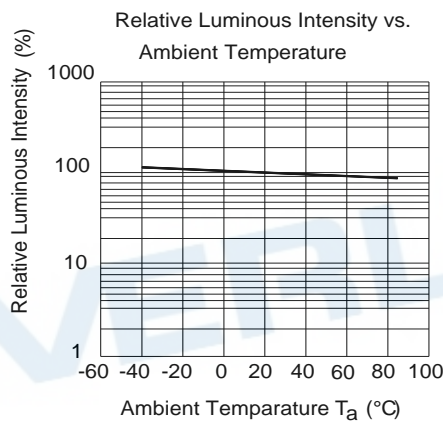
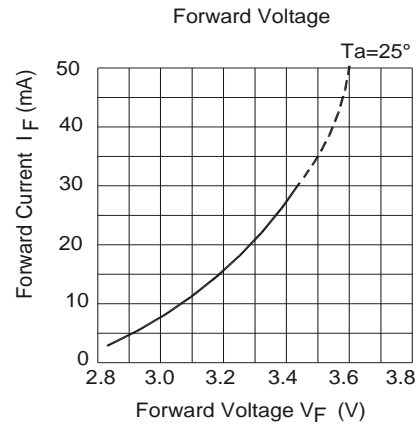
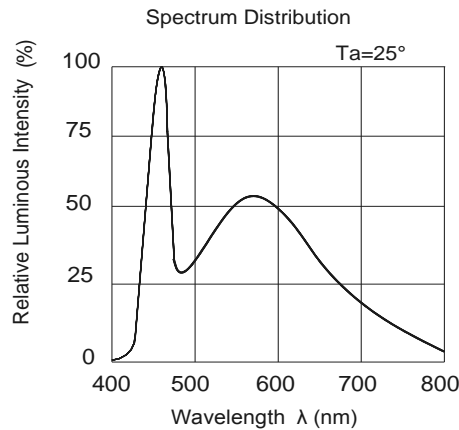

Technical Data Sheet
Power Top View LEDs

67-31E/T2C-VW1X2MZ3/2T

Label Explanation

CAT: Luminous Intensity Rank
 HUE: Dom. Wavelength Rank
 REF: Forward Voltage Rank



Reel Dimensions

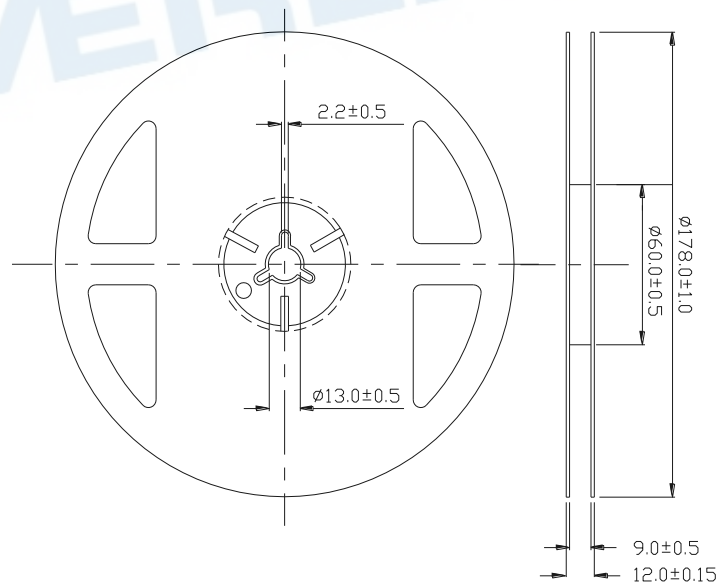

Note: The tolerance unless mentioned is ± 0.1 mm, Unit = mm

Technical Data Sheet
Power Top View LEDs

67-31E/T2C-VW1X2MZ3/2T

Carrier Tape Dimensions: Loaded Quantity 2000 pcs Per Reel

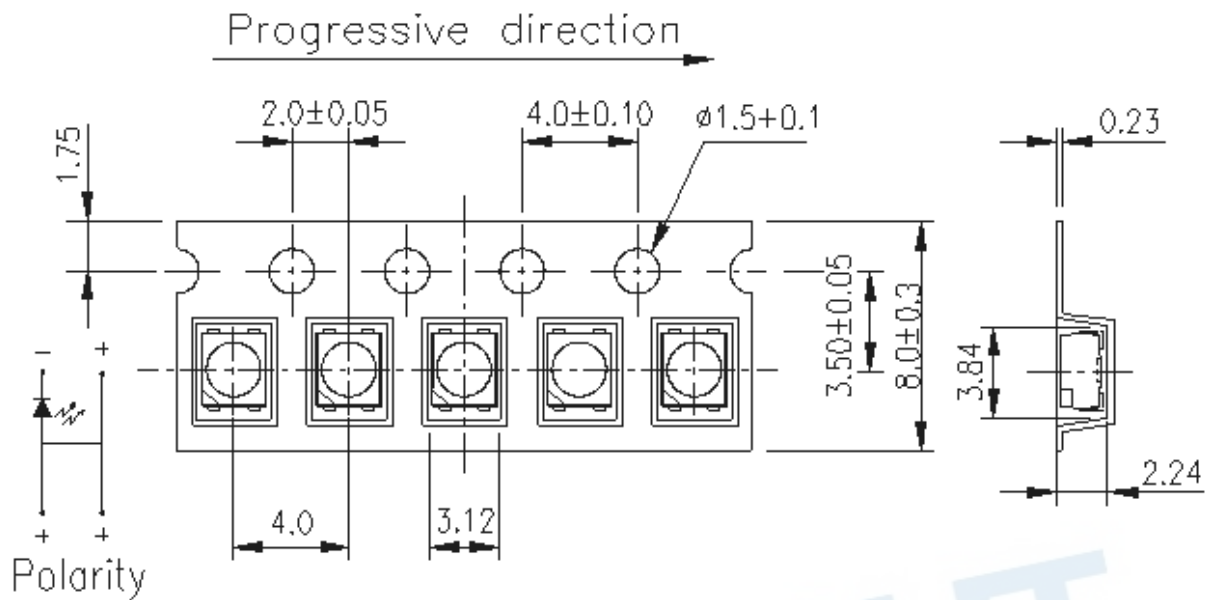

Note: Tolerance Unless Dimension $\pm 0.1\text{mm}$ Unit = mm

Moisture Resistant Packaging

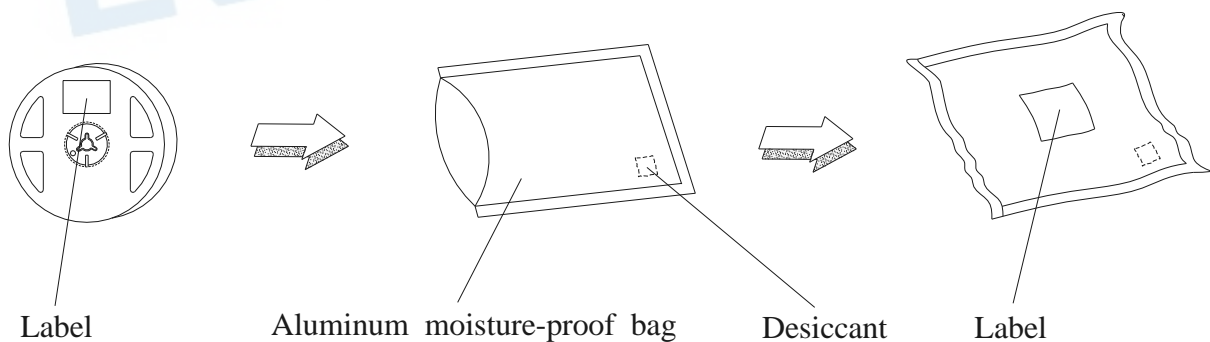

Technical Data Sheet

Power Top View LEDs

67-31E/T2C-VW1X2MZ3/2T

Reliability Test Items and Conditions

The reliability of products shall be satisfied with items listed below.

Confidence level : 90%

LTPD : 10%

No.	Items	Test Condition	Test Hours/Cycles	Sample Size	Ac/Re
1	Reflow Soldering	Temp. : 260°C±5°C Max. 10 sec.	6 Min.	22 PCS	0/1
2	Temperature Cycle	H : +100°C 15min ↓ 5 min L : -40°C 15min	300 Cycles	22 PCS.	0/1
3	Thermal Shock	H : +100°C 5min ↓ 10 sec L : -10°C 5min	300 Cycles	22 PCS.	0/1
4	High Temperature Storage	Temp. : 100°C	1000 Hrs.	22 PCS.	0/1
5	Low Temperature Storage	Temp. : -40°C	1000 Hrs.	22 PCS.	0/1
6	DC Operating Life	I _F = 20 mA / 25°C	1000 Hrs.	22 PCS.	0/1
7	High Temperature / High Humidity	85°C/85%RH	1000 Hrs.	22 PCS.	0/1

Technical Data Sheet
Power Top View LEDs

67-31E/T2C-VW1X2MZ3/2T

Precautions For Use

1. Over-current-proof

Customer must apply resistors for protection, otherwise slight voltage shift will cause big current change (Burn out will happen).

2. Storage

2.1 Do not open moisture proof bag before the products are ready to use.

2.2 Before opening the package: The LEDs should be kept at 30°C or less and 90%RH or less.

2.3 After opening the package: The LED's floor life are 72 hours under 30°C or less and 60% RH or less. If unused LEDs remain, it should be stored in moisture proof packages.

2.4 If the moisture absorbent material (silica gel) has faded away or the LEDs have exceeded the storage time, baking treatment should be performed using the following conditions. Baking treatment : 60±5°C for 24 hours.

3. Soldering Condition

3.1 Pb-free solder temperature profile

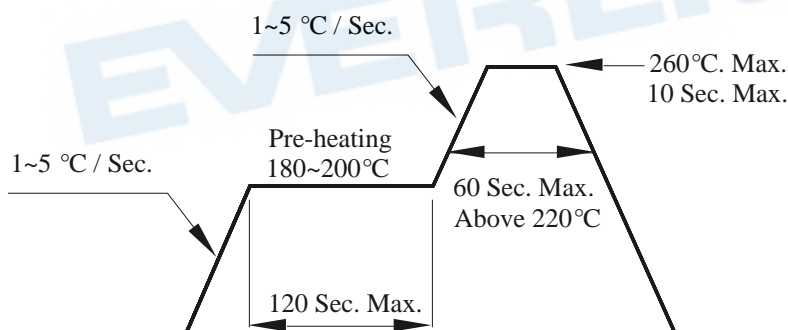

3.2 Reflow soldering should not be done more than two times.

3.3 When soldering, do not put stress on the LEDs during heating.

3.4 After soldering, do not warp the circuit board.

Technical Data Sheet

Power Top View LEDs

67-31E/T2C-VW1X2MZ3/2T

4.Soldering Iron

Each terminal is to go to the tip of soldering iron temperature less than 350°C for 3 seconds within once in less than the soldering iron capacity 25W. Leave two seconds and more intervals, and do soldering of each terminal. Be careful because the damage of the product is often started at the time of the hand solder.

5.Repairing

Repair should not be done after the LEDs have been soldered. When repairing is unavoidable, a double-head soldering iron should be used (as below figure). It should be confirmed beforehand whether the characteristics of the LEDs will or will not be damaged by repairing.

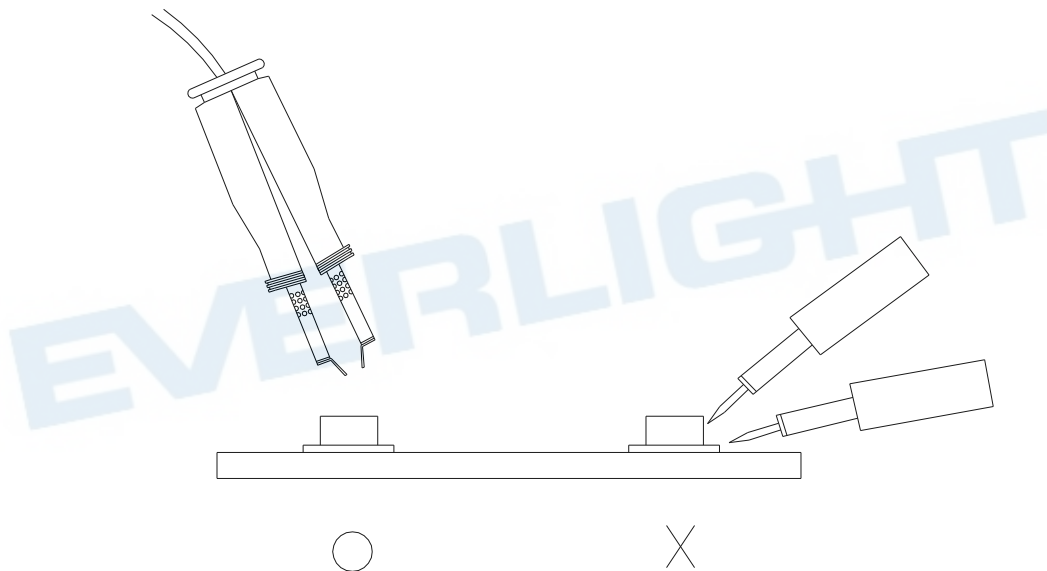

Technical Data Sheet
Power Top View LEDs

67-31E/T2C-VW1X2MZ3/2T

DISCLAIMER

1. EVERLIGHT reserves the right(s) on the adjustment of product material mix for the specification.
2. The product meets EVERLIGHT published specification for a period of twelve (12) months from date of shipment.
3. The graphs shown in this datasheet are representing typical data only and do not show guaranteed values.
4. When using this product, please observe the absolute maximum ratings and the instructions for using outlined in these specification sheets. EVERLIGHT assumes no responsibility for any damage resulting from the use of the product which does not comply with the absolute maximum ratings and the instructions included in these specification sheets.
5. These specification sheets include materials protected under copyright of EVERLIGHT. Reproduction in any form is prohibited without obtaining EVERLIGHT's prior consent.
6. This product is not intended to be used for military, aircraft, automotive, medical, life sustaining or life saving applications or any other application which can result in human injury or death. Please contact authorized Everlight sales agent for special application request.

EVERLIGHT ELECTRONICS CO., LTD.
Office: No 25, Lane 76, Sec 3, Chung Yang Rd,
Tucheng, Taipei 236, Taiwan, R.O.C

Tel: 886-2-2267-2000, 2267-9936
Fax: 886-2267-6244, 2267-6189, 2267-6306
<http://www.everlight.com>