

## SMD ■ MID POWER LED

62-217D/KK5D-3MXXXXXXXXX2530U6/2T/EU

**Features**

- PLCC-2 Package
- Top view white LED
- High luminous flux output
- High current capability
- High Efficiency
- Wide viewing angle
- Pb-free
- RoHS compliant
- ANSI Binning

**Description**

The Everlight 0.2W 62-217D package has high efficacy, high CRI, low power consumption, wide viewing angle and a compact form factor. These features make this package an ideal LED for all lighting application.

**Applications**

- Decorative and Entertainment Lighting
- Light pipe application
- Indicator and backlight in office and family equipment
- General use

**Product Number Explanation**

**62-217D / KK 5 D – 3M XX XX XX XX XXXXU6/ 2T/EU**

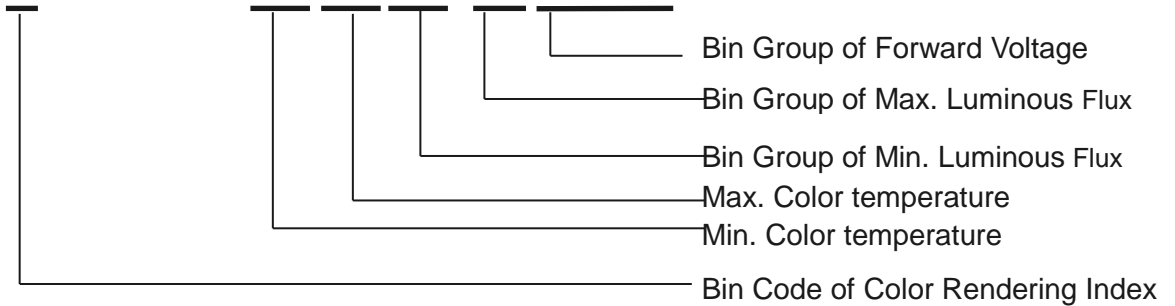

**Table of Color Rendering Index**

Symbol	Description
M	CRI(Min.) : 60
N	CRI(Min.) : 65
L	CRI(Min.) : 70
Q	CRI(Min.) : 75
K	CRI(Min.) : 80
H	CRI(Min.) : 90

Note:  
 Tolerance of Color Rendering Index: ±3

Example:

62-217D/KK5D-3M4040X2Y22530U6/2T/EU

CRI	80(Min.)
CCT	4000K
Flux	32~42lm
V <sub>F</sub>	2.5~3.0V
I <sub>F</sub>	65mA

Mass Production List for CRI>80

Product	CRI Min.(1)	CCT(K)	Φ(lm) Min. (2)	Φ(lm) Typ. (2)	Φ(lm) Max. (2)
62-217D/KK5D-3M2727X0Y02530U6/2T/EU	80	2700K	30	31	40
62-217D/KK5D-3M3030X1Y12530U6/2T/EU	80	3000K	31	32	41
62-217D/KK5D-3M3535X1Y12530U6/2T/EU	80	3500K	31	32	41
62-217D/KK5D-3M4040X2Y22530U6/2T/EU	80	4000K	32	33	42
62-217D/KK5D-3M5050X3Y32530U6/2T/EU	80	5000K	33	34	43
62-217D/KK5D-3M5757X3Y32530U6/2T/EU	80	5700K	33	34	43
62-217D/KK5D-3M6565X2Y22530U6/2T/EU	80	6500K	32	33	42

Note:

1. Tolerance of Color Rendering Index:  $\pm 3$
2. Tolerance of Luminous flux:  $\pm 11\%$ .

EVERLIGHT

## Device Selection Guide

Chip Materials	Emitted Color	Resin Color
InGaN	Cool White	Water Clear
	Neutral White	
	Warm White	

## Absolute Maximum Ratings (T<sub>Soldering</sub>=25°C)

Parameter	Symbol	Rating	Unit
Forward Current	I <sub>F</sub>	180	mA
Peak Forward Current (Duty 1/10 @10ms)	I <sub>FP</sub>	300	mA
Power Dissipation	P <sub>d</sub>	540	mW
Operating Temperature	T <sub>opr</sub>	-40 ~ +85	°C
Storage Temperature	T <sub>stg</sub>	-40 ~ +100	°C
Thermal Resistance (Junction / Soldering point)	R <sub>th J-S</sub>	21	°C/W
Junction Temperature	T <sub>j</sub>	115	°C
Soldering Temperature	T <sub>sol</sub>	Reflow Soldering : 260 °C for 10 sec. Hand Soldering : 350 °C for 3 sec.	

## Electro-Optical Characteristics (T<sub>Soldering</sub>=25°C)

Parameter	Symbol	Min.	Typ.	Max.	Unit	Condition
Luminous Flux <sup>(1)</sup>	Φ	30	-----	43	lm	I <sub>F</sub> =65mA
Forward Voltage <sup>(2)</sup>	V <sub>F</sub>	2.5	-----	3.0	V	I <sub>F</sub> =65mA
Color Rendering Index <sup>(3)</sup>	R <sub>a</sub>	80	-----	-----	-----	I <sub>F</sub> =65mA
Viewing Angle	2θ <sub>1/2</sub>	-----	120	-----	deg	I <sub>F</sub> =65mA
Reverse Current	I <sub>R</sub>	-----	-----	1.5	μA	V <sub>R</sub> =5V

Notes:

1. Tolerance of Luminous flux: ±11%.
2. Tolerance of Forward Voltage: ±0.1V.
3. Tolerance of Color Rendering Index: ±3

**Bin Range of Luminous Flux**

**2700K----62-217D/KK5D-3M2727X0Y02530U6/2T/EU**

Bin Code	Min.	Max.	Unit	Condition
T1	30	32	lm	I <sub>F</sub> =65mA
T2	32	34		
T3	34	36		
T4	36	38		
T5	38	40		

**3000K----62-217D/KK5D-3M3030X1Y12530U6/2T/EU**

Bin Code	Min.	Max.	Unit	Condition
T1	31	33	lm	I <sub>F</sub> =65mA
T2	33	35		
T3	35	37		
T4	37	39		
T5	39	41		

**3500K----62-217D/KK5D-3M3535X1Y12530U6/2T/EU**

Bin Code	Min.	Max.	Unit	Condition
T1	31	33	lm	I <sub>F</sub> =65mA
T2	33	35		
T3	35	37		
T4	37	39		
T5	39	41		

**4000K----62-217D/KK5D-3M4040X2Y22530U6/2T/EU**

Bin Code	Min.	Max.	Unit	Condition
T1	32	34	lm	I <sub>F</sub> =65mA
T2	34	36		
T3	36	38		
T4	38	40		
T5	40	42		

**5000K----62-217D/KK5D-3M5050X3Y32530U6/2T/EU**

Bin Code	Min.	Max.	Unit	Condition
T1	33	35	lm	I <sub>F</sub> =65mA
T2	35	37		
T3	37	39		
T4	39	41		
T5	41	43		

**5700K----62-217D/KK5D-3M5757X3Y32530U6/2T/EU**

Bin Code	Min.	Max.	Unit	Condition
T1	33	35	lm	I <sub>F</sub> =65mA
T2	35	37		
T3	37	39		
T4	39	41		
T5	41	43		

**6500K----62-217D/KK5D-3M6565X2Y22530U6/2T/EU**

Bin Code	Min.	Max.	Unit	Condition
T1	32	34	lm	I <sub>F</sub> =65mA
T2	34	36		
T3	36	38		
T4	38	40		
T5	40	42		

Notes:  
Tolerance of Luminous flux: ±11%

**Bin Range of Forward Voltage**

Group	Bin Code	Min.	Max.	Unit	Condition
2530	32	2.5	2.6	V	I <sub>F</sub> =65mA
	33	2.6	2.7		
	34	2.7	2.8		
	35	2.8	2.9		
	36	2.9	3.0		

**Bin Code of Macadam 3 step**

Step	CCT	Cx	Cy	a	b	theta
3	2700	0.4583	0.4104	0.00810	0.00420	49.70
	3000	0.4345	0.4033	0.00834	0.00408	50.22
	3500	0.4080	0.3919	0.00927	0.00414	51.00
	4000	0.3827	0.3803	0.00939	0.00402	54.80
	5000	0.3451	0.3559	0.00822	0.00354	64.12
	5700	0.3293	0.3423	0.00747	0.00321	66.51
	6500	0.3131	0.3290	0.00669	0.00285	64.57

**The C.I.E. 1931 Chromaticity Diagram**

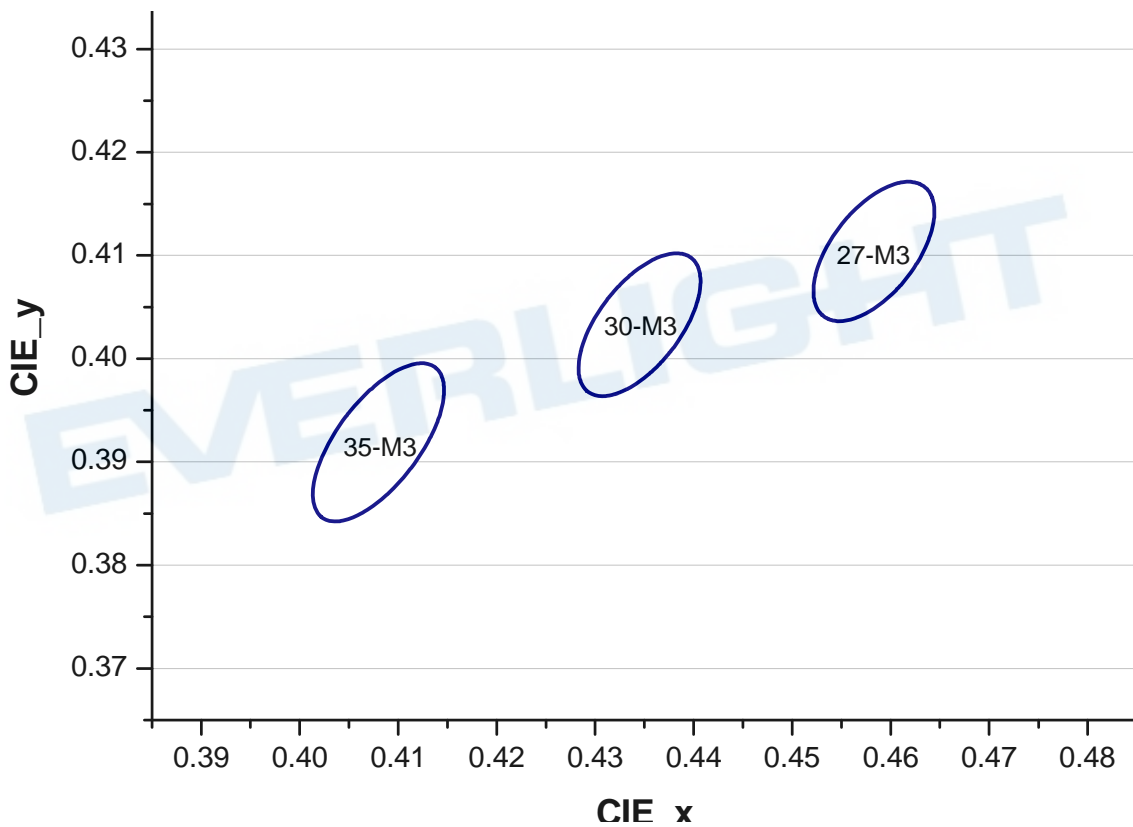

### The C.I.E. 1931 Chromaticity Diagram

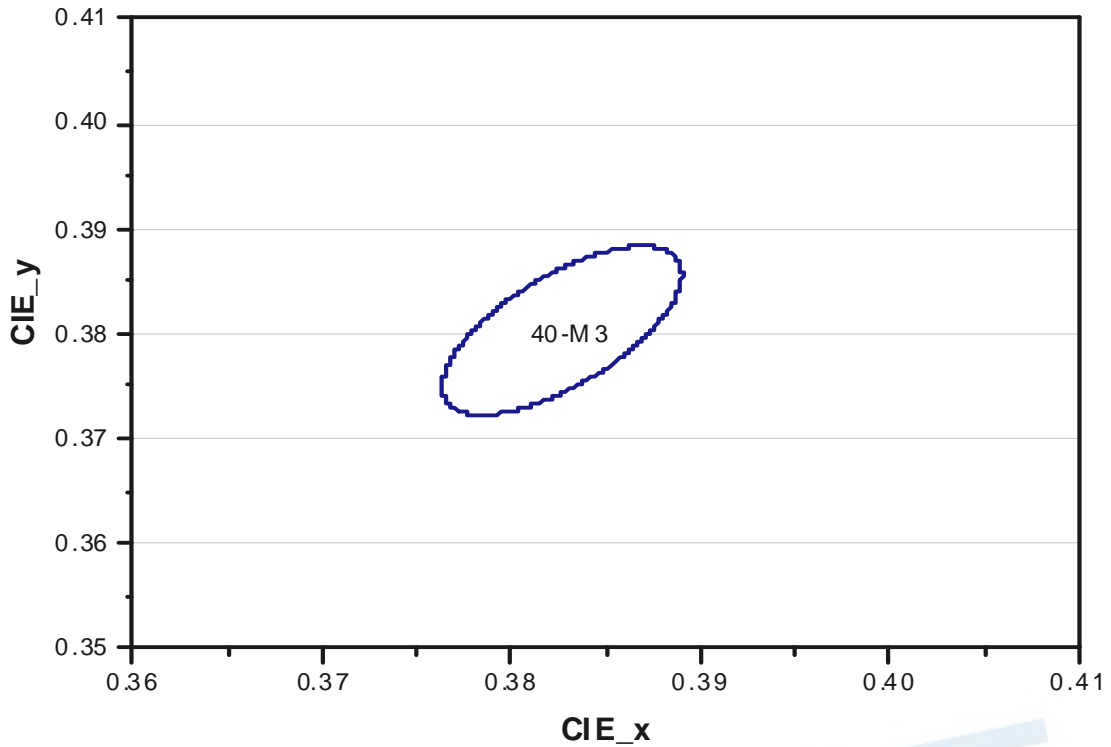

### The C.I.E. 1931 Chromaticity Diagram

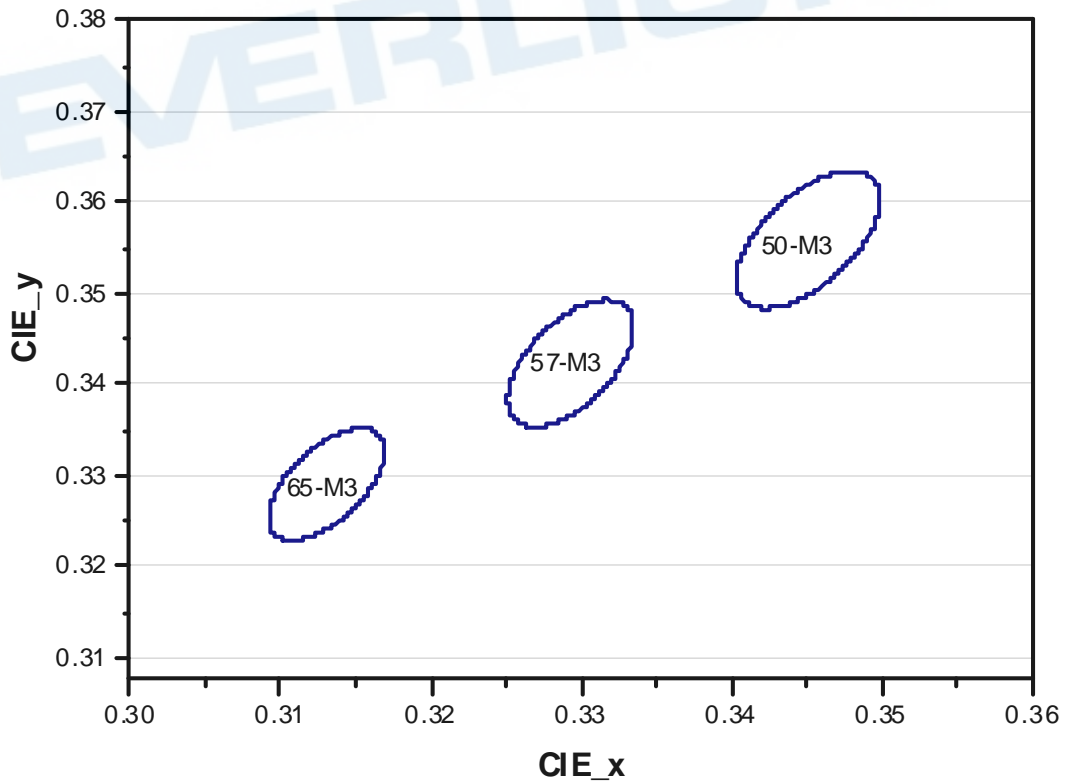

Note:

1. The value is based on driving current by 65mA.
2. Tolerance of Chromaticity Coordinates:  $\pm 0.01$ .

**Spectrum Distribution**

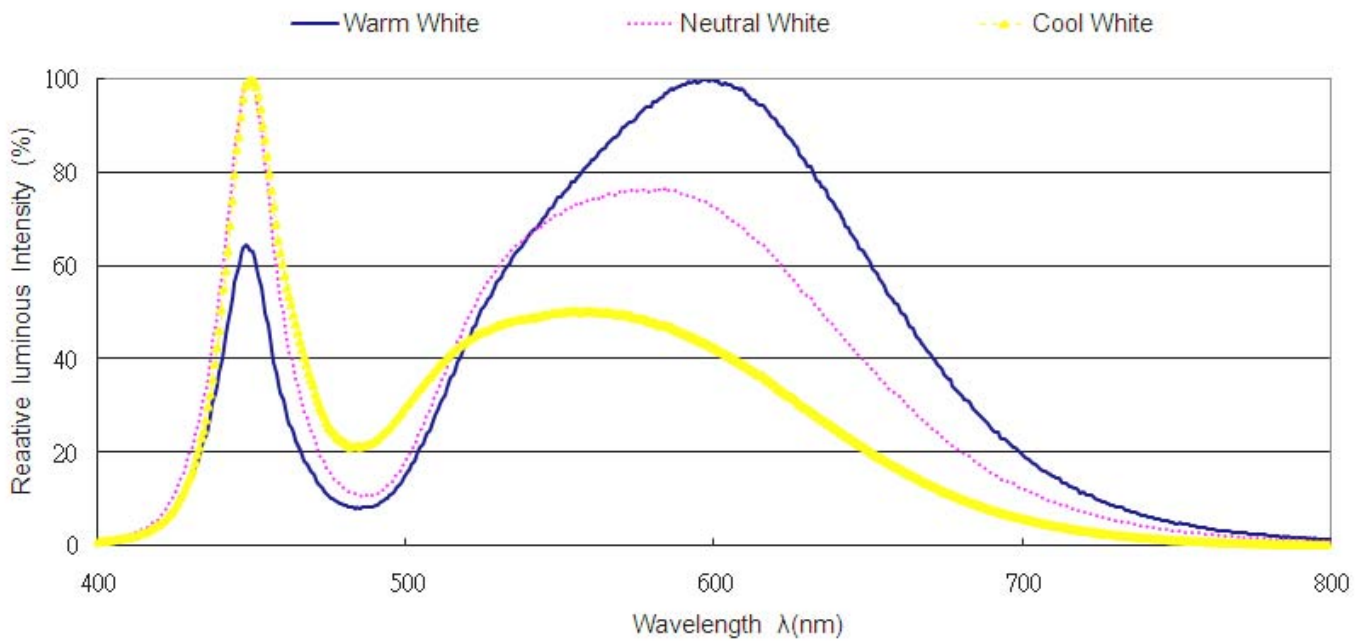

**Typical Electro-Optical Characteristics Curves**

**Fig.1 – Forward Voltage Shift vs. Junction Temperature**

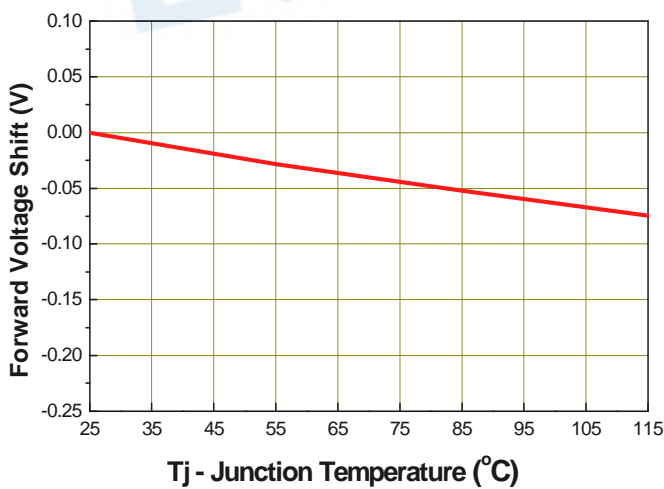

**Fig.2 - Relative Luminous Intensity vs. Forward Current**

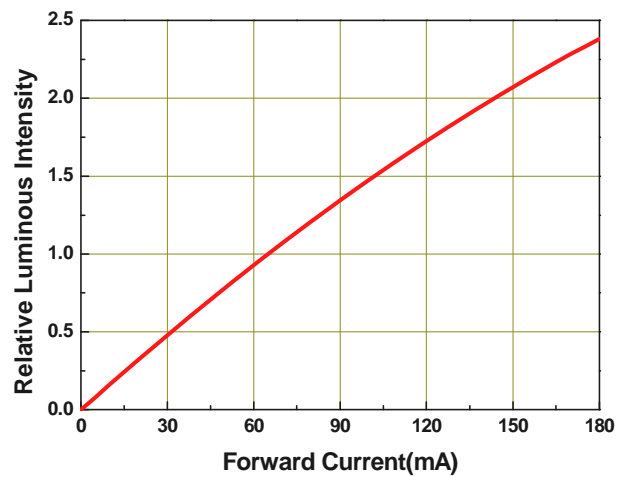

Typical Electro-Optical Characteristics Curves

Fig.3 - Relative Luminous Intensity vs. Junction Temperature

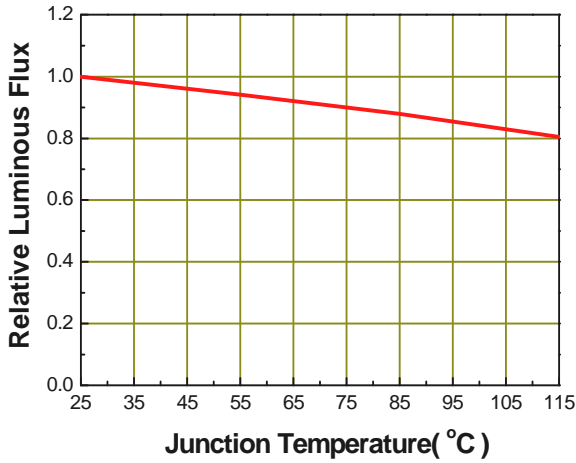

Fig.4 - Forward Current vs. Forward Voltage

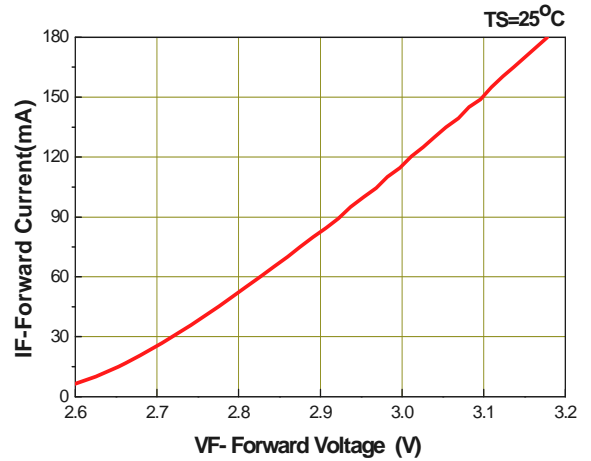

Fig.5 – Max. Driving Forward Current vs. Soldering Temperature

$R_{th\ j-s}=21\ ^\circ\text{C/W}$

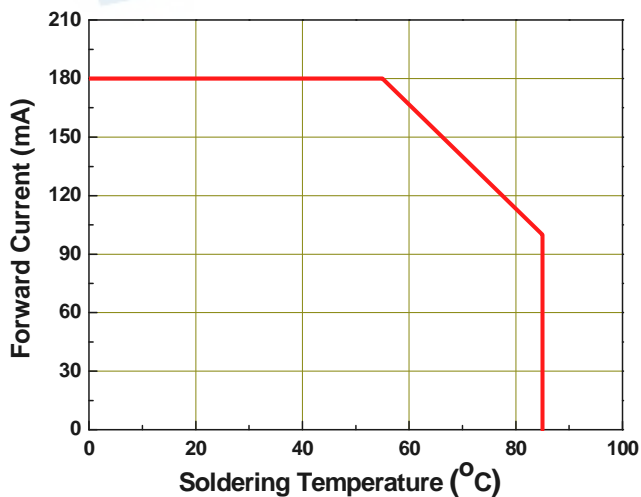
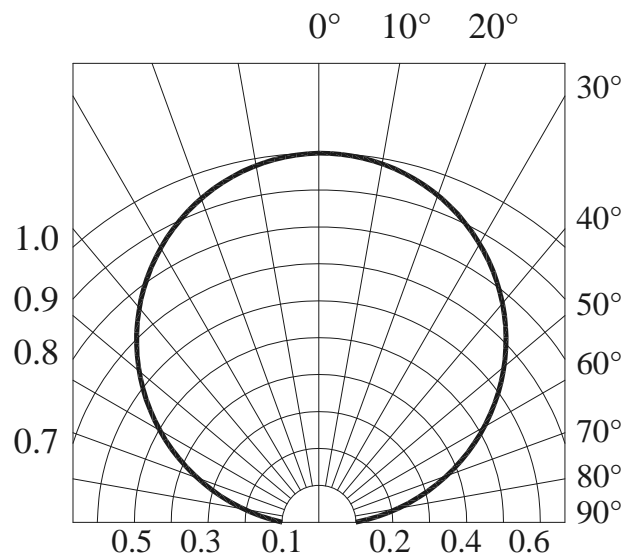
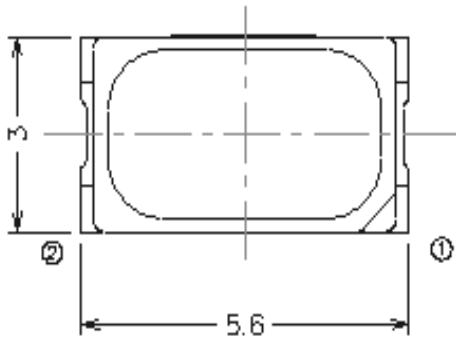

Fig.6 – Radiation Diagram



Package Dimension



Polarity

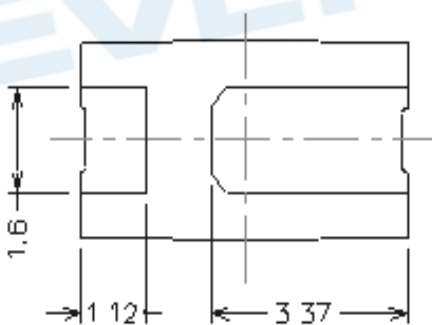

Bot view

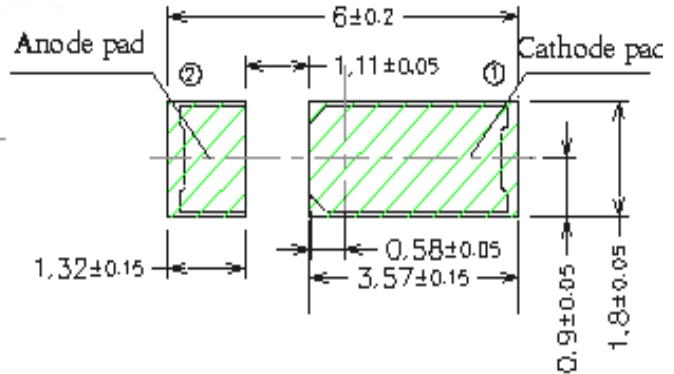

Soldering patterns

Note:

Tolerance unless mentioned is  $\pm 0.1\text{mm}$ ; Unit = mm

**Moisture Resistant Packing Materials**

**Label Explanation**

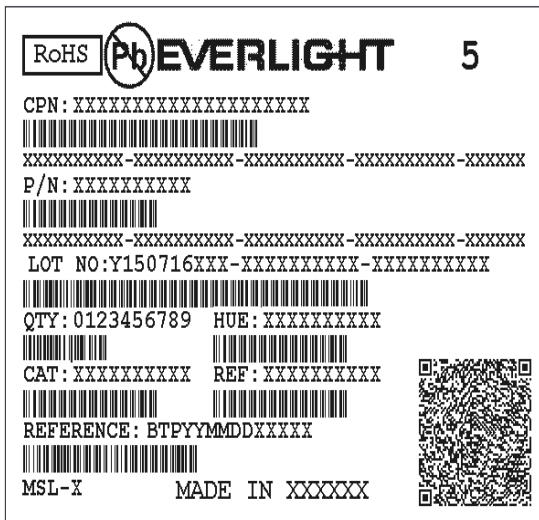

- CPN: Customer's Product Number
- P/N: Product Number
- QTY: Packing Quantity
- CAT: Luminous Intensity Rank
- HUE: Dom. Wavelength Rank
- REF: Forward Voltage Rank
- LOT No: Lot Number

**Reel Dimensions**

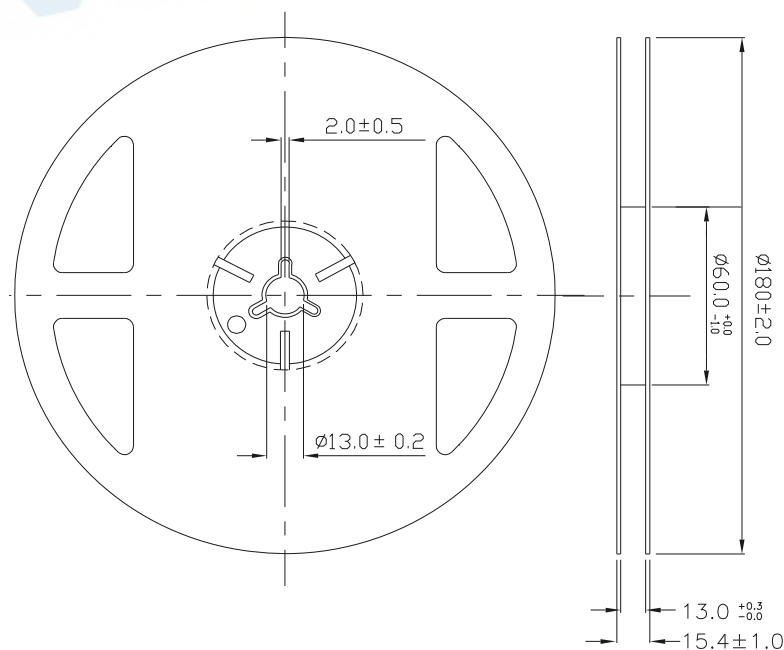

Note:  
 Tolerances unless mentioned  $\pm 0.1$ mm. Unit = mm

**Carrier Tape Dimensions: Loaded Quantity 2000 pcs. Per Reel**

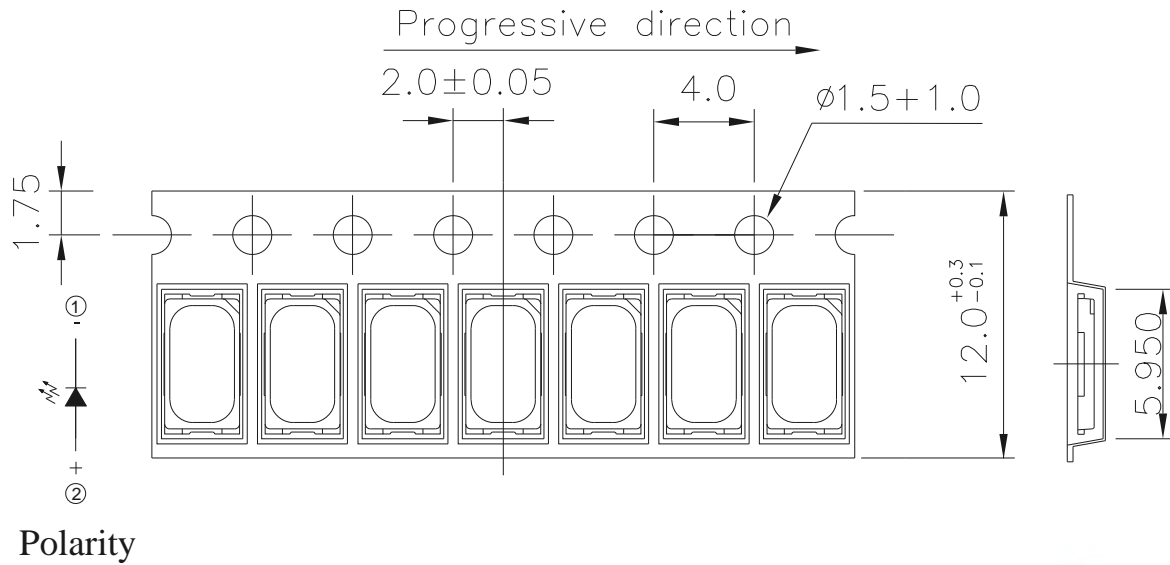

Note:  
Tolerance unless mentioned is  $\pm 0.1$  mm; Unit = mm

**Moisture Resistant Packing Process**

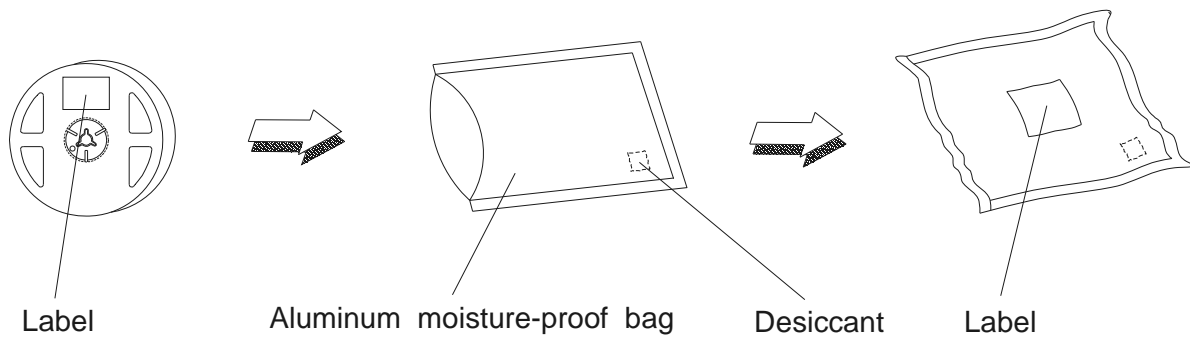

## Reliability Test Items and Conditions

The reliability of products shall be satisfied with items listed below.  
 Confidence level : 90%  
 LTPD : 10%

No.	Items	Test Condition	Test Hours/Cycles	Sample Size	Ac/Re
1	Resistance to Solder Heat	Temp. : 260°C/10sec.	3 Times.	8 PCS.	0/1
2	Temperature Cycle	-40°C~100°C / Dwell time 30min	200 Cycles	8 PCS.	0/1
3	High Temperature/Humidity Life	Ta=85°C,85%RH, I <sub>F</sub> = 180mA	1000 Hrs.	8 PCS.	0/1
4	Low Temperature Life	Ta=-40°C, I <sub>F</sub> = 180 mA	1000 Hrs.	8 PCS.	0/1
5	High Temperature Life	Ta=60°C, I <sub>F</sub> =180 mA	3000 Hrs.	8 PCS.	0/1
6	High Temperature Life	Ta=85°C, I <sub>F</sub> =180 mA	3000 Hrs.	8 PCS.	0/1
7	Pulse	ON 30ms / OFF 2500ms	30000 CYCLES	8 PCS.	0/1
8	Thermal Shock	H : +100°C 20min ∩ 10 sec L : -40°C 20min	200 Cycles	8 PCS.	0/1
9	Power Temperature Cycle	H : +100°C 15min ∩ 5 min L : -40°C 15min I <sub>F</sub> = 120 mA	200 Cycles	8 PCS.	0/1

## Precautions for Use

1. Over-current-proof

Customer must apply resistors for protection; otherwise slight voltage shift will cause big current change (Burn out will happen).

2. Storage

2.1 Do not open moisture proof bag before the products are ready to use.

2.2 Before opening the package: The LEDs should be kept at 30°C or less and 90%RH or less.

2.3 After opening the package: The LED's floor life is 168 Hrs under 30°C or less and 60% RH or less. If unused LEDs remain, it should be stored in moisture proof packages.

2.4 If the moisture absorbent material (silica gel) has faded away or the LEDs have exceeded the storage time, baking treatment should be performed using the following conditions.

Baking treatment: 60±5°C for 24 hours.

3. Soldering Condition

3.1 Pb-free solder temperature profile

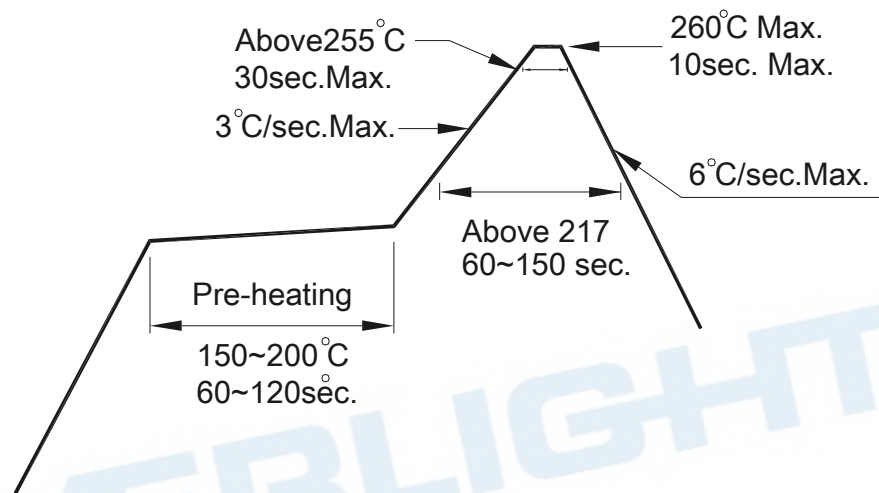

3.2 Reflow soldering should not be done more than two times.

3.3 When soldering, do not put stress on the LEDs during heating.

3.4 After soldering, do not warp the circuit board.

4. Soldering Iron

Each terminal is to go to the tip of soldering iron temperature less than 350°C for 3 seconds within once in less than the soldering iron capacity 25W. Leave two seconds and more intervals, and do soldering of each terminal. Be careful because the damage of the product is often started at the time of the hand solder.

5. Repairing

Repair should not be done after the LEDs have been soldered. When repairing is unavoidable, a double-head soldering iron should be used (as below figure). It should be confirmed beforehand whether the characteristics of the LEDs will or will not be damaged by repairing.

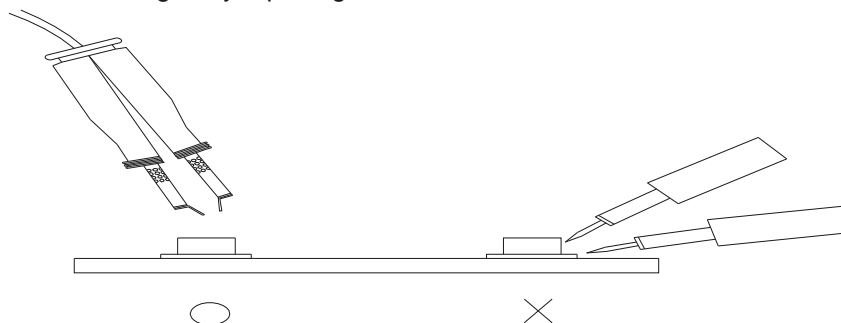

DISCLAIMER

1. EVERLIGHT reserves the right(s) on the adjustment of product material mix for the specification.
2. The product meets EVERLIGHT published specification for a period of twelve (12) months from date of shipment.
3. The graphs shown in this datasheet are representing typical data only and do not show guaranteed values.
4. When using this product, please observe the absolute maximum ratings and the instructions for using outlined in these specification sheets. EVERLIGHT assumes no responsibility for any damage resulting from the use of the product which does not comply with the absolute maximum ratings and the instructions included in these specification sheets.
5. These specification sheets include materials protected under copyright of EVERLIGHT. Reproduction in any form is prohibited without obtaining EVERLIGHT's prior consent.
6. This product is not intended to be used for military, aircraft, automotive, medical,