

Top View LEDs

61-238/GBRSB7C-B05/ET



Features

- Super-luminosity chip LED.
- White SMT package.
- Built in Red, Green, and Blue chips.
- Lead frame package with individual 6 pins.
- Wide viewing angle.
- Soldering methods: IR reflow soldering.
- Pb-free.
- The product itself will remain within RoHS compliant version.
- Compliance with EU REACH.
- Compliance Halogen Free .(Br<900ppm,Cl<900ppm,Br+Cl<1500ppm).
- Precondition: Bases on JEDEC J-STD 020D

Descriptions

• Due to the package design, 61-238 has wide viewing angle, and low power consumption. The white LED which was fabricated using blue LEDs and a phosphor, and the phosphor is excited by blue light and emits yellow fluorescence. The mixture of blue light and yellow light results in a white emission. And makes it ideal for light pipe application.

Applications

- Amusement equipment.
- Information boards.
- Flashlight for digital camera of cellular phone.

Device Selection Guide

Group	Chip Materials	Emitted Color	Resin Color
GB	InGaN	Brilliant Green	Water Clear
RS	AlGaInP	Brilliant Red	Water Clear
B7	InGaN	Blue	Water Clear

Absolute Maximum Ratings (Ta=25°C)

Parameter	Symbol	Rating	Unit
Reverse Voltage	V_R	5	V
Forward Current	I_F	GB	30
		RS	50
		B7	30
Peak Forward Current (Duty 1/10 @1KHz)	I_{FP}	GB	100
		RS	100
		B7	100
Power Dissipation	P_d	GB	110
		RS	120
		B7	110
Junction Temperature	T_j	115	°C
Operating Temperature	T_{opr}	-40 ~ +85	°C
Storage Temperature	T_{stg}	-40 ~ +90	°C
ESD	ESD	1000	V
Soldering Temperature	T_{sol}	Reflow Soldering : 260 °C for 10 sec. Hand Soldering : 350 °C for 3 sec.	

Electro-Optical Characteristics (Ta=25°C)

Parameter	Symbol	Code	Min.	Typ.	Max.	Unit	Condition
Luminous Intensity	I _v	GB	900	-----	1800	mcd	I _F =20mA
		RS	450	-----	900		
		B7	225	-----	450		
Viewing Angle	2θ _{1/2}		---	120	---	deg	I _F =20mA
Peak Wavelength	λ _p	GB	---	518	---	nm	I _F =20mA
		RS	---	632	---		
		B7	---	468	---		
Dominant Wavelength	λ _d	GB	525	-----	535	nm	I _F =20mA
		RS	617.5	-----	629.5		
		B7	465	-----	475		
Spectrum Radiation Bandwidth	Δλ	GB	---	35	---	nm	I _F =20mA
		RS	---	20	---		
		B7	---	25	---		
Forward Voltage	V _F	GB	2.75	-----	3.65	V	I _F =20mA
		RS	1.75	-----	2.55		
		B7	2.75	-----	3.65		
Reverse Current	I _R	GB	---	---	50	μA	V _R =5V
		RS	---	---	10	μA	
		B7	---	---	50	μA	

Notes:

1. Tolerance of Luminous Intensity: ±11%
2. Tolerance of Dominant Wavelength: ±1 nm
3. Tolerance of Forward Voltage: ±0.1V

Bin Range of Luminous Intensity

Chip	Bin Code	Min.	Max.	Unit	Condition
GB	V2	900	1120	mcd	I _F =20mA
	W1	1120	1420		
	W2	1420	1800		
RS	U1	450	565		
	U2	565	715		
	V1	715	900		
B7	S2	225	285		
	T1	285	360		
	T2	360	450		

Note:
Tolerance of Luminous Intensity: ±11%

Bin Range of Dominant Wavelength

Chip	Bin Code	Min.	Max.	Unit	Condition
GB	Y	525	530	nm	I _F =20mA
	Z	530	535		
RS	E4	617.5	621.5		
	E5	621.5	625.5		
	E6	625.5	629.5		
B7	X	465	470		
	Y	470	475		

Note:
Tolerance of Luminous Intensity: ±11%

Bin Range of Forward Voltage

Chip	Bin Code	Min.	Max.	Unit	Condition
GB	5	2.75	3.05	V	I _F =20mA
	6	3.05	3.35		
	7	3.35	3.65		
RS	0	1.75	1.95		
	1	1.95	2.15		
	2	2.15	2.35		
B7	3	2.35	2.55		
	5	2.75	3.05		
	6	3.05	3.35		
	7	3.35	3.65		

Note:
Tolerance of Forward Voltage: ±0.1V

Typical Electro-Optical Characteristics Curves (GB)

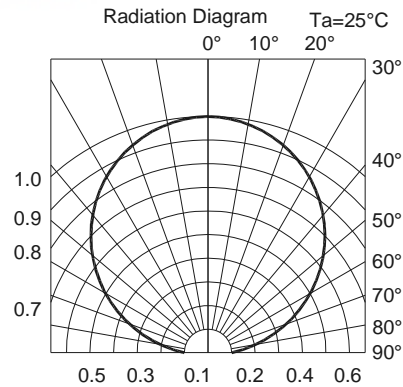
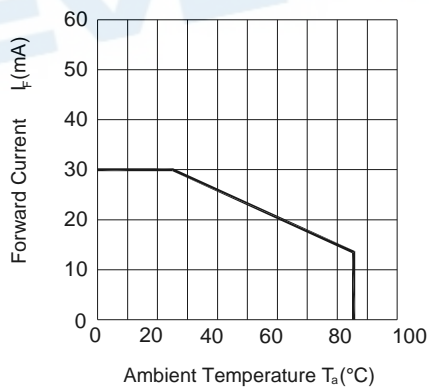
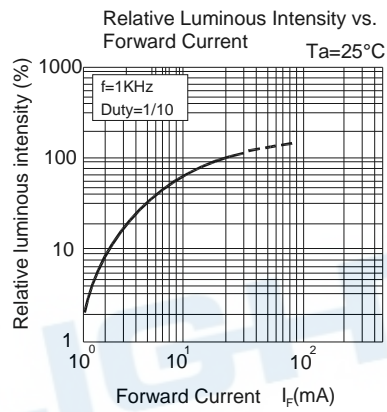
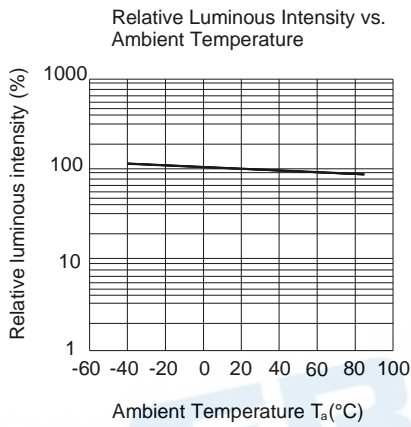
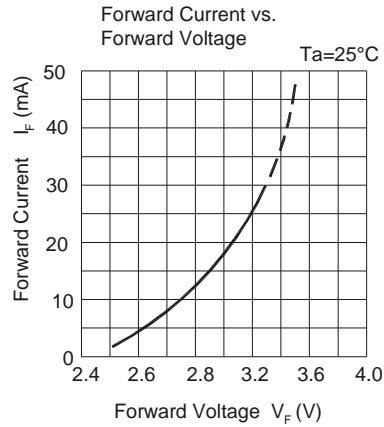
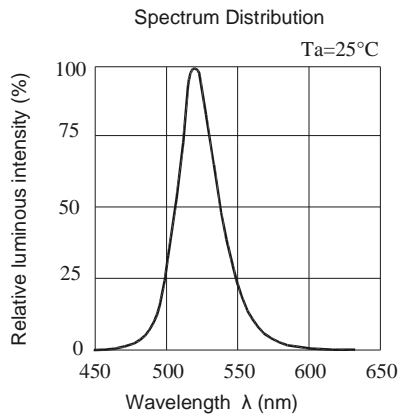

Typical Electro-Optical Characteristics Curves (RS)

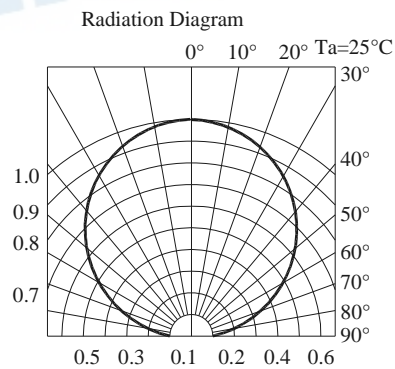
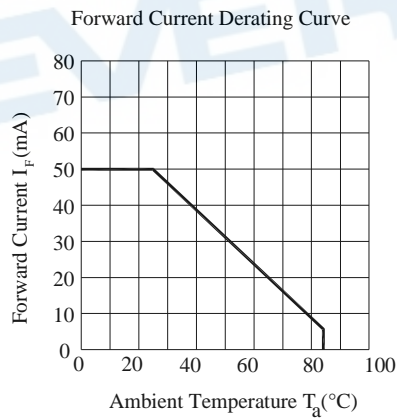
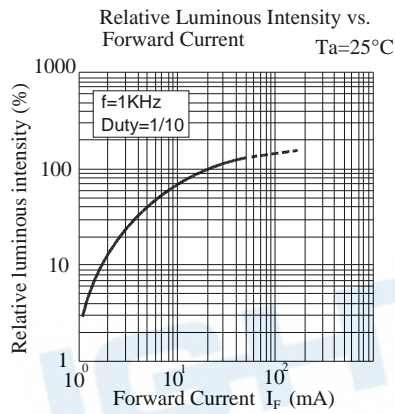
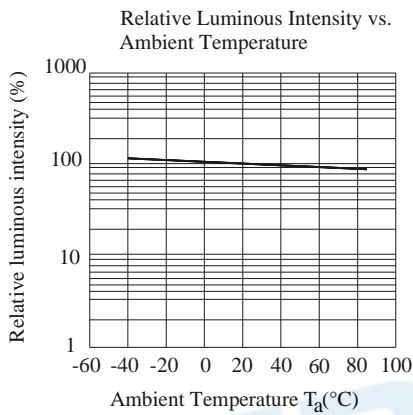
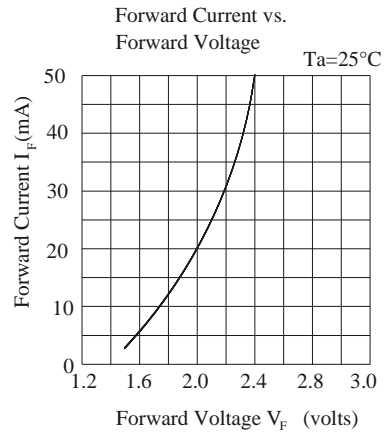
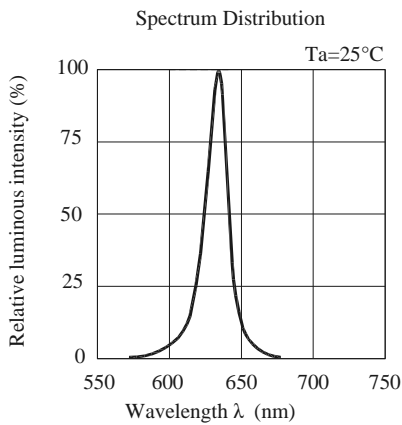

Typical Electro-Optical Characteristics Curves (B7)

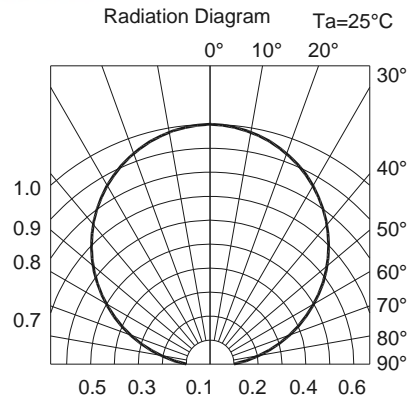
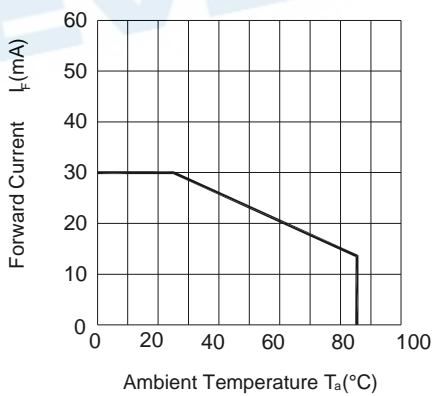
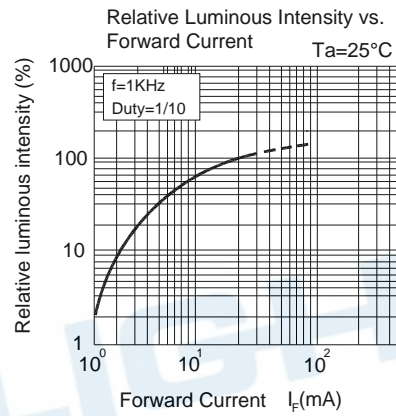
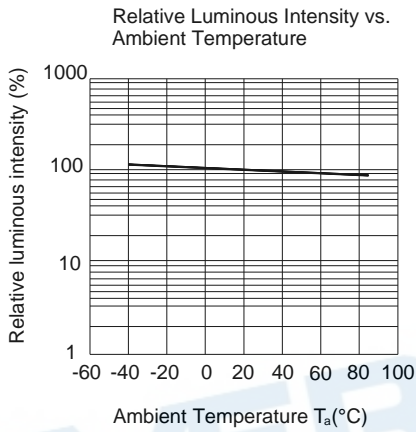
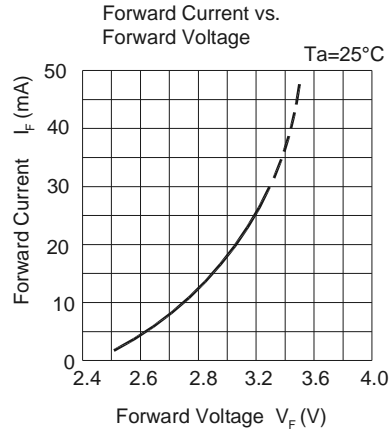
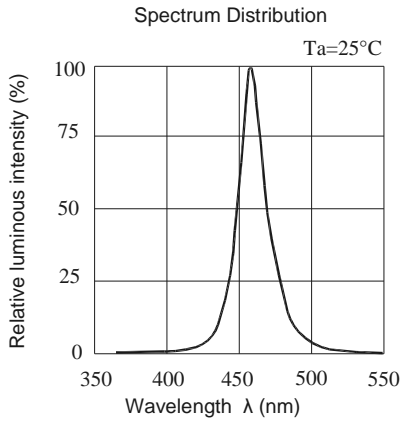

Package Dimension

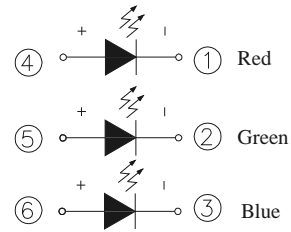
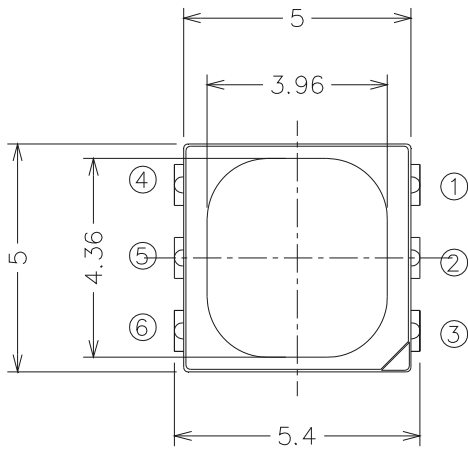

Polarity

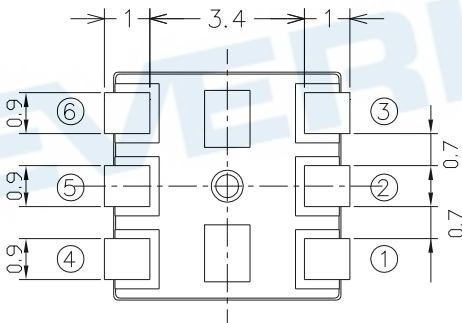
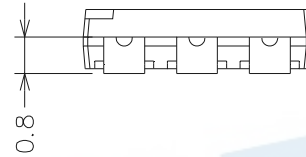
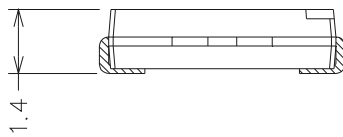

Bot. view

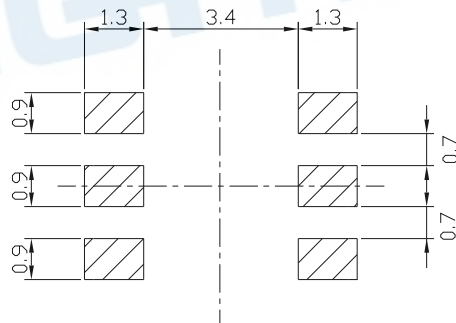

Soldering patterns

Note: Tolerances unless mentioned ± 0.1 mm. Unit = mm

Moisture Resistant Packing Materials

Label Explanation

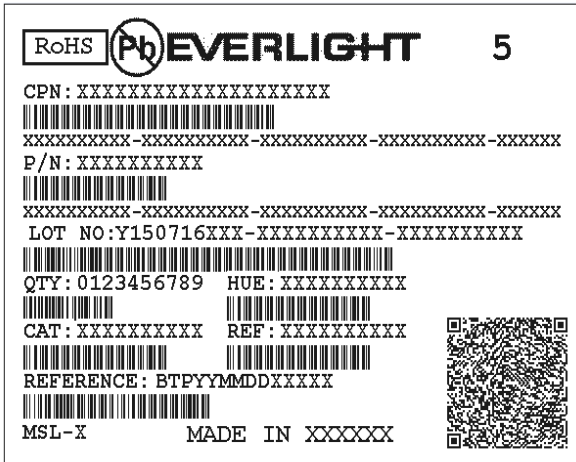

- CPN: Customer's Product Number
- P/N: Product Number
- QTY: Packing Quantity
- CAT: Luminous Intensity Rank
- HUE: Dom. Wavelength Rank
- REF: Forward Voltage Rank
- LOT No: Lot Number

Reel Dimensions

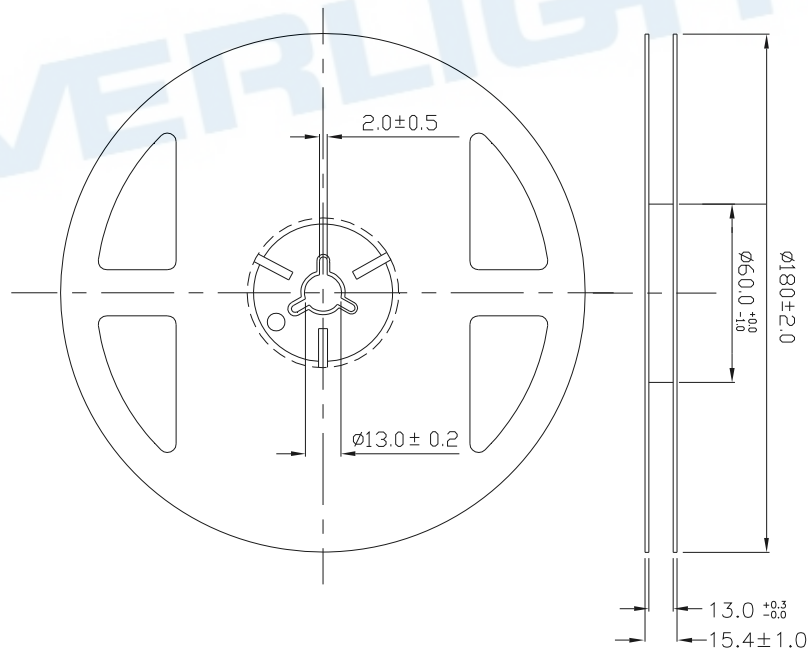

Note:
 Tolerances unless mentioned ± 0.1 mm. Unit = mm

Carrier Tape Dimensions: Loaded Quantity 800 pcs Per Reel

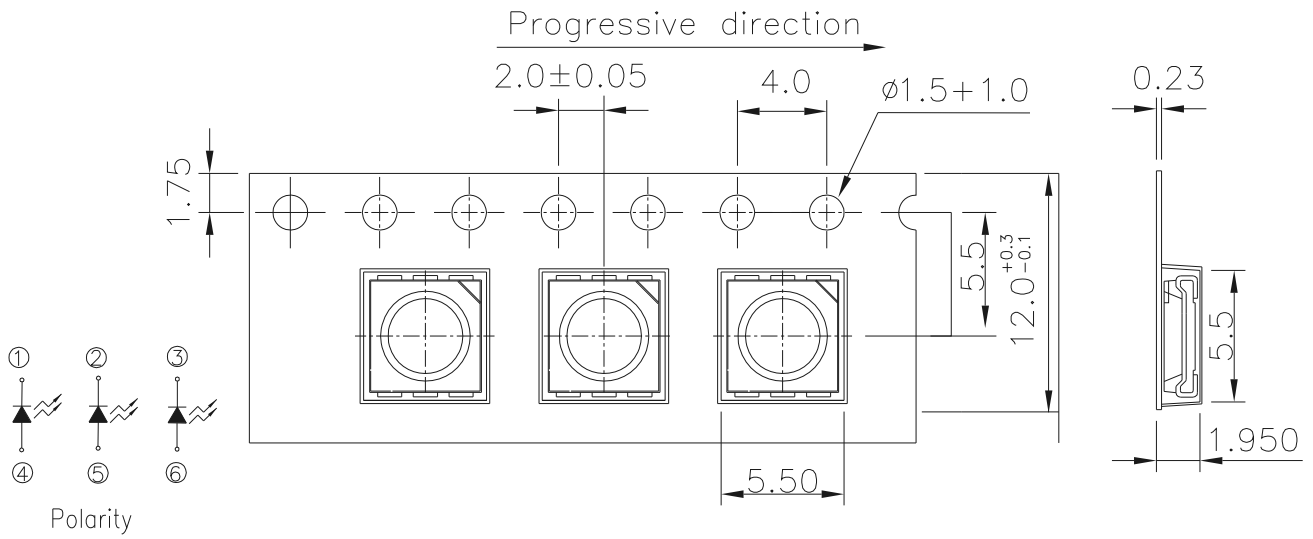

Notes:

1. Tolerances unless mentioned ±0.1mm. Unit = mm
2. Amount less than 800pcs can accept in bulk packing .

Moisture Resistant Packing Process

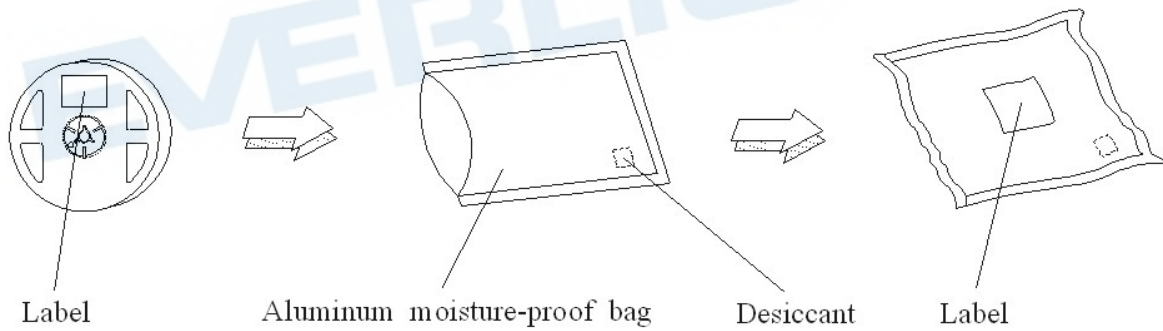

Precautions for Use

1. Over-current-proof

1.1 Customer must apply resistors for protection, otherwise slight voltage shift will cause big current change (Burn out will happen).

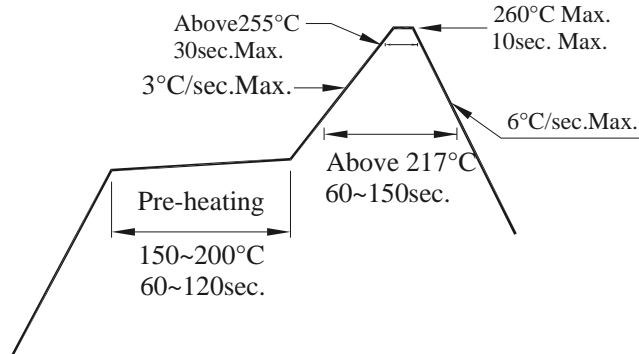

2. Storage

2.1 Moisture proof bag should only be opened immediately prior to usage.

2.2 Environment should be less than 30°C and 60% RH when moisture proof bag is opened.

2.3 After opening the package MSL Conditions stated on page 1 of this spec should not be exceeded.

2.4 If the moisture sensitivity card indicates higher than acceptable moisture, the component should be baked at min. 60deg +/-5deg for 24 hours.

3. Soldering Condition

3.1 Pb-free solder temperature profile

3.2 Reflow soldering should not be done more than two times.

3.3 When soldering, do not put stress on the LEDs during heating.

3.4 After soldering, do not warp the circuit board.

4. Soldering Iron

Each terminal is to go to the tip of soldering iron temperature less than 350°C for 3 seconds within once in less than the soldering iron capacity 25W. Leave two seconds and more intervals, and do soldering of each terminal. Be careful because the damage of the product is often started at the time of the hand solder.

5. Repairing

Repair should not be done after the LEDs have been soldered. When repairing is unavoidable, a double-head soldering iron should be used (as below figure). It should be confirmed beforehand whether the characteristics of the LEDs will or will not be damaged by repairing.

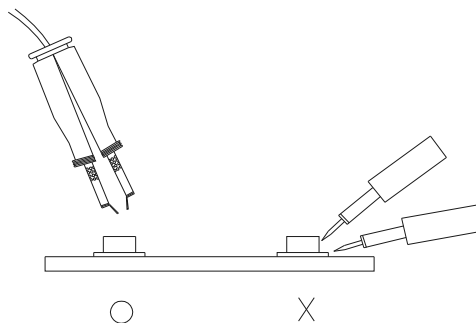

Application Restrictions

High reliability applications such as military/aerospace, automotive safety/security systems, and medical equipment may require different product. If you have any concerns, please contact Everlight before using this product in your application. This specification guarantees the quality and performance of the product as an individual component. Do not use this product beyond the specification described in this document.

DISCLAIMER

1. EVERLIGHT reserves the right(s) on the adjustment of product material mix for the specification.
2. The product meets EVERLIGHT published specification for a period of twelve (12) months from date of shipment.
3. The graphs shown in this datasheet are representing typical data only and do not show guaranteed values.
4. When using this product, please observe the absolute maximum ratings and the instructions for using outlined in these specification sheets. EVERLIGHT assumes no responsibility for any damage resulting from the use of the product which does not comply with the absolute maximum ratings and the instructions included in these specification sheets.
5. These specification sheets include materials protected under copyright of EVERLIGHT. Reproduction in any form is prohibited without obtaining EVERLIGHT's prior consent.
6. This product is not intended to be used for military, aircraft, automotive, medical, life sustaining or life saving applications or any other application which can result in human injury or death. Please contact authorized Everlight sales agent for special application request.