

EL SIDE VIEW LED 57-11-UB0200H-AM



Features

- Package : PLCC 2 package
- Color : Blue
- Typ. Luminance Intensity : 355 mcd @ 20mA
- Viewing angle : 120°
- ESD : 8KV
- MSL : 2
- Qualified AEC-Q101
- The product itself will remain within RoHS compliant version
- Compliance with RoHS and REACH
- Compliance Halogen Free .(Br <900 ppm ,Cl <900 ppm , Br+Cl < 1500 ppm)

Applications

- Automotive interior lighting.
- Switches.

Contents

| | |
|-----------------------------------|----|
| 1. Characteristics | 3 |
| 2. Absolute Maximum Ratings | 4 |
| 3. Characteristics Graph | 5 |
| 4. Binning Information | 10 |
| 5. Part Number | 13 |
| 6. Ordering Information..... | 14 |
| 7. Mechanical Dimension..... | 15 |
| 8. Recommended Soldering Pad..... | 16 |
| 9. Reflow Soldering Profile..... | 16 |
| 10. Packaging Information..... | 17 |
| 11. Precaution for Use | 19 |

EVERLIGHT

1. Characteristics

| Parameter | Symbol | Min. | Typ. | Max. | Unit | Condition | |
|--|-------------|------------------|------|------|------|-------------------|-------------------|
| Forward Current | I_F | 2 | 20 | 30 | mA | --- | |
| Luminous Intensity | I_V | 224 | 355 | 560 | mcd | $I_F=20\text{mA}$ | |
| Forward Voltage | V_F | 2.75 | 3.10 | 3.75 | V | $I_F=20\text{mA}$ | |
| Viewing Angle | ϕ | --- | 120 | --- | deg | $I_F=20\text{mA}$ | |
| Dominant Wavelength | λ_d | 463 | 468 | 475 | nm | $I_F=20\text{mA}$ | |
| Thermal Resistance (Junction to Solder) | Real | $R_{th JS real}$ | --- | --- | 180 | K/W | $I_F=20\text{mA}$ |
| | Electrical | $R_{th JS el}$ | --- | --- | 140 | | |

Notes:

1. Luminous Flux measurement tolerance: $\pm 8\%$.
2. The data of Luminous Flux measured at thermal pad=25°C
3. Forward voltage measurement tolerance: $\pm 0.05\text{V}$
4. The V_F range shown in the table above indicates 99% output.
5. Tolerance of Dominant Wavelength : $\pm 1\text{nm}$.

2. Absolute Maximum Ratings

| Parameter | Symbol | Ratings | Unit |
|---|-------------|------------------------------------|------------------|
| Power Dissipation | P_d | 112 | mW |
| Forward Current | I_F | 30 | mA |
| Surge Current ($t \leq 1\text{ms}$; $D=0.005$; $T_s=25\text{ }^\circ\text{C}$) | I_{FM} | 300 | mA |
| Reverse Voltage | V_R | Not designed for reverse operation | V |
| Junction Temperature | T_J | 125 | $^\circ\text{C}$ |
| Operating Temperature | T_{opr} | -40 ~ +110 | $^\circ\text{C}$ |
| Storage Temperature | T_{stg} | -40 ~ +110 | $^\circ\text{C}$ |
| ESD Sensitivity ($R=1.5\text{k}\Omega$, $C=100\text{pF}$) | ESD_{HBM} | 8 | kV |
| Soldering Temperature | Reflow | 260 $^\circ\text{C}$ for 30sec | $^\circ\text{C}$ |

EVERLIGHT

3. Characteristics Graph

Wavelength Characteristics Relative Spectral Distribution @ Ts = 25°C, If=20mA

$$\Phi_v / \Phi_v (Max.) = f(\lambda)$$

Typical Diagram Characteristics of Radiation

$$\Phi_v / \Phi_v (0^\circ) = f(\varphi)$$

Notes:

1. φ is the off axis angle from lamp centerline where the luminous intensity is 1/2 of the peak value.
2. View angle tolerance is $\pm 5^\circ$.

Forward Current vs. Forward Voltage
@ Ts = 25°C

$$I_F = f(V_F)$$

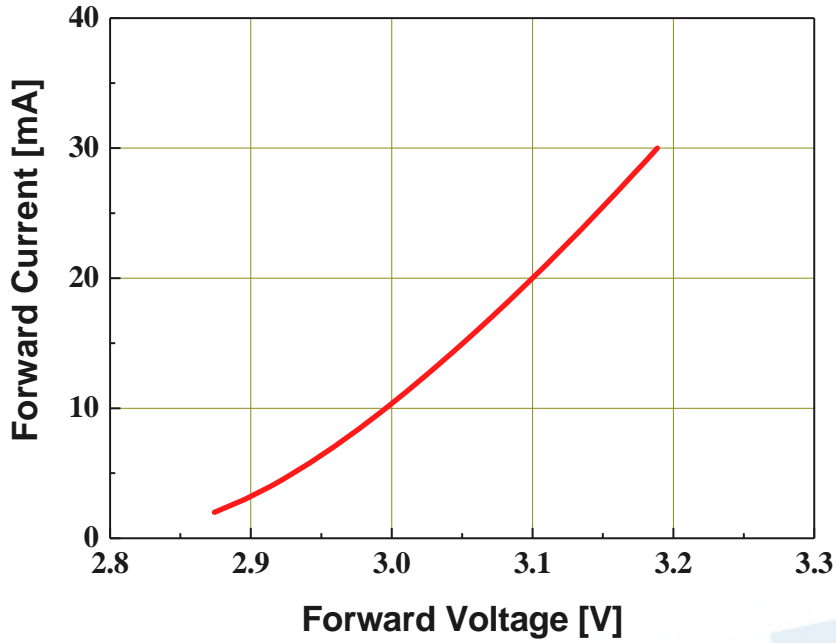

Relative Luminous Intensity vs. Forward Current
@ Ts = 25°C

$$\Phi_V / \Phi_V(20mA) = f(I_F)$$

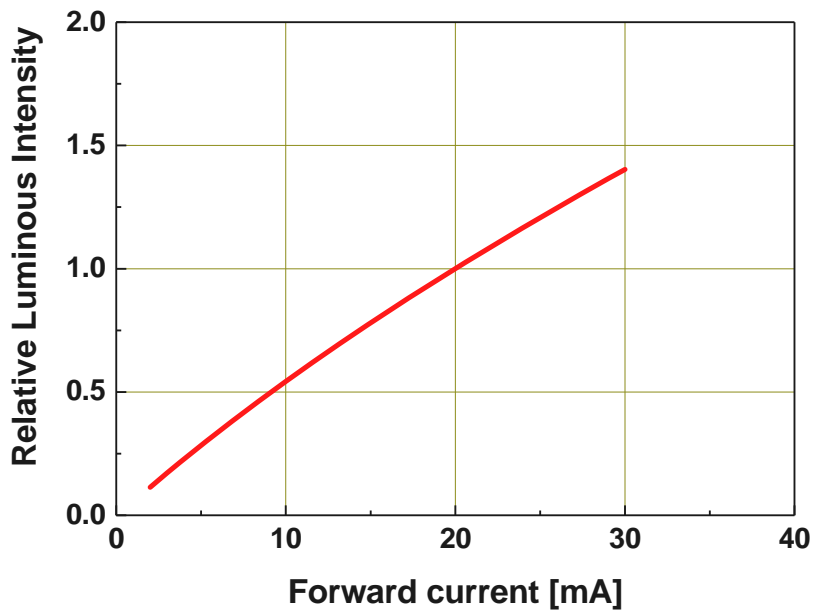

Dominant Wavelength vs. Forward Current
@ $T_s = 25^\circ\text{C}$

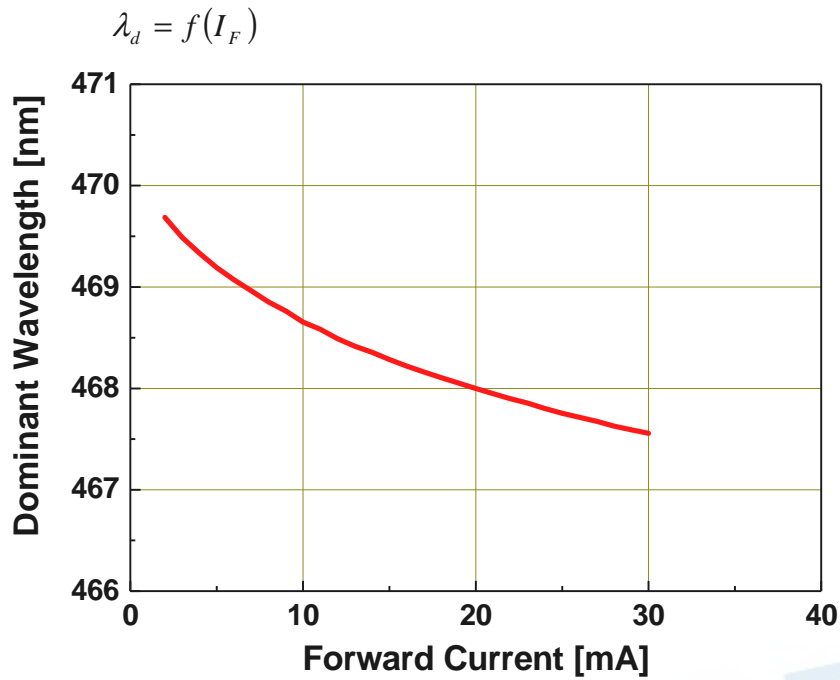

Relative Forward Voltage vs. Junction Temperature
@ $I_F = 20\text{mA}$

$\Delta V_F = V_F - V_F(25^\circ\text{C}) = f(T_j)$

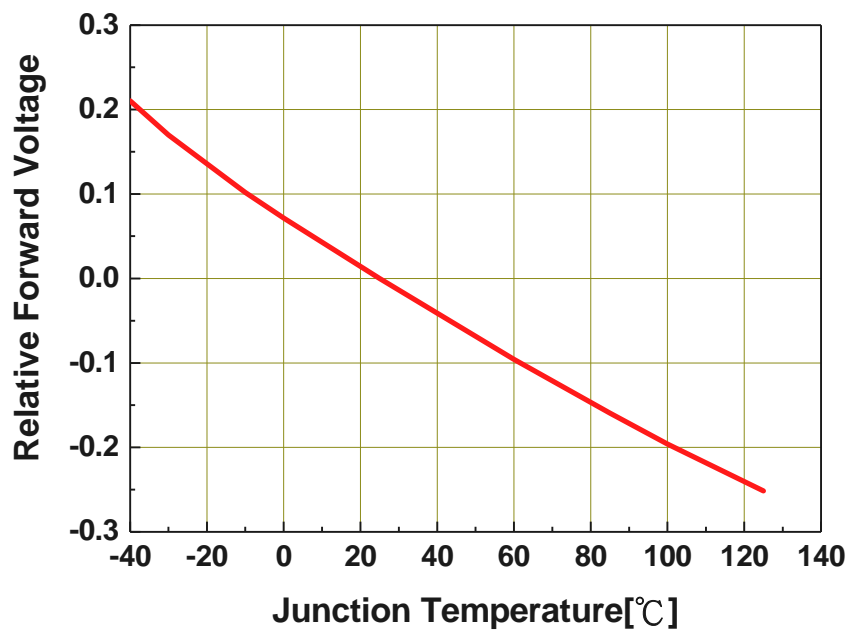

Relative Luminous Intensity vs. Junction Temperature

@ I_F=20mA

$$\Phi_v / \Phi_v(25^\circ C) = f(T_j)$$

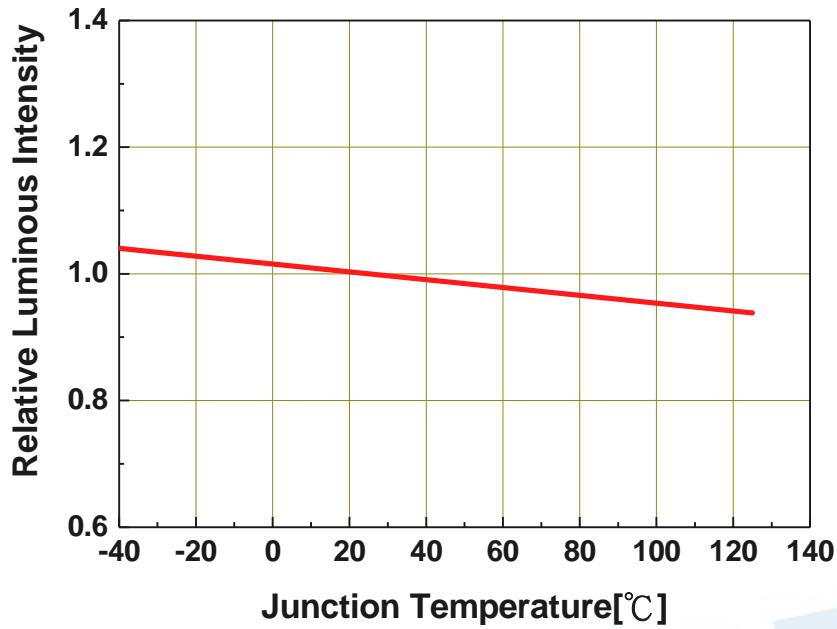

Relative Wavelength vs. Junction Temperature

@ I_F=20mA

$$\Delta\lambda_d = \lambda_d - \lambda_d(25^\circ C) = f(T_j)$$

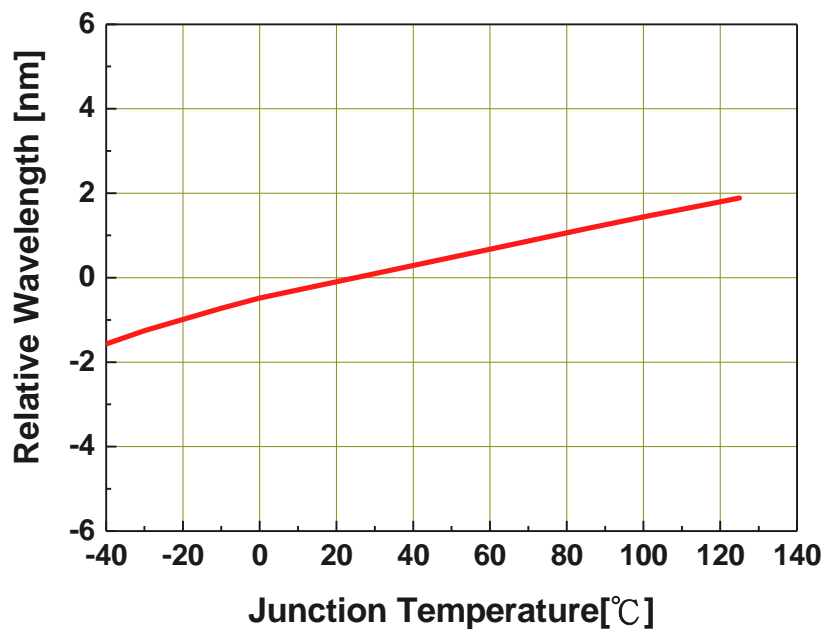

Forward Current Derating Curve

$$I_F = f(T_S)$$

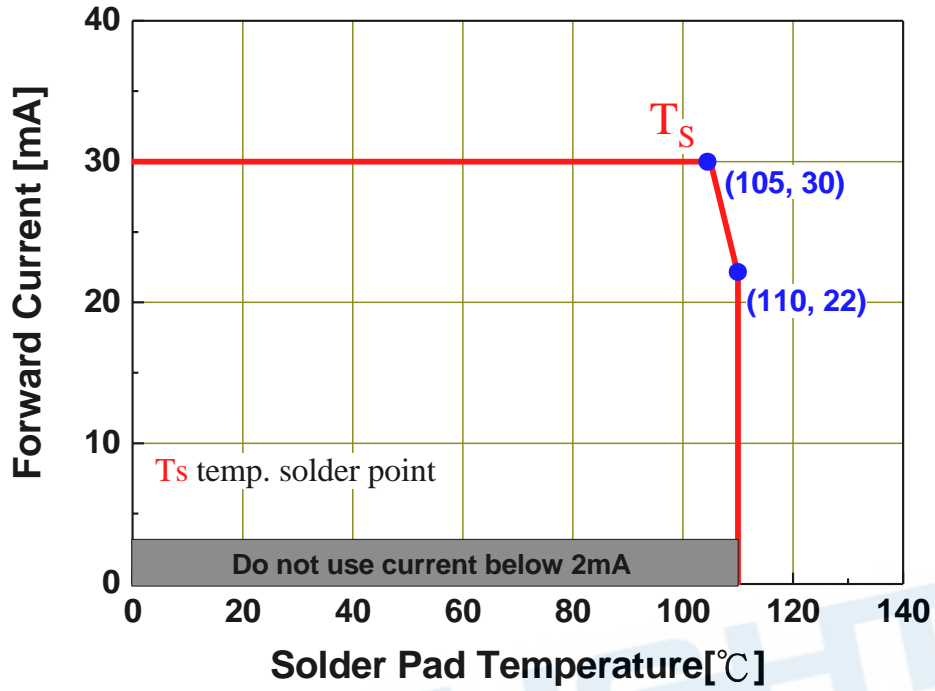

Permissible Pulse Handling Capability

D=Duty cycle , $T_s = 25^\circ\text{C}$

4. Binning Information

Luminous Intensity Bins

| Group Bin | Minimum Luminous Intensity (mcd) | Maximum Luminous Intensity (mcd) |
|-----------|----------------------------------|----------------------------------|
| L1 | 11.2 | 14 |
| L2 | 14 | 18 |
| M1 | 18 | 22.4 |
| M2 | 22.4 | 28 |
| N1 | 28 | 35.5 |
| N2 | 35.5 | 45 |
| P1 | 45 | 56 |
| P2 | 56 | 71 |
| Q1 | 71 | 90 |
| Q2 | 90 | 112 |
| R1 | 112 | 140 |
| R2 | 140 | 180 |
| S1 | 180 | 224 |
| S2 | 224 | 280 |
| T1 | 280 | 355 |
| T2 | 355 | 450 |
| U1 | 450 | 560 |
| U2 | 560 | 710 |
| V1 | 710 | 900 |
| V2 | 900 | 1120 |
| AA | 1120 | 1400 |
| AB | 1400 | 1800 |
| BA | 1800 | 2240 |
| BB | 2240 | 2800 |
| CA | 2800 | 3550 |
| CB | 3550 | 4500 |
| DA | 4500 | 5600 |
| DB | 5600 | 7100 |
| EA | 7100 | 9000 |
| EB | 9000 | 11200 |
| FA | 11200 | 14000 |
| FB | 14000 | 18000 |
| GA | 18000 | 22400 |

Notes:

1. Luminous flux measurement tolerance: $\pm 8\%$.
2. Highlighted Black Box is possible output bins.

Dominant Wavelength Bins

| Group Bin | Minimum Dominant Wavelength [nm] | Maximum Dominant Wavelength [nm] |
|-----------|----------------------------------|----------------------------------|
| 5963 | 459 | 463 |
| 6367 | 463 | 467 |
| 6771 | 467 | 471 |
| 7175 | 471 | 475 |
| 1015 | 510 | 515 |
| 1520 | 515 | 520 |
| 2025 | 520 | 525 |
| 2530 | 525 | 530 |
| 3035 | 530 | 535 |
| 5255 | 552 | 555 |
| 5558 | 555 | 558 |
| 5861 | 558 | 561 |
| 6164 | 561 | 564 |
| 6467 | 564 | 567 |
| 6770 | 567 | 570 |
| 7073 | 570 | 573 |
| 7376 | 573 | 576 |
| 7679 | 576 | 579 |
| 7982 | 579 | 582 |
| 8285 | 582 | 585 |
| 8588 | 585 | 588 |
| 8891 | 588 | 591 |
| 9194 | 591 | 594 |
| 9497 | 594 | 597 |
| 9700 | 597 | 600 |
| 0003 | 600 | 603 |
| 0306 | 603 | 606 |
| 0609 | 606 | 609 |
| 0912 | 609 | 612 |
| 1215 | 612 | 615 |
| 1518 | 615 | 618 |
| 1821 | 618 | 621 |
| 2124 | 621 | 624 |
| 2427 | 624 | 627 |
| 2730 | 627 | 630 |
| 3033 | 630 | 633 |
| 3336 | 633 | 636 |
| 3639 | 636 | 639 |

Notes:

1. Tolerance of Dominant Wavelength : ± 1 nm.

Forward Voltage Bins

| Bin code | Min Forward Voltage [V] | Max Forward Voltage [V] |
|----------|-------------------------|-------------------------|
| 1012 | 1.00 | 1.25 |
| 1215 | 1.25 | 1.50 |
| 1517 | 1.50 | 1.75 |
| 1720 | 1.75 | 2.00 |
| 2022 | 2.00 | 2.25 |
| 2225 | 2.25 | 2.50 |
| 2527 | 2.50 | 2.75 |
| 2730 | 2.75 | 3.00 |
| 3032 | 3.00 | 3.25 |
| 3235 | 3.25 | 3.50 |
| 3537 | 3.50 | 3.75 |
| 3740 | 3.75 | 4.00 |
| 4042 | 4.00 | 4.25 |
| 4245 | 4.25 | 4.50 |
| 4547 | 4.50 | 4.75 |
| 4750 | 4.75 | 5.00 |
| 5052 | 5.00 | 5.25 |
| 5255 | 5.25 | 5.50 |
| 5557 | 5.50 | 5.75 |
| 5760 | 5.75 | 6.00 |
| 6062 | 6.00 | 6.25 |
| 6265 | 6.25 | 6.50 |
| 6567 | 6.50 | 6.75 |
| 6770 | 6.75 | 7.00 |

Notes:

1. Forward voltage measurement tolerance: $\pm 0.05V$.
2. Forward voltage bins are defined at $I_F = 20mA$ operation.

5. Part Number

57-11-UB0200H-AM

Part number is designated with below details.

57-11 = Product family name.

UB = Color ^[1]

020 = Test current [mA]

0 = Lead Frame Type (0=Ag ; 1=Au ; 2=MLP)

H = Brightness Level (H=High ; M=Medium ; L=Low)

AM = Automotive application

Note

[1] Color :

| Symbol | Description |
|--------|---------------------------------|
| C | Cool White |
| N | Neutral White |
| W | Warm White |
| PA | Phosphor Converted Amber |
| PR | Phosphor Converted Red |
| UB | Blue |
| IB | Ice Blue |
| SB | Sky Blue |
| UP | Purple |
| UG | Green |
| UY | Yellow |
| UYG | Brilliant Yellow Green |
| UPG | Pale Green |
| UA | Amber |
| UR | Red |
| SR | Super Red |
| RGB | RGB-Color |
| PYG | Phosphor Converted Yellow Green |

6. Ordering Information

57-11-UB0200H-**ABCDEFGHIJKLM**-NO-AM

| Part Number of the 57-11 | Order Code |
|-----------------------------|-----------------------------------|
| 57-11-UB0200H-AM | 57-11-UB0200H-ABCDEFGHIJKLM-NO-AM |

Order code contains information with below details :

ABCD = min/max wavelength or CCT

EFGH = min./max. luminous flux in [lm] or luminous intensity in [mcd]

JKLM = min./max. forward voltage

NO = internal code

AM = Automotive Application

EVERLIGHT

7. Mechanical Dimension

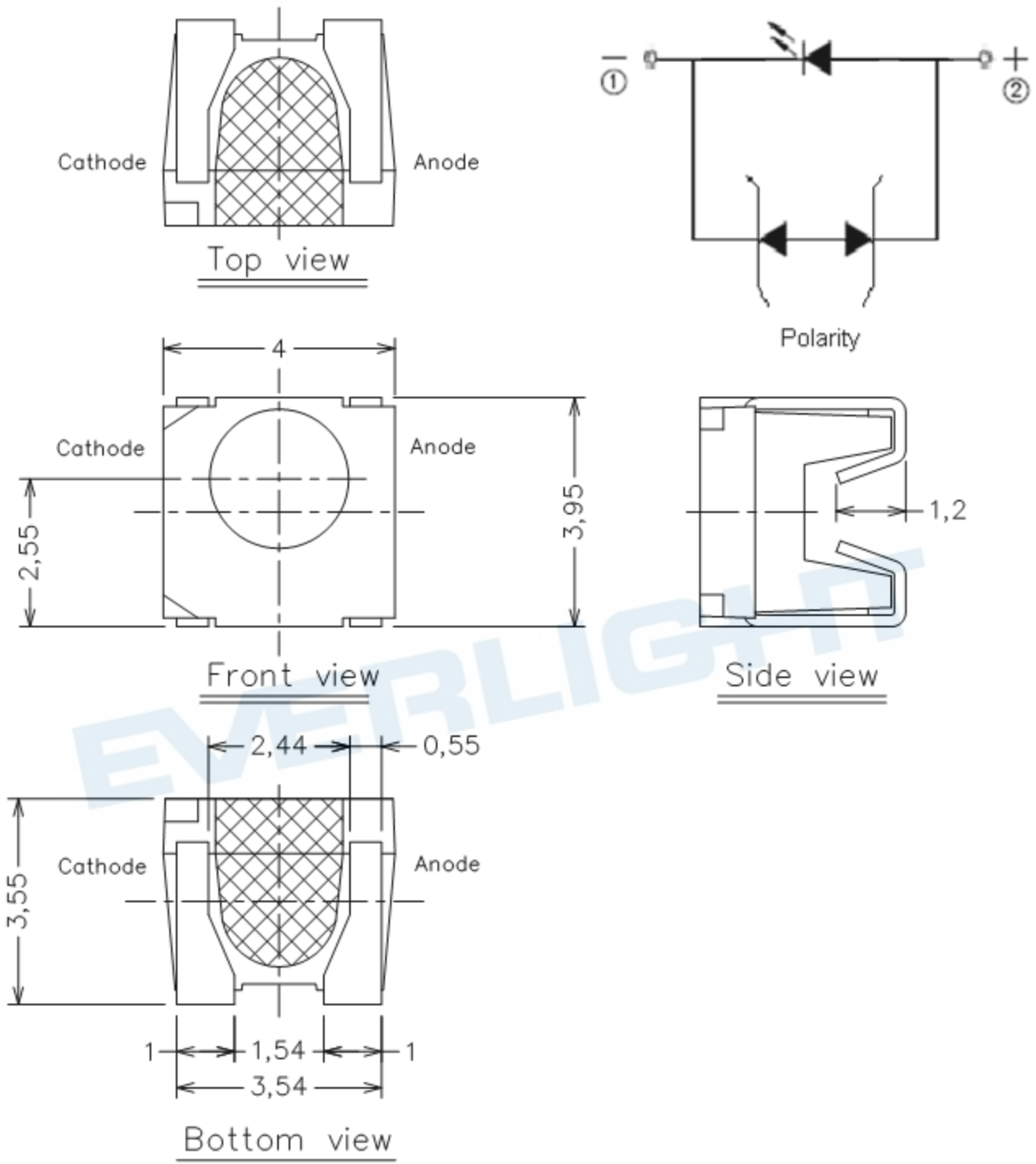

Notes:

1. Dimensions are in millimeters.
2. Tolerances unless mentioned are ± 0.1 mm.

8. Recommended Soldering Pad

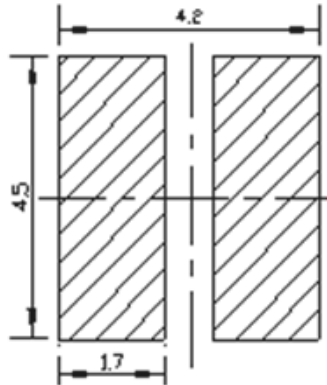

9. Reflow Soldering Profile

Soldering Condition (Reference: IPC/JEDEC J-STD-020D)

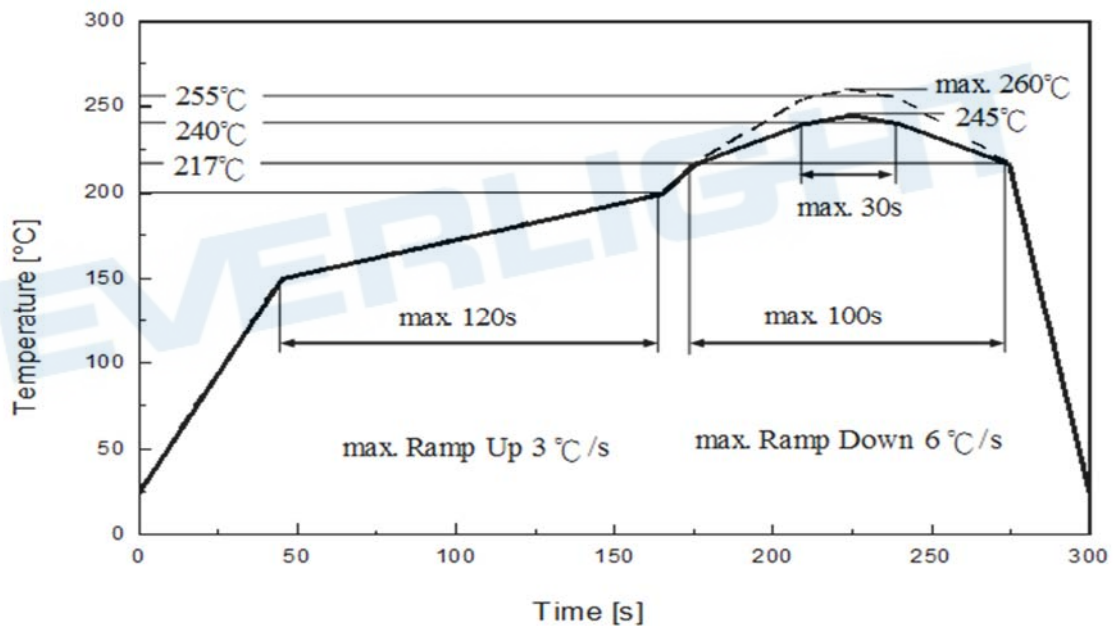

| Profile Feature | Pb-Free Assembly | Unit |
|--|------------------|---------|
| | Recommendation | |
| Ramp-up rate to preheat 25 °C to 150 °C | 3 | °C /sec |
| Time of soaking zone 150 °C to 200 °C | 120 | sec |
| Ramp-up rate to peak | 3 | °C /sec |
| Liquidus temperature | 217 | °C |
| Time above liquidus temperature | 100 | sec |
| Peak temperature (max.) | 260 | °C |
| Time within 5°C of the specified peak temperature | 30 | sec |
| Ramp-down Rate (max.) | 6 | °C /sec |

10. Packaging Information

• Product Labeling



- CPN : Customer's Product Number
- P/N : Everlight Part Number
- QTY : Packing Quantity
- CAT : Luminous Flux (Brightness) Bin
- HUE : Color Bin
- REF : Forward Voltage Bin
- LOT No : Lot Number

• Packing: Loaded Quantity 2000 pcs Per Reel

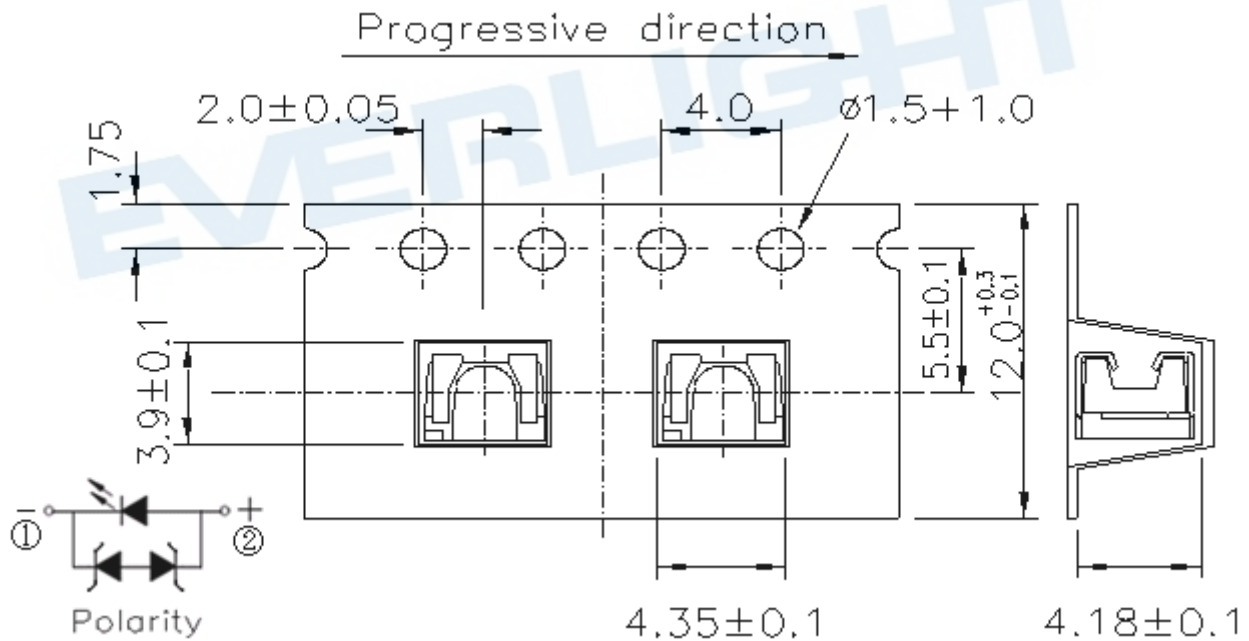

Notes:

1. Dimensions are in millimeters.

● **Reel Dimensions**

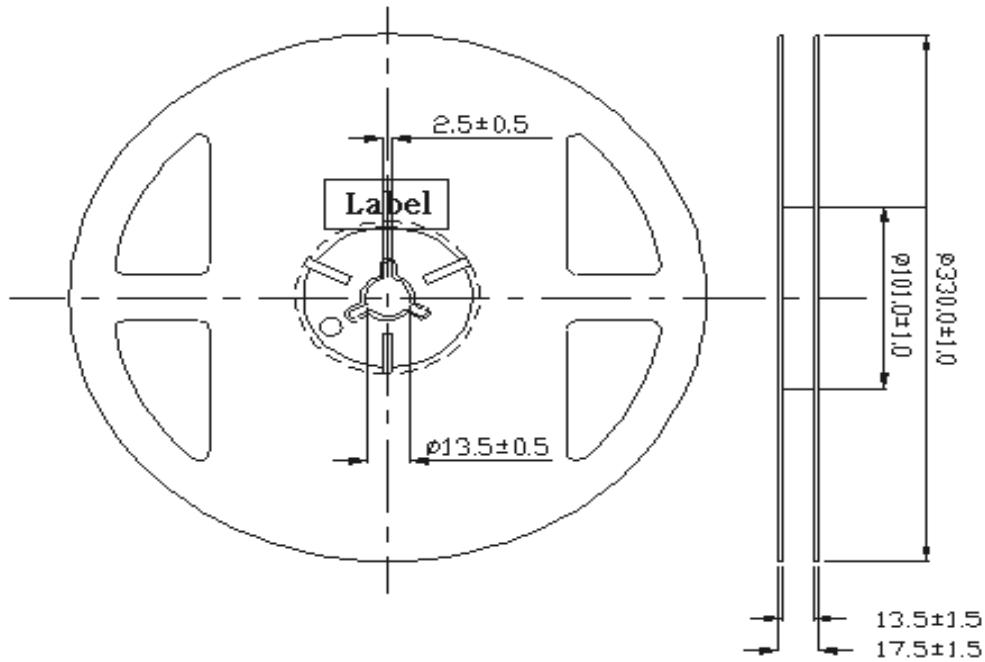

Notes:

1. Dimensions are in millimeters.

● **Moisture Resistant Packing Process**

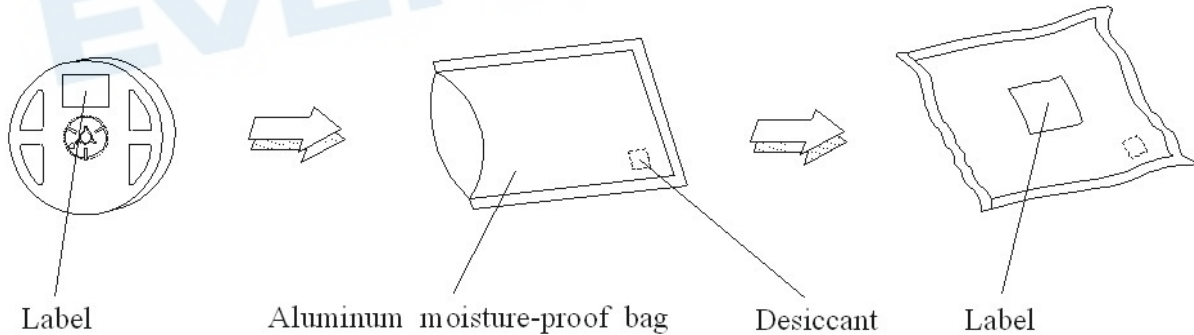

11. Precaution for Use

1. Over-current-proof

Customer must apply resistors for protection; otherwise slight voltage shift will cause big current change (burn out will happen).

2. Assemblies

Do not stack assemblies containing LEDs to prevent damage to the optical surface of LEDs. Forces applied to the optical surface may result in the surface being damaged.

3. Soldering Condition

3.1 When soldering, do not put stress on the LEDs during heating.

3.2 After soldering, do not warp the circuit board.

4. Soldering Iron

Each terminal is to go to the tip of soldering iron temperature less than 350°C for 3 seconds within once in less than the soldering iron capacity 25W. Leave two seconds and more intervals, and do soldering of each terminal. Be careful because the damage of the product is often started at the time of the hand solder.

5. Repairing

Repair should not be done after the LEDs have been soldered. When repairing is unavoidable, a double-head soldering iron should be used (as below figure). It should be confirmed beforehand whether the characteristics of the LEDs will or will not be damaged by repairing.

