

SMD ▪ Top View LEDs

50-615TZUMREC/L3444NEE/TR8-T



Features

- Top View White LEDs
- Wide viewing angle
- Soldering methods: IR reflow soldering
- Pb-free
- ESD protection
- The product itself will remain within RoHS compliant version.
- Compliance with EU REACH.
- Compliance Halogen Free .(Br <900 ppm ,Cl <900 ppm , Br+Cl < 1500 ppm).

Description

Due to the package design, 50-615TZ has wide viewing angle, low power consumption and white LEDs are devices which are materialized by combing blue chips and special phosphor. This feature makes the LED ideal for light guide application.

Applications

- Backlight for LCD Monitor/TV
- Light pipe application
- Indicator and backlight in office and family equipment
- General use

Device Selection Guide

Chip Materials	Emitted Color	Resin Color
InGaN	White	Water Clear

Absolute Ratings (T_{soldering}=25°C)

Parameter	Sym bol	Rating	Unit
Reverse Voltage *1	V _R	5	V
Forward Current *1	I _F	120	mA
Peak Forward Current (Duty 1/10 @10ms) *1	I _{FP}	240	mA
Power Dissipation	P _d	408	mW
Thermal Resistance Junction/solder point	R _{thj-s}	35	°C/W
Electrostatic Discharge(HBM) *3	ESD	5000	V
Operating Temperature	T _{opr}	-40 ~ +85	°C
Storage Temperature	T _{stg}	-40 ~ +100	°C
Junction temperature	T _j	≤ 115	°C
Soldering Temperature	T _{sol}	Reflow Soldering : 260 °C for 10 sec. Hand Soldering : 350 °C for 3 sec.	

Notes:

1. For each die.
2. The products are sensitive to static electricity and must be carefully taken when handling products.

Electro-Optical Characteristics (T_a=25°C)

Parameter	Symbol	Min.	Typ.	Max.	Unit	Condition
Luminous Flux	Φ	34	44	46	lm	I _F =120mA
Viewing Angle	2θ _{1/2}	-----	120	-----	deg	I _F =120mA
Forward Voltage	V _F	2.7	3.0	3.4	V	I _F =120mA

Note:

1. Tolerance of Luminous flux: ±7%.
2. Tolerance of Forward Voltage: ±0.05V.

Bin Range of Luminous Flux

Bin Code	Min.	Max.	Unit	Condition
34	34	35	lm	I _F =120mA
35	35	36		
36	36	37		
37	37	38		
38	38	39		
39	39	40		
40	40	41		
41	41	42		
42	42	43		
43	43	44		
44	44	45		
45	45	46		

Note:

Tolerance of Luminous flux: ±7%.

Bin Range of Forward Voltage

Bin Code	Min.	Max.	Unit	Condition
8	2.7	2.8	V	I _F =120mA
9	2.8	2.9		
A	2.9	3.0		
B	3.0	3.1		
C	3.1	3.2		
D	3.2	3.3		
E	3.3	3.4		

Note:

Tolerance of Forward Voltage: ±0.05V.

50-615TZUMREC/L3444NEE/TR8-T

Bin Range of Chromaticity Coordinates

Bin Code	CIE_x	CIE_y	Bin Code	CIE_x	CIE_y
NA0-3-2	0.2805	0.2600	NA0-3-4	0.2840	0.2550
	0.2770	0.2650		0.2805	0.2600
	0.2820	0.2720		0.2850	0.2670
NA0-4-1	0.2850	0.2670	NA0-4-3	0.2880	0.2620
	0.2850	0.2670		0.2880	0.2620
	0.2820	0.2720		0.2850	0.2670
NA0-4-2	0.2865	0.2795	NA0-4-4	0.2893	0.2743
	0.2893	0.2743		0.2920	0.2690
	0.2893	0.2743		0.2920	0.2690
NB5-3-1	0.2865	0.2795	NB5-3-3	0.2893	0.2743
	0.2910	0.2870		0.2935	0.2815
	0.2935	0.2815		0.2960	0.2760
NB5-3-2	0.2935	0.2815	NB5-3-4	0.2960	0.2760
	0.2910	0.2870		0.2935	0.2815
	0.2950	0.2940		0.2975	0.2885
NB5-3-2	0.2975	0.2885	NB5-3-4	0.3000	0.2830
	0.2975	0.2885		0.3000	0.2830
	0.2950	0.2940		0.2975	0.2885
NB5-3-2	0.2990	0.3010	NB5-3-4	0.3015	0.2955
	0.3015	0.2955		0.3040	0.2900

The C.I.E. 1931 Chromaticity Diagram

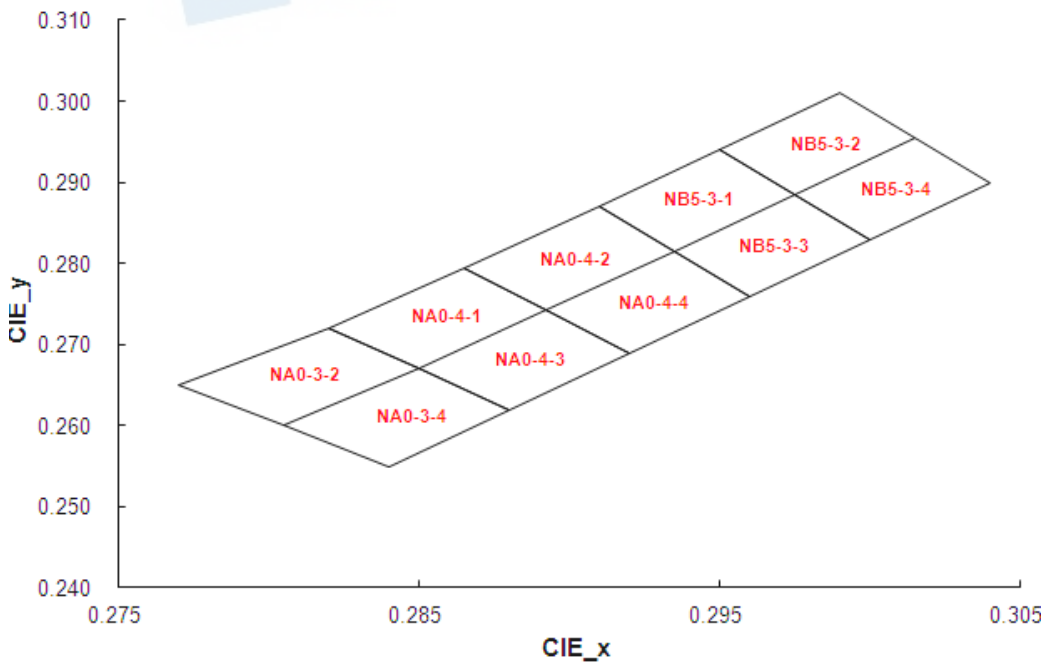

Note:

1. The value is based on driving current by 120mA.
2. Tolerance of Chromaticity Coordinates: ± 0.005 .

Typical Electro-Optical-Thermal Characteristics Curves

1. Spectrum Distribution

($T_A=25^{\circ}\text{C}$, $I_F=120\text{mA}$)

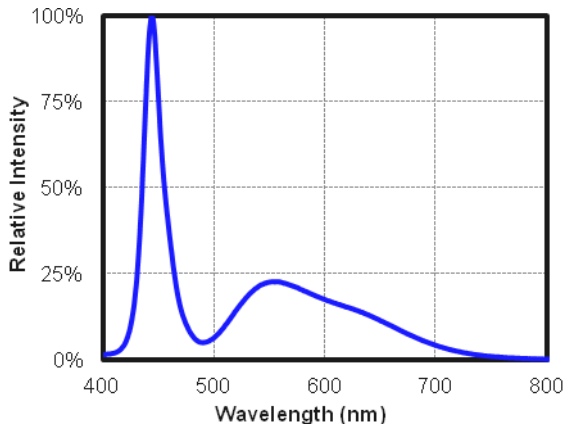

2. Relative Luminous Flux vs. Forward Current

($T_A=25^{\circ}\text{C}$)

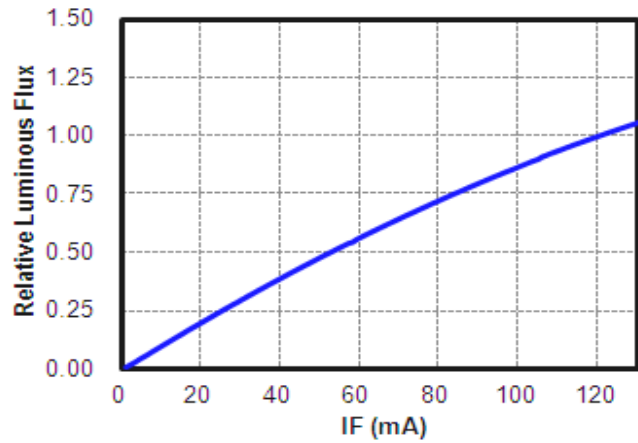

3. Relative Forward Voltage vs. Forward Current

($T_A=25^{\circ}\text{C}$)

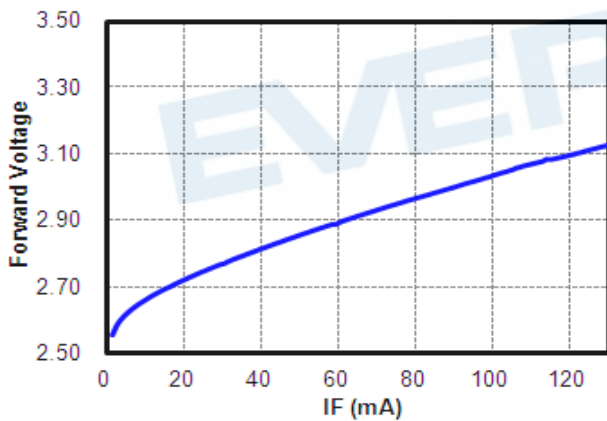

4. Radiation Diagram

($T_A=25^{\circ}\text{C}$, $I_F=120\text{mA}$)

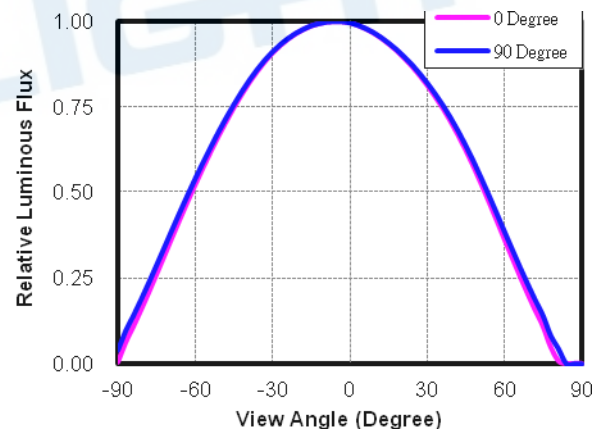

Typical Electro-Optical-Thermal Characteristics Curves

5. Relative Luminous Flux vs. Ambient Temperature
($I_F=120\text{mA}$)

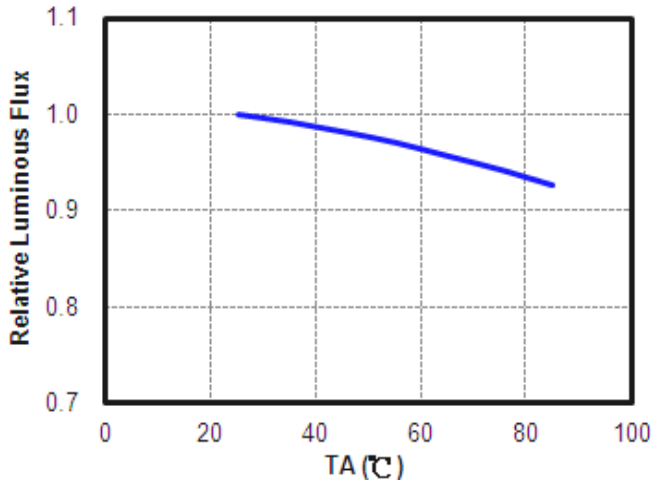

6. Forward Voltage vs. Ambient Temperature
($I_F=120\text{mA}$)

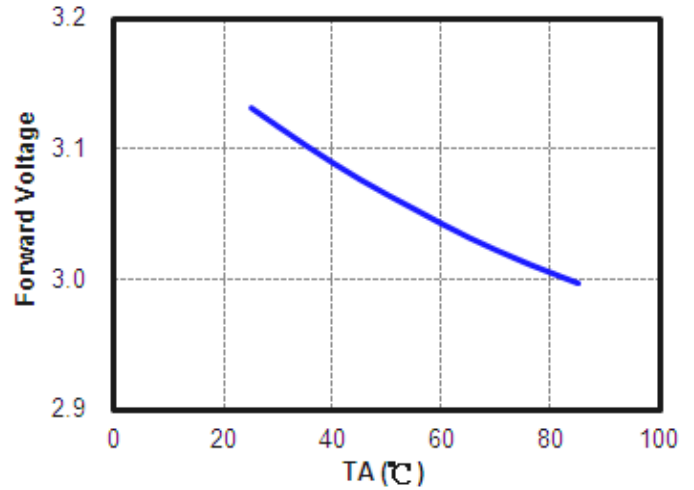

7. Chromaticity Coordinates vs. Ambient Temperature
($I_F=120\text{mA}$)

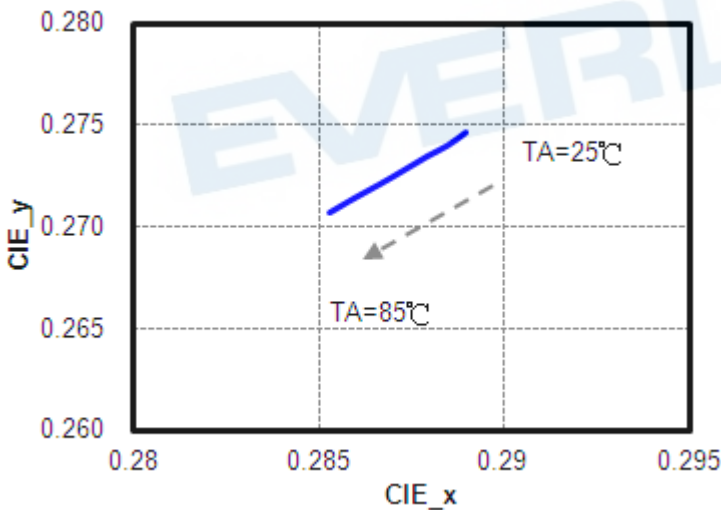

8. Forward Current De-rating Curve

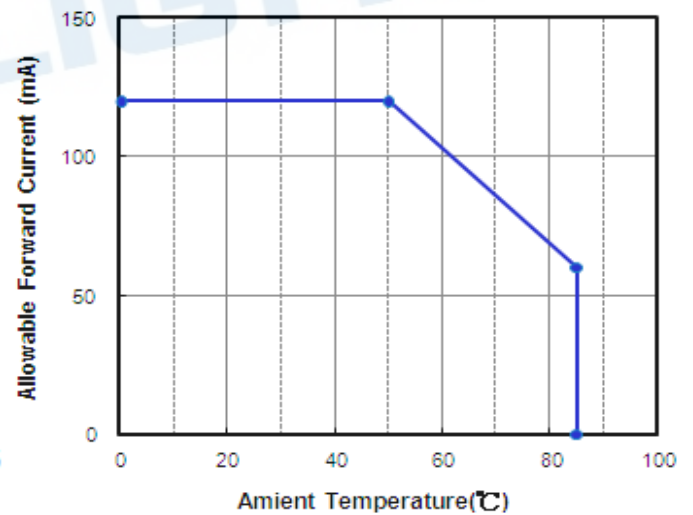

Package Dimension

4014 (12.6.5)

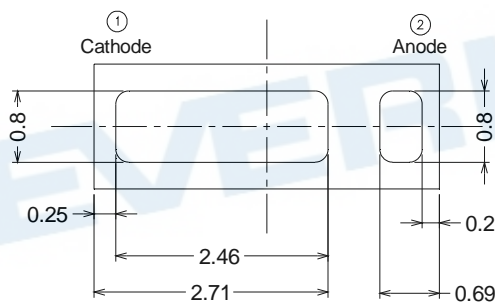
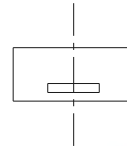
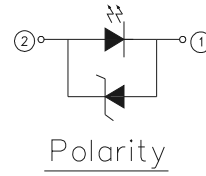
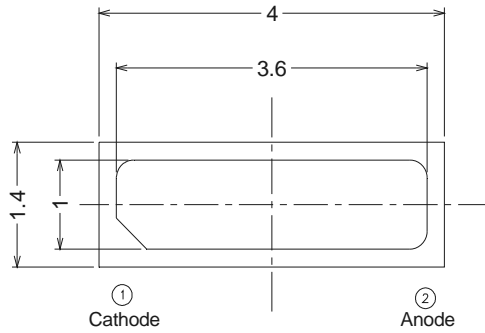

Bot. view

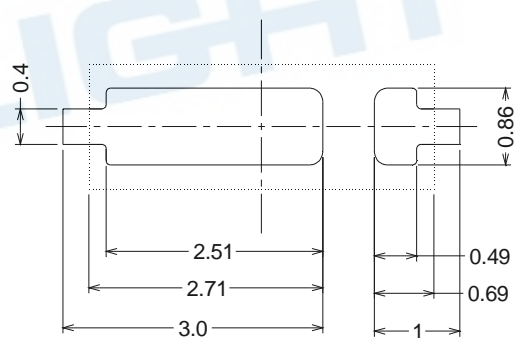

Soldering pattern

Note:

The tolerance unless mentioned is $\pm 0.1\text{mm}$, unit = mm

Moisture Resistant Packing Materials

Label Explanation

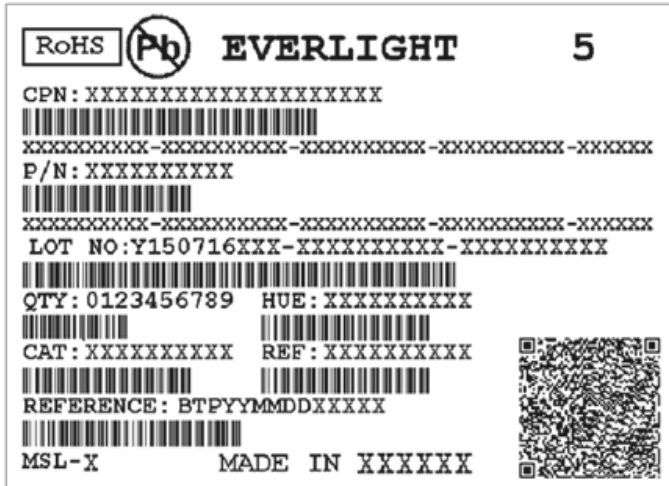

- CPN: Customer's Product Number
- P/N: Product Number
- QTY: Packing Quantity
- CAT: Luminous Intensity Rank
- HUE: Chromaticity Coordinates
- REF: Forward Voltage Rank
- LOT No: Lot Number

Reel Dimensions

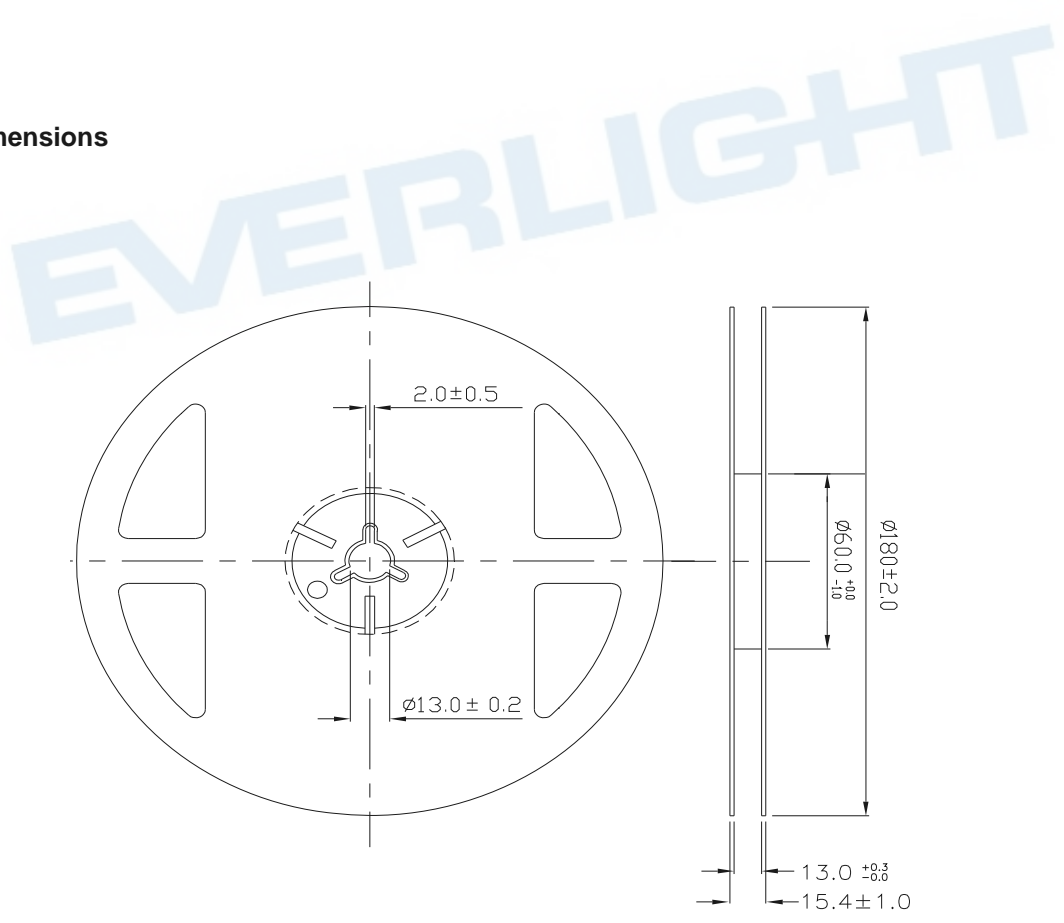

Note:
Tolerances unless mentioned ± 0.1 mm. Unit = mm

Carrier Tape Dimensions: Loaded Quantity 1000/2000 pcs. Per Reel

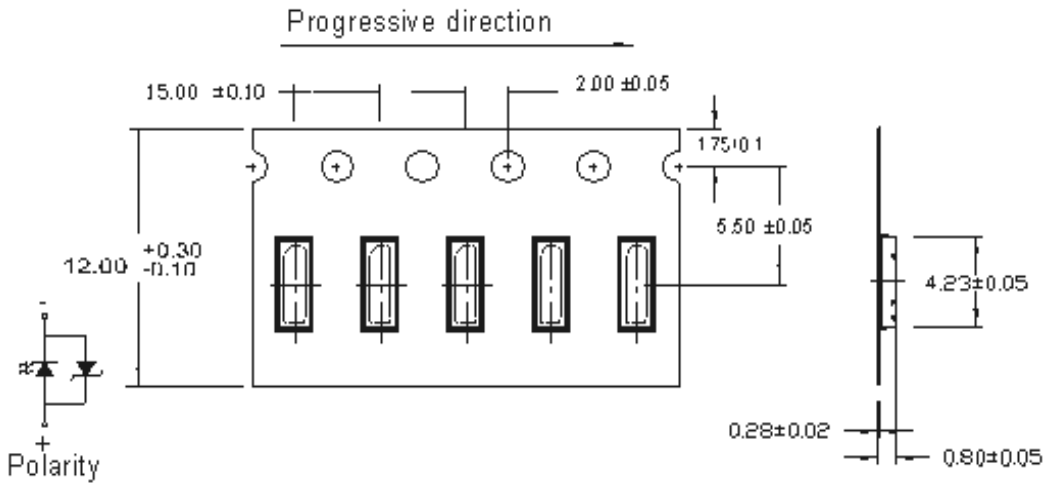

Note:
Tolerance unless mentioned is $\pm 0.1\text{mm}$; Unit = mm

Moisture Resistant Packing Process

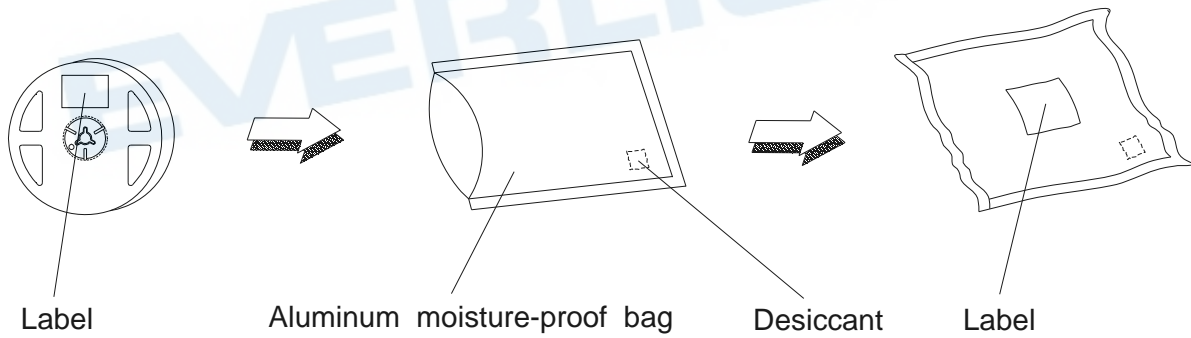

Reliability Test Items and Conditions

The reliability of products shall be satisfied with items listed below.
Confidence level : 90%
LTPD : 10%

No.	Item	Test Conition		Test Hours/ Times	Criteria (at std. IF)
		Temp./ Humidity	IF (mA)		
1	Reflow Soldering	Temp.: 260°C ±5°C Max. 10 sec.		2 times	ΔIv < ±15% ΔVF < ±15%
2	Thermal Cycle	-40°C ~ 100°C 30min. (5min.) 30min.		200 cycles	Iv > 70%, VF ±10%,
3	Thermal Shock	-40°C ~ 100°C 20min. (<15sec.) 20min.		200 cycles	
4	Low Temp. Storage	TA=-40°C	--	1000 hrs	
5	High Temp. Storage	TA=100°C	--	1000 hrs	
6	Temp. Humidity Storage	TA=60°C / 90%RH	--	1000 hrs	
7	Steady State Operating Life of Low Temp.	TA=-40°C	120	1000 hrs	
8	Steady State Operating Life Condition 1	TA=25°C / Room Hum.	120	1000 hrs	
9	Steady State Operating Life Condition 2	TA=60°C	120	1000 hrs	
10	Steady State Operating Life of High Temp.	TA=85°C	60	1000 hrs	
11	Steady State Operating Life of High Humidity Heat	TA=60°C / 90%RH	120	1000 hrs	

※ Sampling for each test item: 22 (pcs.)

Precautions for Use

1. Over-current-proof

Customer must apply resistors for protection, otherwise slight voltage shift will cause big current change (Burn out will happen).

2. Storage

2.1 Do not open moisture proof bag before the products are ready to use.

2.2 Before opening the package: The LEDs should be used within one year and kept at 30°C or less and 70%RH or less.

2.3 After opening the package: We recommend that the LED should be soldered quickly (within 3 days). The soldering condition is 30°C or less and 60%RH or less. If unused LEDs remain, it should be stored in moisture proof packages.

2.4 If the moisture absorbent material (silica gel) has faded away or the LEDs have exceeded the storage time, baking treatment should be performed using the following conditions.

Baking treatment: 60±5°C for 24 hours. (One time only)

3. Soldering Condition

3.1 Pb-free solder temperature profile

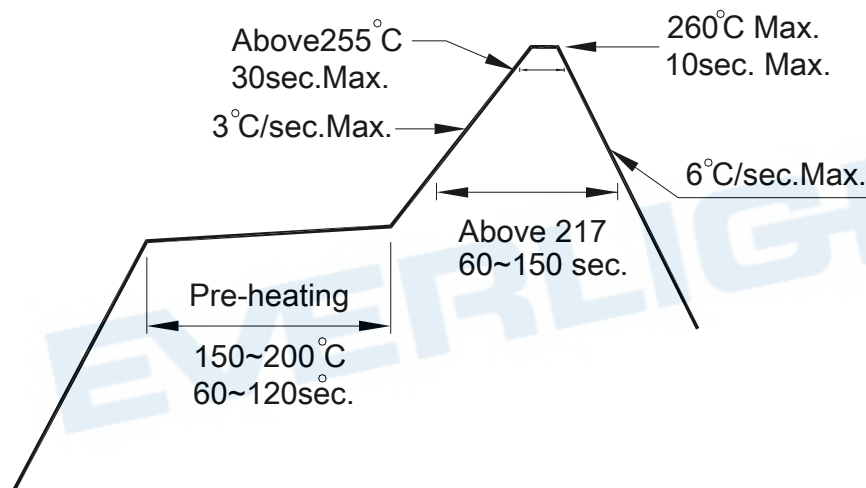

3.2 Reflow soldering should not be done more than two times.

3.3 When soldering, do not put stress on the LEDs during heating.

3.4 After soldering, do not warp the circuit board.

4. Soldering Iron

Each terminal is to go to the tip of soldering iron temperature less than 350°C for 3 seconds within once in less than the soldering iron capacity 25W. Leave two seconds and more intervals, and do soldering of each terminal. Be careful because the damage of the product is often started at the time of the hand solder.

5. Repairing

Repair should not be done after the LEDs have been soldered. When repairing is unavoidable, a double-head soldering iron should be used (as below figure). It should be confirmed beforehand whether the characteristics of the LEDs will or will not be damaged by repairing.

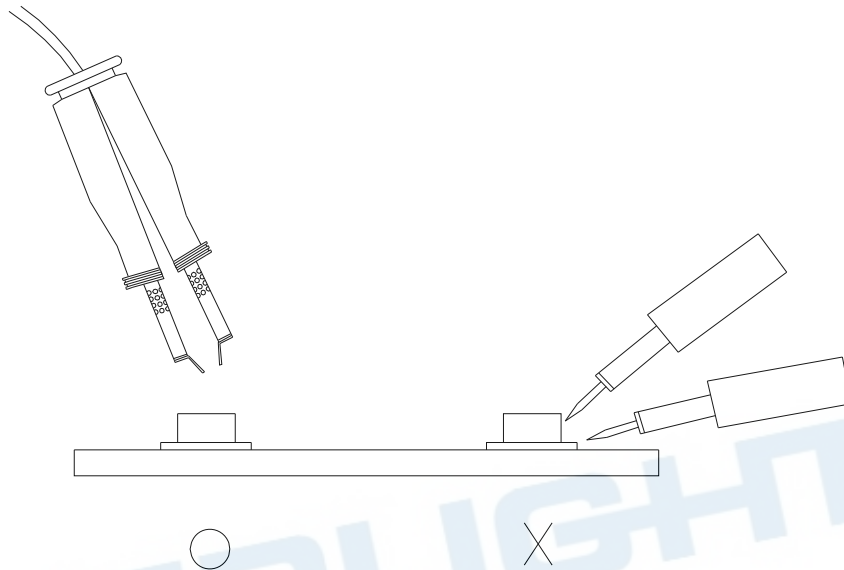

6. Handling Indications

During processing, mechanical stress on the surface should be minimized as much as possible. Sharp objects of all types should not be used to pierce the sealing compound

EVERLIGHT ELECTRONICS CO., LTD.

Office: No.6-8, Zhonghua Rd.

Shulin Dist., New Taipei City, 23860, Taiwan, R.O.C

Tel: 886-2-22685-6688,

Fax: 886-22685-6880,

<http://www.everlight.com>