

Shwo(F)

1W Series

爍 (F)

“Shwo(F) [Shuo(F)] is the English translation for the Chinese word meaning Twinkle and is often used as a description of stars or other bright, celestial objects as seen from Earth. This word is a relevant description for this bright, compact Everlight LED package.”

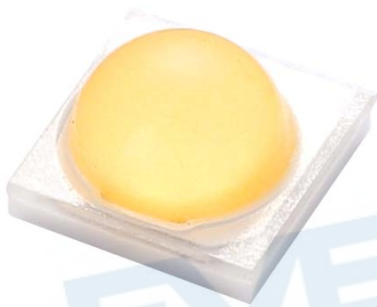

Introduction

The Shwo(F) series is a surface-mount high-power device featuring high brightness combined with a compact size that is suitable for all kinds of lighting applications such as general illumination, flash, spot, signal, industrial and commercial lighting. The Shwo(F) series is one of the most promising devices in Everlight's high power product offering and is ready to face the challenges of today's Solid-State Lighting requirements.

Features

- ◆ Small package with high efficiency
- ◆ ESD protection up to 8KV
- ◆ Soldering method: SMT
- ◆ Binning Parameters: Brightness, Forward Voltage ,Wavelength and Chromaticity
- ◆ Moisture Sensitivity Level: 1
- ◆ RoHS compliant
- ◆ Matches ANSI binning
- ◆ The product itself will remain within RoHS compliant version.
- ◆ Compliance with EU REACH.
- ◆ Compliance Halogen Free .(Br<900ppm,Cl<900ppm,Br+Cl<1500ppm)

Applications

- ◆ General Lighting
- ◆ Decorative and Entertainment Lighting
- ◆ Signal and Symbol Luminaries for orientation marker lights (e.g. steps, exit ways, etc.)
- ◆ Agriculture Lighting

Table of Contents

Absolute Maximum Ratings	4
JEDEC Moisture Sensitivity	4
Luminous Flux Characteristics for the Shwo(F) series	5
PN of the Shwo(F) Series: White LEDs.....	9
PN of the Shwo(F) High Luminous Series: White LEDs.....	10
PN of the Shwo(F) Super High Luminous Series: White LEDs	11
PN of the Shwo(F) series: Color LEDs	13
Product Binning	14
White Bin Structure.....	16
Optical Characteristics	21
Pad Configuration	23
Wavelength Characteristics	25
Typical Light Output Characteristic.....	26
V.S. Thermal Pad Temperature.....	26
Typical Relative Luminous Flux V.S. Forward Current.....	28
Current Derating Curves.....	29
Emitter Tape Packaging.....	31
Emitter Reel Packaging	32
Product Labeling.....	32
Reliability Data.....	33
Storage Conditions	34
Thermal Management	34
DISCLAIMER.....	35
Revision History	36

Product Nomenclature

The product name is designated as below:

ELSWF – ABCDE – FGHIJ – V1234

Designation:

AB = min. luminous flux (lm) or radiation power (mW) performance

C = radiation pattern [1]

D = color [2]

E = proposed operating power [3]

F = reserved for future product offerings

G = Internal code

H = packaging type [4]

IJ = internal code

V = forward voltage bin

1234 = color bin or CCT bin

Notes

1. Table of radiation patterns

Symbol	Description
1	Lambertian

2. Table of color offerings:

Symbol	Color	Dominant wavelength range
C	Cool-White	4745~7050K
N	Neutral-White	3710~4745K
M	Warm-White	2580~3710K
L	Royal-Blue	445~460nm

3. Table of proposed operating power:

Symbol	Description
1	1W

4. Table of packaging types:

Symbol	Description
P	Tape

Absolute Maximum Ratings

Parameter	Symbol	Ratings	Unit
Max. DC Forward Current (mA)	I _F	1000 / 1500 _[1]	mA
Max. Peak Pulse Current (mA)	I _{Pulse}	1250 / 1500 _[2]	mA
Max. ESD Resistance	V _B	8000	V
Reverse Voltage	V _R	Note 3	V
Thermal Resistance	R _{th}	5	°C/W
Max. Junction Temperature	T _J	150	°C
Operating Temperature	T _{Op}	-40 ~ +100	°C
Storage Temperature	T _{Stg}	-40 ~ +100	°C
Max. Soldering Temperature	T _{Sol}	260	°C
Max. Allowable Reflow Cycles	n/a	2	cycles

Notes:

1. Shwo(F) series Maximum forward current is 1000mA (Thermal Pad=25°C), Shwo(F) high and super high luminous series is 1500mA (Thermal Pad=25°C).
2. Shwo(F) series Maximum peak pulse current is 1250mA (Duty cycle = 1/10@1KHZ), Shwo(F) high and super high luminous series is 1500mA.
3. The Shwo(F) series LEDs are not designed for reverse bias use

JEDEC Moisture Sensitivity

Level	Floor Life		Soak Requirements Standard	
	Time (hours)	Conditions	Time (hours)	Conditions
1	Unlimited	≤ 30°C / 85% RH	168 (+5/-0)	85°C / 85% RH

Luminous Flux Characteristics for the Shwo(F) series
@ Thermal Pad Temperature = 25°C

Color	Part Number	1W	
		Minimum Luminous Flux(lm) _[1]	Drive Current (mA)
Cool White	ELSWF-JJ1CX	175	350
	ELSWF-J81CX	170	350
	ELSWF-JH1CX	165	350
	ELSWF-J71CX	160	350
	ELSWF-J61CX	150	350
	ELSWF-J51CX	140	350
	ELSWF-J41CX	130	350
Neutral White	ELSWF-J81NX	170	350
	ELSWF-J71NX	160	350
	ELSWF-J51NX	140	350
	ELSWF-J41NX	130	350
	ELSWF-J31NX	120	350
Warm White	ELSWF-J71MX	160	350
	ELSWF-JG1MX	155	350
	ELSWF-J61MX	150	350
	ELSWF-JF1MX	145	350
	ELSWF-J41MX	130	350

	ELSWF-J31MX	120	350
	ELSWF-J21MX	110	350

Notes:

1. Luminous flux measurement tolerance: $\pm 8\%$.
2. The data of luminous flux measured at thermal pad= 25°C
3. Typical luminous flux or light output performance is operated within the condition guided by this datasheet.

EVERLIGHT

Luminous Flux Characteristics for the Shwo(F) series

@ Thermal Pad Temperature = 85°C

Color	Part Number	1W	
		Minimum Luminous Flux(lm) _[1]	Drive Current (mA)
	ELSWF-JJ1CX	158	350
	ELSWF-J81CX	153	350
	ELSWF-JH1CX	150	350
	ELSWF-J71CX	145	350
Cool White	ELSWF-J61CX	135	350
	ELSWF-J51CX	126	350
	ELSWF-J41CX	117	350
Neutral White	ELSWF-J81NX	153	350
	ELSWF-J71NX	145	350
	ELSWF-J51NX	126	350
	ELSWF-J41NX	117	350
	ELSWF-J31NX	108	350
Warm White	ELSWF-J71MX	144	350
	ELSWF-JG1MX	140	350
	ELSWF-J61MX	135	350
	ELSWF-JF1MX	131	350
	ELSWF-J41MX	117	350

	ELSWF-J31MX	108	350
	ELSWF-J21MX	100	350

Notes:

1. Luminous flux measurement tolerance: $\pm 8\%$.
2. The data of luminous flux measured at thermal pad=85°C
3. Typical luminous flux or light output performance is operated within the condition guided by this datasheet.

EVERLIGHT

PN of the Shwo(F) Series: White LEDs

The table below is a list of part numbers for the Everlight Shwo(F) series White LED. All parts listed match ANSI binning standards. Bin offerings of 6500K, 5700K, 3000K, 2700K listed and currently available. CRI is also listed with min 70 to 80. Typical view angle is 120°. These clearly listed binning options allow for proper design and implementation into lighting applications. The Order Codes below are currently available White Shwo(F) LEDs.

For Example: If you order product using P/N **ELSWF-J51C1-0FPGS-C5700**, you will be specifying:



Color Variant	Radiation Pattern	CRI	CCT	Forward Voltage (V)	Minimum Luminous Flux (lm)
Cool White	Lambertian	70	57K-1,57K-2, 57K-3,57K-4	2.65~2.95(U4) 2.95~3.25(V1) 3.25~3.55(V2)	140

White Shwo(F) series LEDs at 350mA are listed below @ 25°C.

Order Code of ELSWF	Minimum Luminous Flux (lm) @ Thermal Pad Temperature 85°C			Typ. Luminous Flux (lm) @ Thermal Pad Temperature 85°C			CCT (K) Wavelength (nm)	Forward Voltage (V)	CRI (Min.)
	350 mA	700 mA	1000 mA	350 mA	700 mA	1000 mA			
ELSWF-J51C1-0FPGS-C6500	126 (140)	226 (252)	302 (336)	139 (155)	252 (280)	334 (372)	65K-1~65K-4	2.65~3.55	70
ELSWF-J41C1-0FPHS-C6500	117 (130)	211 (235)	283 (315)	130 (145)	234 (260)	315 (350)	65K-1~65K-4	2.65~3.55	80
ELSWF-J51C1-0FPGS-C5700	126 (140)	226 (252)	302 (336)	139 (155)	252 (280)	334 (372)	57K-1~57K-4	2.65~3.55	70
ELSWF-J41C1-0FPHS-C5700	117 (130)	211 (235)	283 (315)	130 (145)	234 (260)	315 (350)	57K-1~57K-4	2.65~3.55	80
ELSWF-J51C1-0FPGS-C5000	126 (140)	226 (252)	302 (336)	139 (155)	252 (280)	334 (372)	50K-1~50K-4	2.65~3.55	70
ELSWF-J41C1-0FPHS-C5000	117 (130)	211 (235)	283 (315)	130 (145)	234 (260)	315 (350)	50K-1~50K-4	2.65~3.55	80
ELSWF-J41N1-0FPGS-C4000	117 (130)	211 (235)	283 (315)	130 (145)	234 (260)	315 (350)	40K-1~40K-4	2.65~3.55	70
ELSWF-J31N1-0FPHS-C4000	108 (120)	196 (218)	259 (288)	118 (132)	214 (238)	283 (315)	40K-1~40K-4	2.65~3.55	80
ELSWF-J21M1-0FPHS-C3500	100 (110)	180 (200)	237 (264)	108 (121)	196 (218)	261 (290)	35K-1~35K-4	2.65~3.55	80
ELSWF-J21M1-0FPHS-C3000	100 (110)	180 (200)	237 (264)	108 (121)	196 (218)	261 (290)	30K-1~30K-4	2.65~3.55	80
ELSWF-J21M1-0FPHS-C2700	100 (110)	180 (200)	237 (264)	108 (121)	196 (218)	261 (290)	27K-1~27K-4	2.65~3.55	80

Notes:

1. (value in bracket): Lminous flux @ 25°C, for reference only
2. CRI measurement tolerance: ±2.
3. Each 1W white PN is based on the min. bin, and includes two adjacent bins.

PN of the Shwo(F) High Luminous Series: White LEDs

The table below is a list of part numbers for the Everlight Shwo(F) high luminous series White LED.

All parts listed match ANSI binning standards. Bin offerings of 6500K, 5700K, 3000K, 2700K are listed and currently available. CRI is also listed with min 70 to 80. Typical view angle is 120°. These clearly listed binning options allow for proper design and implementation into lighting applications. The Order Codes below are currently available White Shwo(F) LEDs.

For Example: If you order product using P/N **ELSWF-J61C1-5FPGS-C5700**, you will be specifying:



Color Variant	Radiation Pattern	CRI	CCT	Forward Voltage (V)	Minimum Luminous Flux (lm)
Cool White	Lambertian	70	57K-1,57K-2, 57K-3,57K-4	2.95~3.25(V1) 3.25~3.55(V2) 3.55~3.85(V3)	160

White Shwo(F) series LEDs at 350mA are listed below @ 25°C.

Color	Order Code of ELSWF	Minimum Luminous Flux (lm) @ Thermal Pad Temperature 85°C			Typ. Luminous Flux (lm) @ Thermal Pad Temperature 85°C			CCT (K) Wavelength (nm)	Forward Voltage (V)	CRI (Min.)
		350 mA	700 mA	1000 mA	350 mA	700 mA	1000 mA			
Cool White 6500K	ELSWF-J61C1-5FPGS-C6500	135 (150)	251 (280)	340 (378)	150 (165)	276 (307)	375 (416)	65K-1~65K-4	2.65~3.55	70
	ELSWF-J51C1-5FPHS-C6500	126 (140)	234 (260)	318 (353)	140 (155)	258 (286)	350 (388)	65K-1~65K-4	2.65~3.55	80
Cool White 5700K	ELSWF-J61C1-5FPGS-C5700	135 (150)	251 (280)	340 (378)	150 (165)	276 (307)	375 (416)	57K-1~57K-4	2.65~3.55	70
	ELSWF-J51C1-5FPHS-C5700	126 (140)	234 (260)	318 (353)	140 (155)	258 (286)	350 (388)	57K-1~57K-4	2.65~3.55	80
Cool White 5000K	ELSWF-J61C1-5FPGS-C5000	135 (150)	251 (280)	340 (378)	150 (165)	276 (307)	375 (416)	50K-1~50K-4	2.65~2.95	70
	ELSWF-J51C1-5FPHS-C5000	126 (140)	234 (260)	318 (353)	140 (155)	258 (286)	350 (388)	50K-1~50K-4	2.65~3.55	80
Neutral White 4000K	ELSWF-J51N1-5FPGS-C4000	126 (140)	234 (260)	318 (353)	140 (155)	258 (286)	350 (388)	40K-1~40K-4	2.65~3.55	70
	ELSWF-J41N1-5FPHS-C4000	117 (130)	218 (242)	295 (328)	130 (143)	240 (266)	324 (360)	40K-1~40K-4	2.65~3.55	80
Warm White 3500K	ELSWF-J31M1-5FPHS-C3500	108 (120)	196 (218)	259 (288)	118 (132)	214 (238)	283 (315)	35K-1~35K-4	2.65~3.55	80
Warm White 3000K	ELSWF-J31M1-5FPHS-C3000	108 (120)	196 (218)	259 (288)	118 (132)	214 (238)	283 (315)	30K-1~30K-4	2.65~3.55	80
Warm White 2700K	ELSWF-J31M1-5FPHS-C2700	108 (120)	196 (218)	259 (288)	118 (132)	214 (238)	283 (315)	27K-1~27K-4	2.65~3.55	80

Notes:

- (value in bracket): Luminous flux @ 25°C, for reference only
- CRI measurement tolerance: ±2.
- Each 1W white PN is based on the min. bin, and includes two adjacent bins.

PN of the Shwo(F) Super High Luminous Series: White LEDs

The table below is a list of part numbers for the Everlight Shwo(F) super high luminous series White LED. All parts listed match ANSI binning standards. Bin offerings of 6500K, 5700K, 5000K are listed and currently available. CRI is also listed with min 70 to 80. Typical view angle is 120°. These clearly listed binning options allow for proper design and implementation into lighting applications. The Order Codes below are currently available White Shwo(F) LEDs.

For Example: If you order product using P/N **ELSWF-J81C1-6FPGS-C5700**, you will be specifying:



Color Variant	Radiation Pattern	CRI	CCT	Forward Voltage (V)	Minimum Luminous Flux (lm)
Cool White	Lambertian	70	57K-1,57K-2, 57K-3,57K-4	2.65~2.95(U4) 2.95~3.25(V1)	170

White Shwo(F) series LEDs at 350mA are listed below @ 25°C.

Order Code of ELSWF	Minimum Luminous Flux (lm) @ Thermal Pad Temperature 85°C			Typ. Luminous Flux (lm) @ Thermal Pad Temperature 85°C			CCT (K) Wavelength (nm)	Forward Voltage (V)	CRI (Min.)
	350 mA	700 mA	1000 mA	350 mA	700 mA	1000 mA			
ELSWF-JJ1C1-6FPGS-C6500	158 (175)	283 (316)	378 (420)	169 (187)	304 (337)	406 (449)	65K-1~65K-4	2.65~3.25	70
ELSWF-J81C1-6FPGS-C6500	153 (170)	275 (307)	367 (408)	164 (182)	295 (328)	394 (437)	65K-1~65K-4	2.65~3.25	70
ELSWF-JJ1C1-6FPGS-C5700	158 (175)	283 (316)	378 (420)	169 (187)	304 (337)	406 (449)	57K-1~57K-4	2.65~3.25	70
ELSWF-J81C1-6FPGS-C5700	153 (170)	275 (307)	367 (408)	164 (182)	295 (328)	394 (437)	57K-1~57K-4	2.65~3.25	70
ELSWF-JJ1C1-6FPGS-C5000	158 (175)	283 (316)	378 (420)	169 (187)	304 (337)	406 (449)	50K-1~50K-4	2.65~3.25	70
ELSWF-J81C1-6FPGS-C5000	153 (170)	275 (307)	367 (408)	164 (182)	295 (328)	394 (437)	50K-1~50K-4	2.65~3.25	70
ELSWF-J71C1-6FPHS-C5000	145 (160)	260 (288)	345 (383)	155 (172)	278 (309)	371 (411)	50K-1~50K-4	2.65~3.25	80
ELSWF-J71N1-6FPGS-C4000	145 (160)	260 (288)	345 (383)	155 (172)	278 (309)	371 (411)	40K-1~40K-4	2.65~3.25	70
ELSWF-J51N1-6FPHS-C4000	126 (140)	234 (260)	318 (353)	140 (155)	258 (286)	350 (388)	40K-1~40K-4	2.65~3.25	80
ELSWF-J61M1-6FPGS-C3500	135 (150)	243 (270)	323 (359)	146 (162)	262 (291)	348 (387)	35K-1~35K-4	2.65~3.25	70
ELSWF-J61M1-6FPGS-C3000	135 (150)	243 (270)	323 (359)	146 (162)	262 (291)	348 (387)	30K-1~30K-4	2.65~3.25	70
ELSWF-J41M1-6FPHS-C3000	117 (130)	206 (229)	267 (296)	128 (142)	224 (249)	291 (323)	30K-1~30K-4	2.65~3.25	80

Order Code of ELSWF	Minimum Luminous Flux (lm) @ Thermal Pad Temperature 85°C			Typ. Luminous Flux (lm) @ Thermal Pad Temperature 85°C			CCT (K) Wavelength (nm)	Forward Voltage (V)	CRI (Min.)
	350 mA	700 mA	1000 mA	350 mA	700 mA	1000 mA			
ELSWF-J61M1-6FPGS-C2700	135 (150)	243 (270)	323 (359)	146 (162)	262 (291)	348 (387)	27K-1~27K-4	2.65~3.25	70
ELSWF-J41M1-6FPHS-C2700	117 (130)	206 (229)	267 (296)	128 (142)	224 (249)	291 (323)	27K-1~27K-4	2.65~3.25	80

Notes:

1. (value in bracket): Luminous flux @ 25°C, for reference only
2. CRI measurement tolerance: ±2.
3. Each 1W white PN is based on the min. bin, and includes two adjacent bins.

EVERLIGHT

PN of the Shwo(F) series: Color LEDs

The table below is a list of the binning options for the Everlight Shwo(F) 1W series Color LED.

Standard Everlight color bins are listed according to wavelength and represent the standard primary colors of the spectrum. Typical view angle is 120°. These clearly listed binning options allow for proper design and implementation into lighting applications. The Order Codes below are currently available Color Shwo(F) LEDs.

For Example: If you order product using P/N **ELSWF-R61L1-6FPNM-CB4B6**, you will be specifying:

Color	Order Code of ELSWF	Minimum Radiometric Power (mW)	Peak Wavelength (nm)	Forward Voltage(V)
Royal Blue	ELSWF-R61L1-6FPNM-CB4B6	600	445~460	2.65~3.25

Note: Each 1W direct color PN is based on the min. bin and includes four adjacent bins.

EVERLIGHT

Product Binning Luminous Flux Bins

Group	Bin	Minimum Photometric Flux (lm)	Maximum Photometric Flux (lm)
E	1	4	5
	2	5	6
	3	6	8
	4	8	10
	5	10	13
	6	13	17
	7	17	20
	8	20	23
	9	23	27
F	1	27	33
	2	33	39
	3	39	45
	4	45	52
	5	52	60
	6	60	70
	7	70	80
	8	80	90
	9	90	100
	A	65	75
	B	75	85
	C	85	95
	E	95	105

Group	Bin	Minimum Photometric Flux (lm)	Maximum Photometric Flux (lm)
J	1	100	110
	2	110	120
	3	120	130
	4	130	140
	5	140	150
	6	150	160
	7	160	170
	8	170	180
	9	180	190
	0	190	200
	A	105	115
	B	115	125
	C	125	135
	E	135	145
K	1	200	210
	2	210	220

Radiometric Power Bins

Group Bin	Minimum Radiometric Power(mW)	Maximum Radiometric Power(mW)
Q6Q7	125	225
Q7Q8	175	275
Q8Q9	225	330
Q9R1	275	380
R1R2	330	430
R2R3	380	480
R3R4	430	530
R4R5	480	600
R5R6	530	700
R6	600	700
R7	700	800
R8	800	900
R9S1	900	1100
S2S3	1100	1300
S4S5	1300	1500
S6S7	1500	1700
S8S9	1700	1900

EVERLIGHT

White Bin Structure

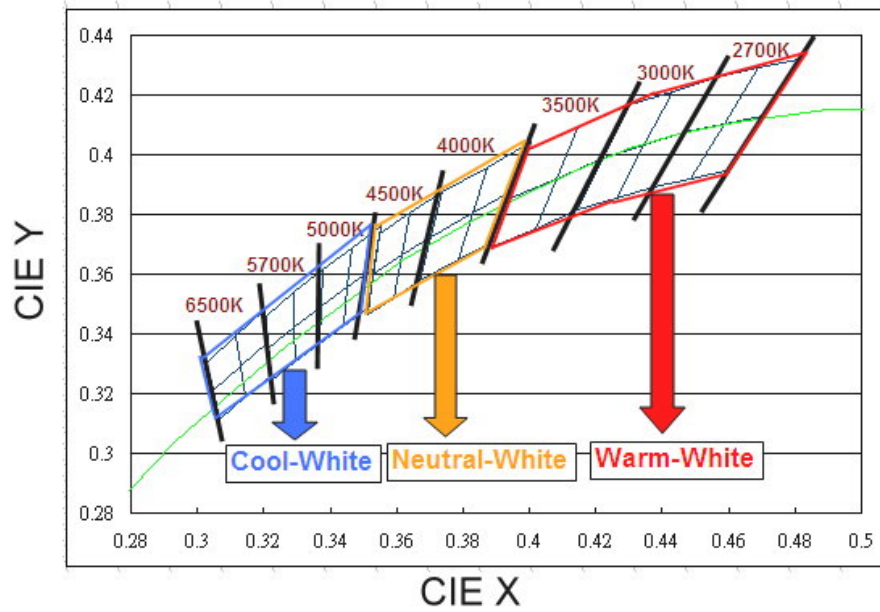

Chromaticity specification defined by ANSI

Notes:

1. The CCT range of Cool-White varies from 4745K to 7050K.
2. The CCT range of Neutral-White varies from 3710K to 4745K.
3. The CCT range of Warm-White varies from 2580K to 3710K
4. Color coordinates measurement allowance : ± 0.01
5. Color bins are defined at $I_f=350\text{mA}$ operation.

Cool-White Bin Structure

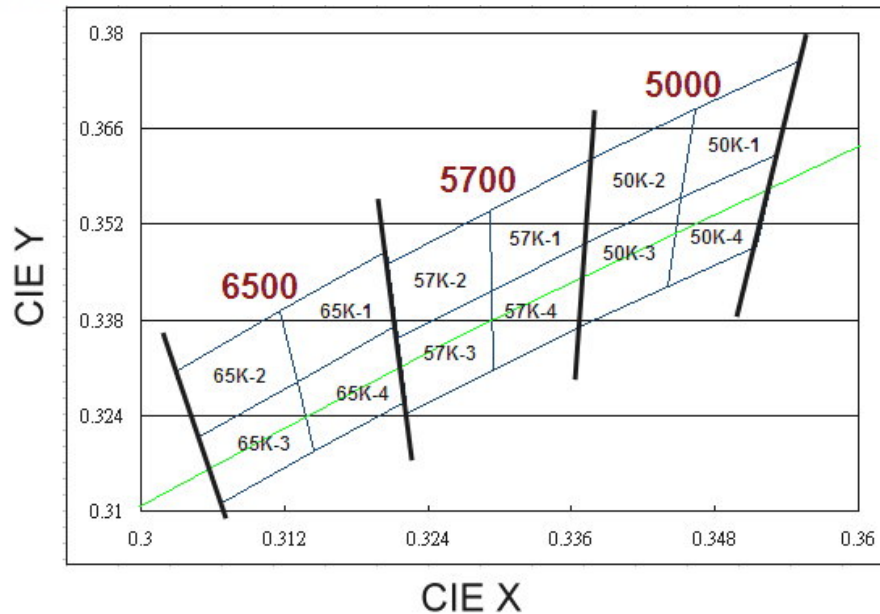

Cool-White Bin Coordinates

5000K

Bin	CIE X	CIE Y
50K-1	0.346	0.369
	0.345	0.356
	0.353	0.362
	0.355	0.376
Reference Range: 4745~5000K		

Bin	CIE X	CIE Y
50K-2	0.338	0.362
	0.337	0.349
	0.345	0.356
	0.346	0.369
Reference Range: 5000~5310K		

Bin	CIE X	CIE Y
50K-4	0.345	0.356
	0.344	0.343
	0.352	0.349
	0.353	0.362
Reference Range: 4745~5000K		

Bin	CIE X	CIE Y
50K-3	0.337	0.349
	0.337	0.337
	0.344	0.343
	0.345	0.356
Reference Range: 5000~5310K		

5700K

Bin	CIE X	CIE Y
57K-1	0.329	0.354
	0.329	0.342
	0.337	0.349
	0.338	0.362
Reference Range: 5310~5700K		

Bin	CIE X	CIE Y
57K-2	0.321	0.346
	0.321	0.335
	0.329	0.342
	0.329	0.354
Reference Range: 5700~6020K		

Bin	CIE X	CIE Y
57K-4	0.329	0.342
	0.329	0.331
	0.337	0.337
	0.337	0.349
Reference Range: 5310~5700K		

Bin	CIE X	CIE Y
57K-3	0.321	0.335
	0.322	0.324
	0.329	0.331
	0.329	0.342
Reference Range: 5700~6020K		

6500K

Bin	CIE X	CIE Y
65K-1	0.312	0.339
	0.313	0.329
	0.321	0.337
	0.321	0.348
Reference Range: 6020~6500K		

Bin	CIE X	CIE Y
65K-2	0.303	0.330
	0.305	0.321
	0.313	0.329
	0.312	0.339
Reference Range: 6500~7050K		

Bin	CIE X	CIE Y
65K-4	0.313	0.329
	0.315	0.319
	0.322	0.326
	0.321	0.337
Reference Range: 6020~6500K		

Bin	CIE X	CIE Y
65K-3	0.305	0.321
	0.307	0.311
	0.315	0.319
	0.313	0.329
Reference Range: 6500~7050K		

Neutral-White Bin Structure

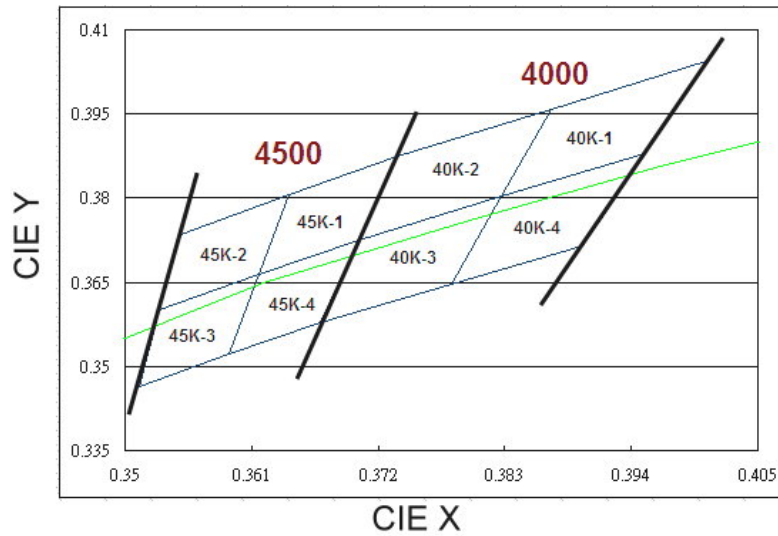

Neutral-White Bin Coordinates

4000K

Bin	CIE X	CIE Y
40K-1	0.387	0.396
	0.383	0.380
	0.395	0.388
	0.401	0.404
Reference Range: 3710~4000K		

Bin	CIE X	CIE Y
40K-2	0.374	0.387
	0.370	0.373
	0.383	0.380
	0.387	0.396
Reference Range: 4000~4260K		

Bin	CIE X	CIE Y
40K-4	0.383	0.380
	0.378	0.365
	0.390	0.372
	0.395	0.388
Reference Range: 3710~4000K		

Bin	CIE X	CIE Y
40K-3	0.370	0.373
	0.367	0.358
	0.378	0.365
	0.383	0.380
Reference Range: 4000~4260K		

4500K

Bin	CIE X	CIE Y
45K-1	0.364	0.381
	0.362	0.366
	0.370	0.373
	0.374	0.387
Reference Range: 4260~4500K		

Bin	CIE X	CIE Y
45K-2	0.355	0.374
	0.353	0.360
	0.362	0.366
	0.364	0.381
Reference Range: 4500~4745K		

Bin	CIE X	CIE Y
45K-4	0.362	0.366
	0.359	0.352
	0.367	0.358
	0.370	0.373
Reference Range: 4260~4500K		

Bin	CIE X	CIE Y
45K-3	0.353	0.360
	0.351	0.347
	0.359	0.352
	0.362	0.366
Reference Range: 4500~4745K		

Warm-White Bin Structure

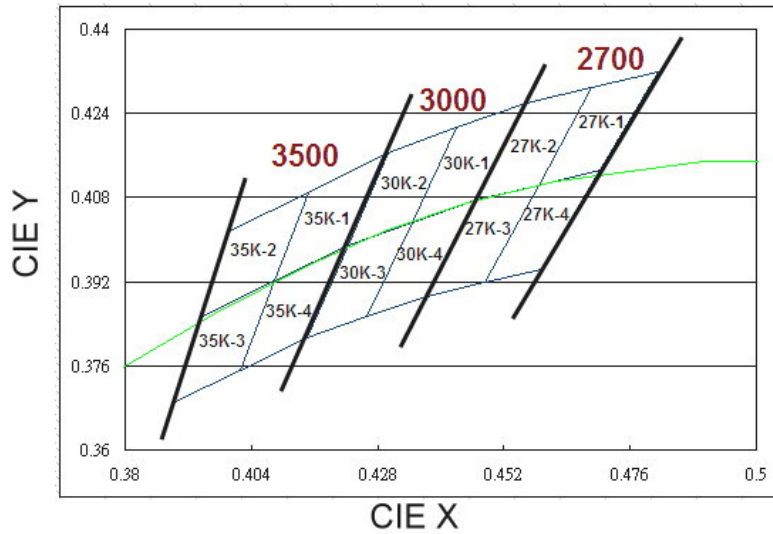

Warm-White Bin Coordinates

2700K

Bin	CIE X	CIE Y
27K-1	0.469	0.429
	0.459	0.410
	0.470	0.413
	0.481	0.432
Reference Range: 2580~2700K		

Bin	CIE X	CIE Y
27K-2	0.456	0.426
	0.447	0.408
	0.459	0.410
	0.469	0.429
Reference Range: 2700~2870K		

Bin	CIE X	CIE Y
27K-4	0.459	0.410
	0.448	0.392
	0.459	0.394
	0.470	0.413
Reference Range: 2580~2700K		

Bin	CIE X	CIE Y
27K-3	0.447	0.408
	0.437	0.389
	0.448	0.392
	0.459	0.410
Reference Range: 2700~2870K		

3000K

Bin	CIE X	CIE Y
30K-1	0.443	0.421
	0.435	0.403
	0.447	0.408
	0.456	0.426
Reference Range: 2870~3000K		

Bin	CIE X	CIE Y
30K-2	0.430	0.417
	0.422	0.399
	0.435	0.403
	0.443	0.421
Reference Range: 3000~3220K		

Bin	CIE X	CIE Y
30K-4	0.435	0.403
	0.426	0.385
	0.437	0.389
	0.447	0.408
Reference Range: 2870~3000K		

Bin	CIE X	CIE Y
30K-3	0.422	0.399
	0.415	0.381
	0.426	0.385
	0.435	0.403
Reference Range: 3000~3220K		

3500K

Bin	CIE X	CIE Y
35K-1	0.415	0.409
	0.408	0.392
	0.422	0.399
	0.430	0.417
Reference Range: 3220~3500K		

Bin	CIE X	CIE Y
35K-2	0.400	0.402
	0.394	0.385
	0.408	0.392
	0.415	0.409
Reference Range: 3500~3710K		

Bin	CIE X	CIE Y
35K-4	0.408	0.392
	0.402	0.375
	0.415	0.381
	0.422	0.399
Reference Range: 3220~3500K		

Bin	CIE X	CIE Y
35K-3	0.394	0.385
	0.389	0.369
	0.402	0.375
	0.408	0.392
Reference Range: 3500~3710K		

Color Bins

Group	Bin	Minimum Dominant Wavelength (nm)	Maximum Dominant Wavelength (nm)
B (Blue)	4	445	450
	5	450	455
	6	455	460

Forward Voltage Bins

Bin	Minimum Forward Voltage (V)	Maximum Forward Voltage (V)
U4	2.65	2.95

Notes:

1. Forward voltage measurement tolerance: $\pm 0.1V$.
2. Forward voltage bins are defined at $I_f=350mA$ operation.
3. Other Forward Voltage bins for White LEDs available upon request. Please contact your local Everlight sales office.

Optical Characteristics

Color	Part Number	Color Temperature CCT			Typical Viewing Angle (degrees) 20 _{1/2}
		Min.	Typ.	Max.	
Cool-White	ELSWF – XX1CX	4745K	5700K	7050K	120
Neutral-White	ELSWF – XX1NX	3710K	4260K	4745K	120
Warm-White	ELSWF– XX1MX	2580K	3000K	3710K	120

Notes:

1. The test tolerance of Everlight is $\pm 0.5nm$ for dominant wavelength, $\pm 5\%$ for CCT.
2. Viewing angle is the width of half the light output intensity in all directions of 180°.

Mechanical Dimension

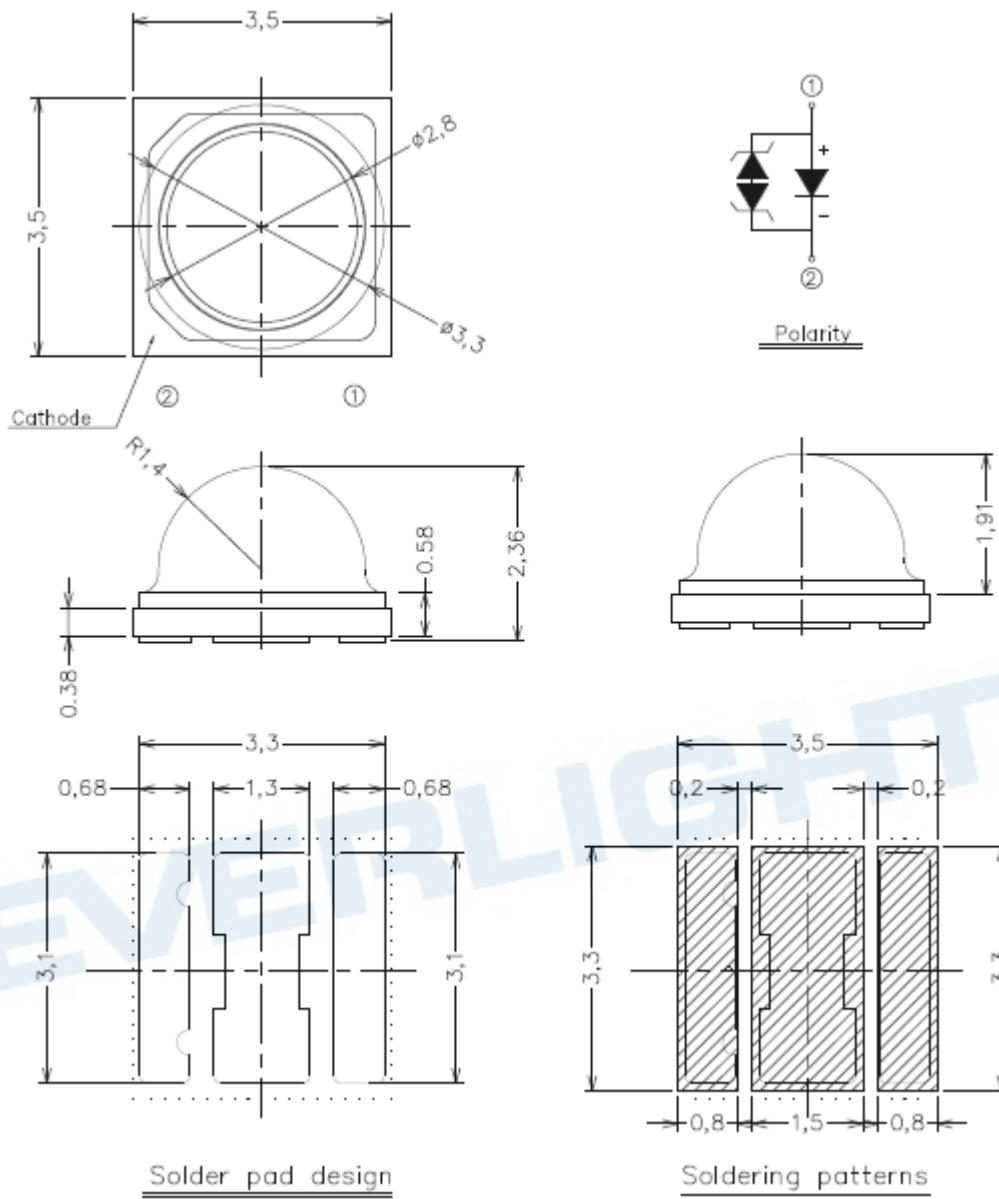

Notes:

1. Dimensions are in millimeters.
2. Tolerances unless mentioned are ± 0.15 mm.
3. The thermal pad is electrically isolated from the Anode and Cathode contact pads.
4. Do not handle the device by the lens. Incorrect force applied to the lens may lead to the failure of devices.

Pad Configuration

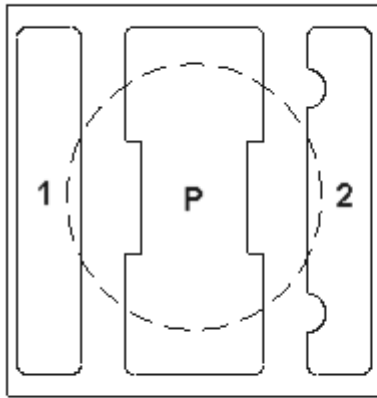

BOTTOM VIEW

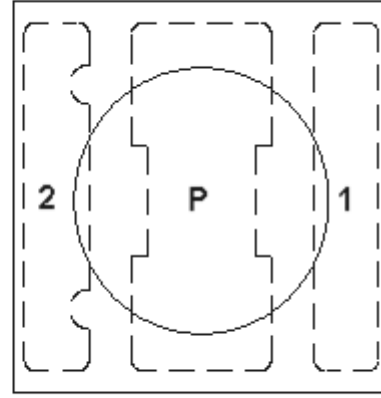

TOP VIEW

PAD	FUNCTION
1	ANODE
2	CATHODE
P	THERMAL PAD

Wavelength Characteristics

Cool-White @ Thermal Pad Temperature = 25°C

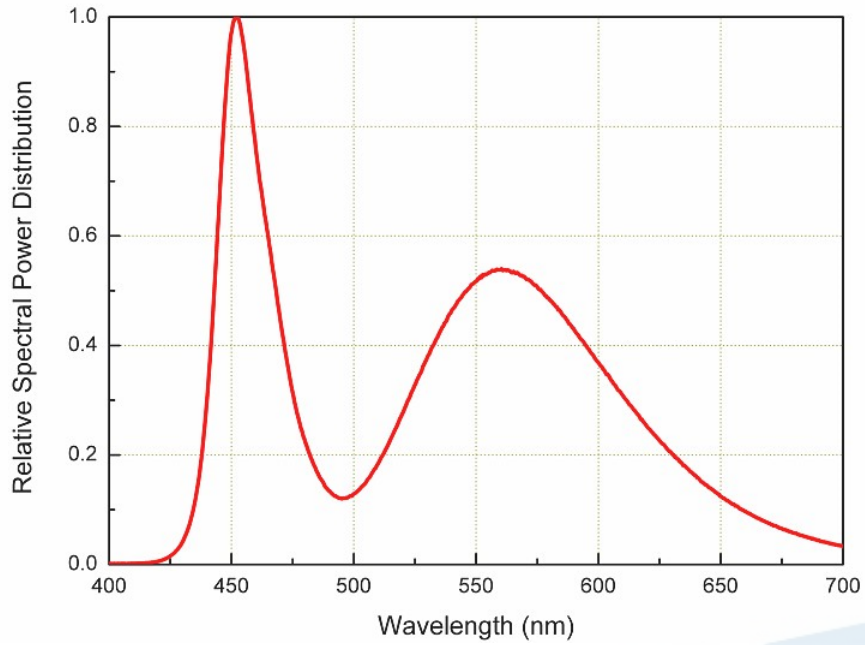

For Warm-White, @ Thermal Pad Temperature = 25°C

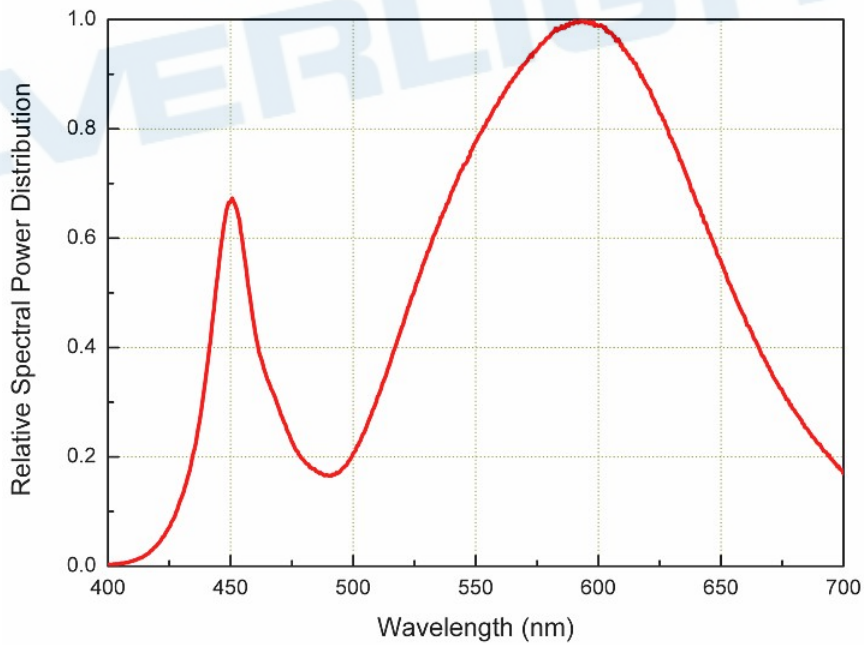

Typical Light Output Characteristic V.S. Thermal Pad Temperature

Cool-White, Warm-White for 350mA Drive Current

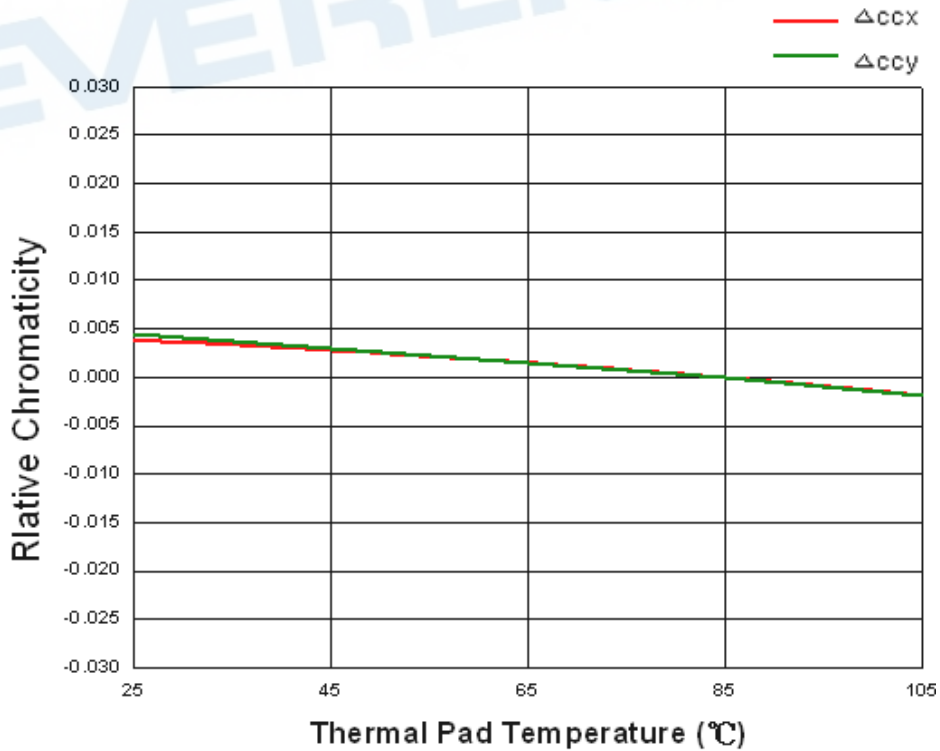
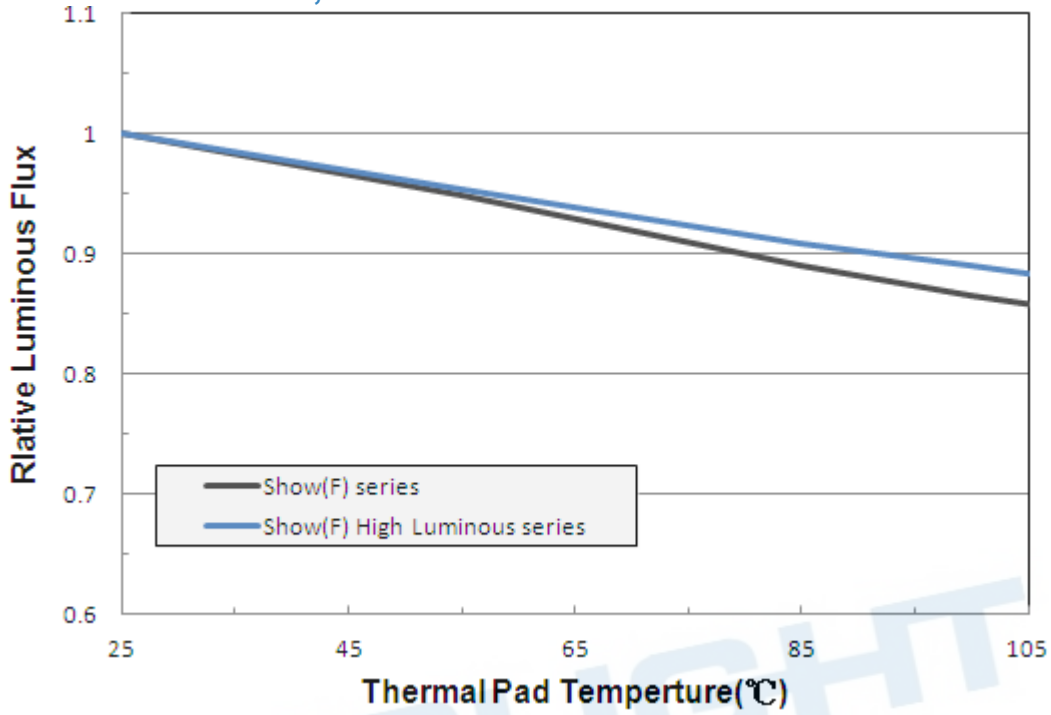

Typical Relative Luminous Flux V.S. Forward Current

Cool-White, Warm-White Thermal Pad Temperature = 25°C

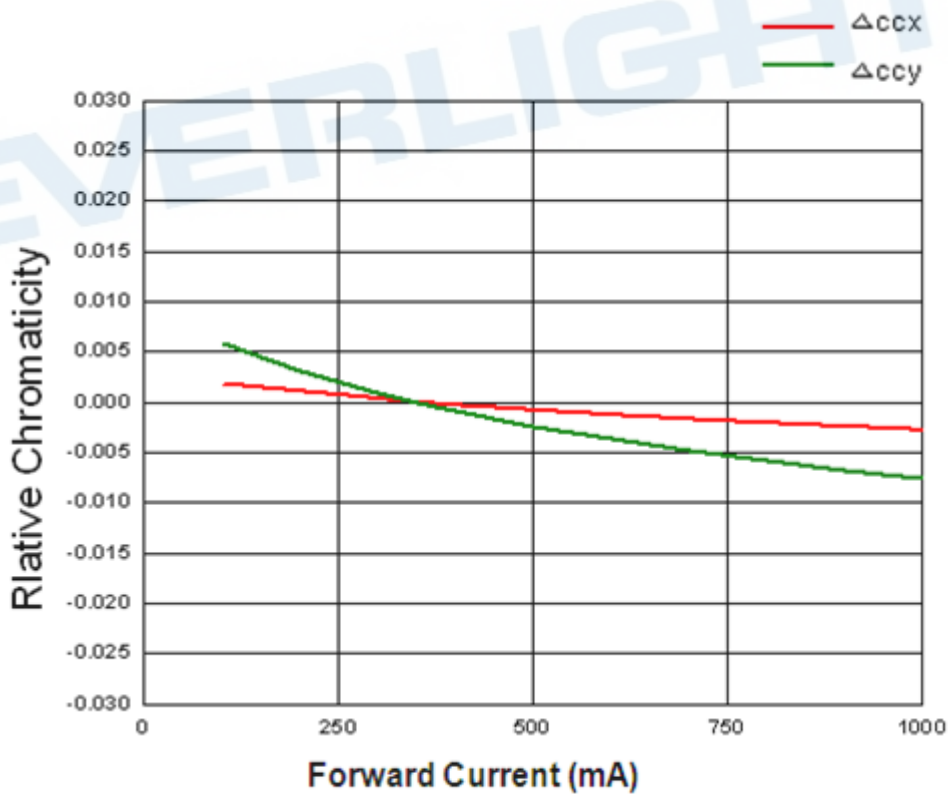
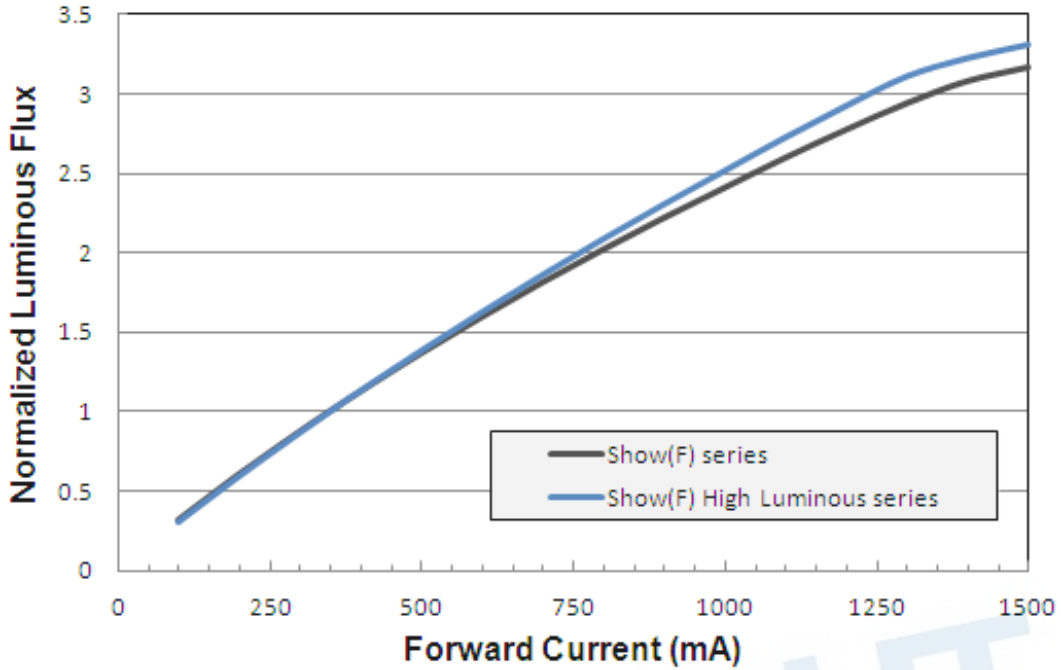

Typical Relative Luminous Flux V.S. Forward Current

Cool-White, Warm-White Thermal Pad Temperature = 25°C

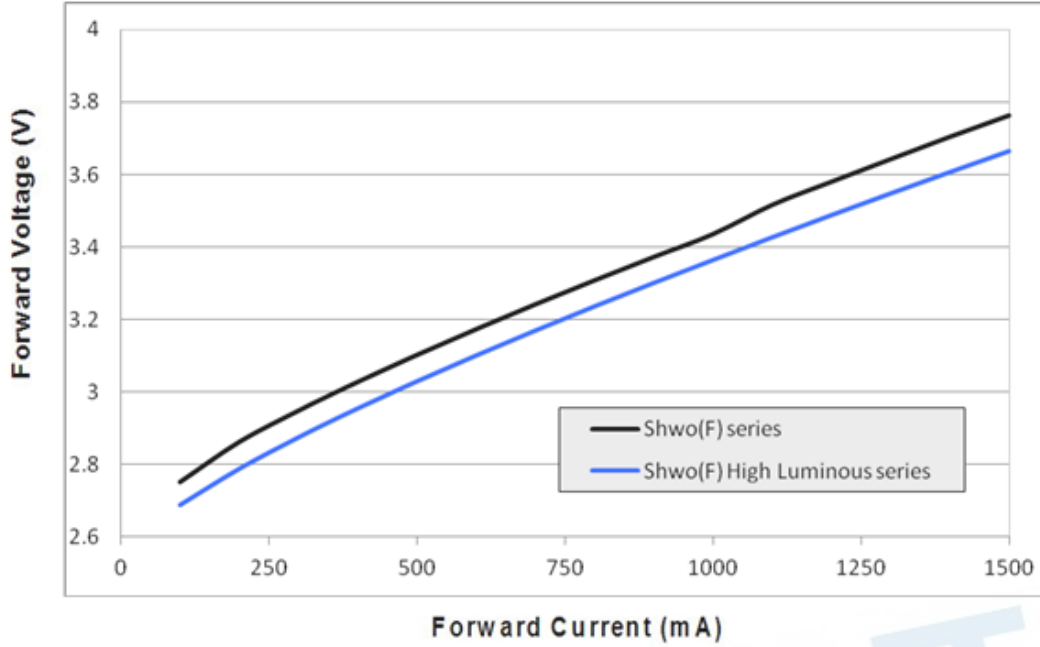

EVERLIGHT

Current Derating Curves (For Shwo(F) series)

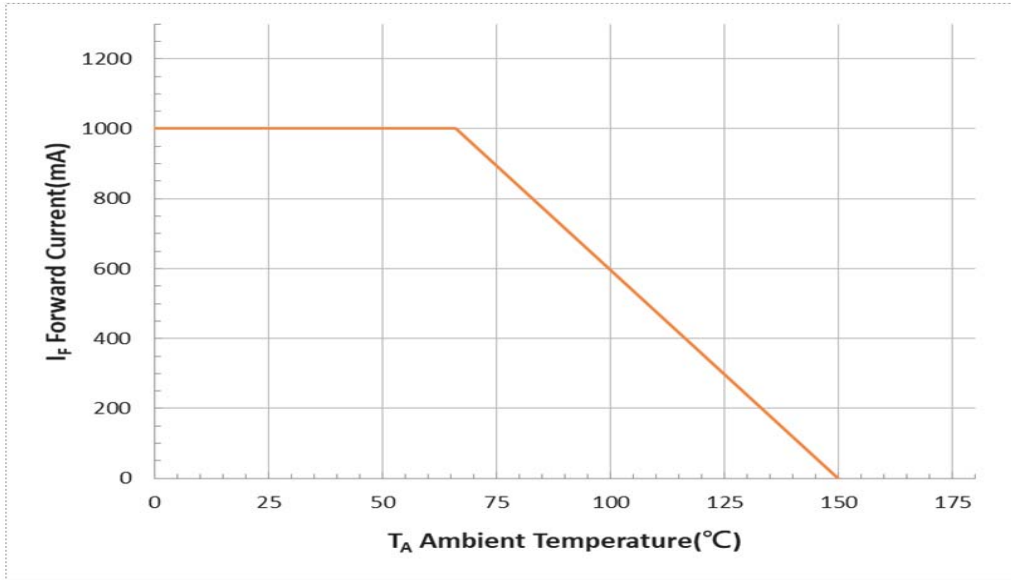

Current Derating Curves (For Shwo(F) High Luminous series)

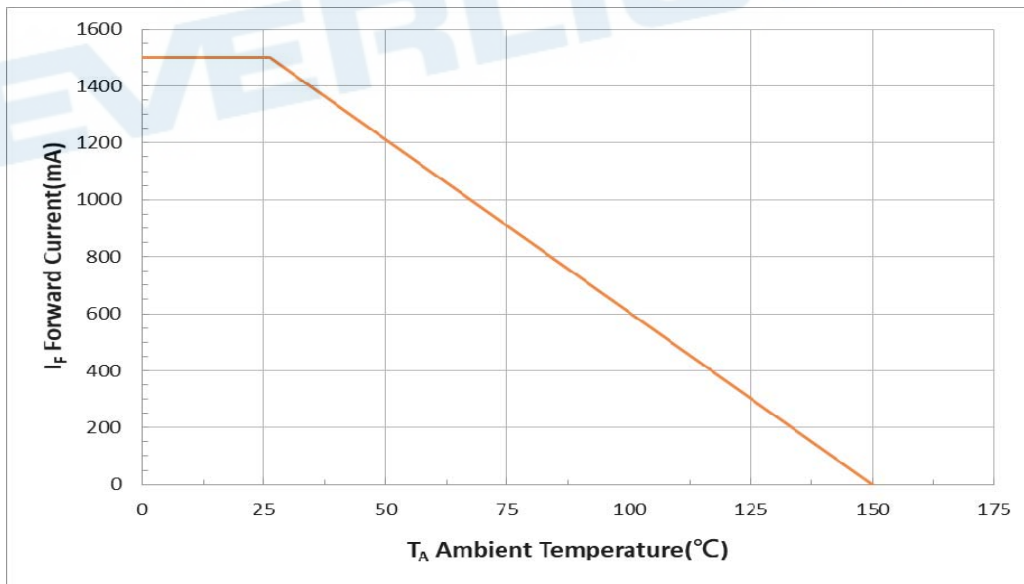

Note:

The current derating curves are depending on the thermal resistance between the junction to the Ambient Temperature.

Typical Radiation Patterns

Shwo(F) series:
Typical Diagram Characteristics of Radiation

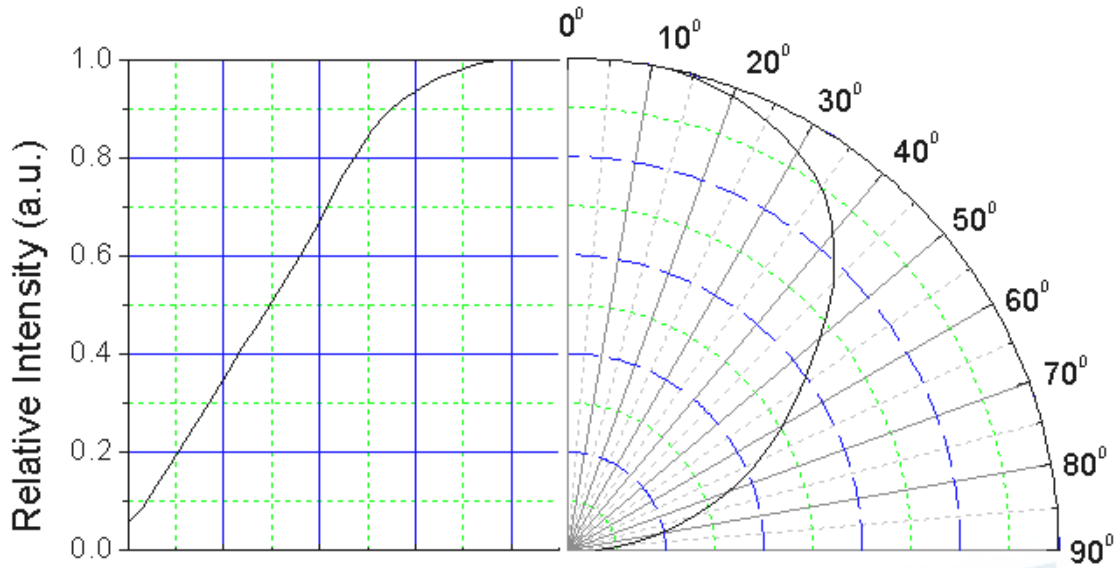

Notes:

1. $2\theta_{1/2}$ is the off axis angle from lamp centerline where the luminous intensity is 1/2 of the peak value.
2. View angle tolerance is $\pm 5^\circ$.

Emitter Reel Packaging

Reel Dimensions

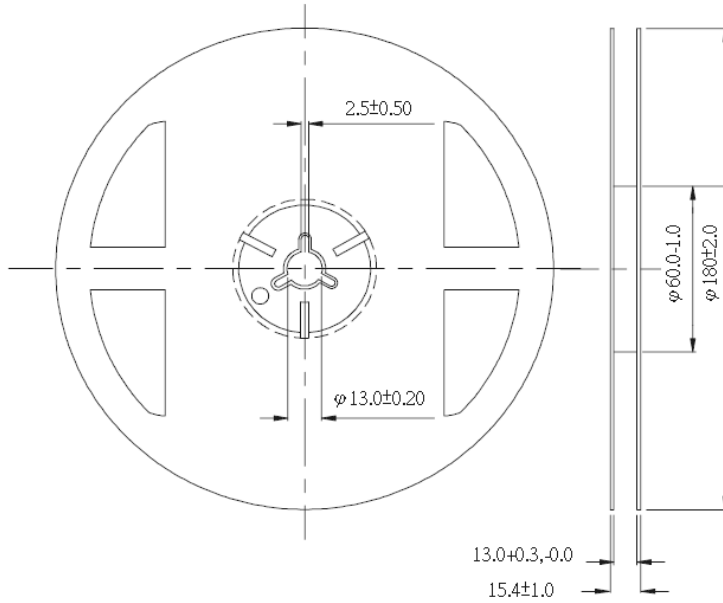

Notes:

1. Dimensions are in millimeters.
2. Tolerances unless mentioned are ± 0.1 mm.

Product Labeling

Label Explanation

CPN: Customer Specification (when required)

P/N : Everlight Production Number

QTY: Packing Quantity

CAT: Luminous Flux (Brightness) Bin

HUE: Color Bin

REF: Forward Voltage Bin

LOT No: Lot Number

MADE IN TAIWAN: Production Place

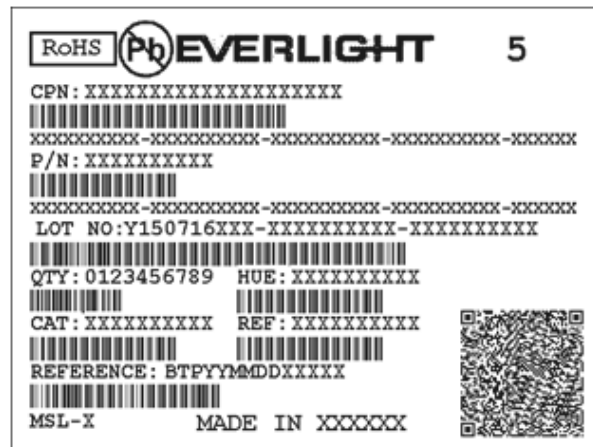

Reliability Data

Stress Test	Stress Condition	Stress Duration
Reflow	Tsol=260°C, 10sec	3 times
Thermal Shock	H : +100°C 20min. ┆ 10sec. 'L : -10°C 20min.	1000 Cycles
Temperature Cycle	H : +100°C 30min. ┆ 5min. 'L : -40°C 30min.	1000 Cycles
Room Temperature Operation Life	Ta=25°C, IF=1500mA	1000hours
High Temperature Operation Life #1	Ta=55°C, IF=1100mA	1000hours
High Temperature Operation Life #2	Ta=85°C, IF=780mA	1000hours
Low Temperature Operation Life	Ta=-40°C, IF=1500mA	1000hours

Failure Criteria:

1. LEDs are open or shorted
2. Im: luminous flux attenuate difference(1000hrs)>30%
3. VF: forward voltage difference(1000hrs)>20%
4. CCT: Color coordinates measurement allowance (1000hrs) >±0.02

Storage Conditions

- Recommended to operate in accordance with the following conditions, increased LED life.
- Before the package is opened. The LEDs should be stored at 30°C or less and 85%RH or less after being shipped from Everlight and the storage life limits are 1 year. The LEDs can be stored up to 3 years If in a sealed container with a nitrogen atmosphere and moisture absorbent material.
- After opening the package: The LED's floor life is 1 year under 30°C or less and 60%RH or less. The LED should be soldered with 168hrs (7days) after opening the package. If unused LEDs remain, it should be stored in moisture proof packages.
- If the moisture absorbent material (silica gel) has faded away or the LEDs have exceeded the storage time, baking treatment should be performed using the following conditions. Baking treatment: 60±5°C for 24 hours.

Thermal Management

- Recommended to operate in accordance with the following conditions, increased LED life.
- For maintaining the high flux output and achieving maximum reliability, EHP-C19 flashlight series LEDs should be mounted on a metal core printed circuit board (MCPCB) or other kinds of heat sink with proper thermal connection to dissipate approximately 1W of thermal energy at 350mA operation.
- Sufficient thermal management must be implemented. Please refer to the graph "Forward Current Derating Curve" on Page 20. The soldering temperature must be kept under 60°C at the driving current 350mA. Otherwise, the junction temperature of die may exceed over the limit at high current driving conditions and the LEDs' lifetime may be decrease dramatically.
- Special thermal designs are also recommended to take in outer heat sink design, such as FR4 PCB on Aluminum with thermal vias or FPC on Aluminum with thermal conductive adhesive, etc.
- Sufficient thermal management must be conducted, or the die junction temperature will be over the limit under large electronic driving and LED lifetime will decrease critically.

DISCLAIMER

1. EVERLIGHT reserves the right(s) on the adjustment of product material mix for the specification.
2. The product meets EVERLIGHT published specification for a period of twelve (12) months from date of shipment.
3. The graphs shown in this datasheet are representing typical data only and do not show guaranteed values.
4. When using this product, please observe the absolute maximum ratings and the instructions for using outlined in these specification sheets. EVERLIGHT assumes no responsibility for any damage resulting from the use of the product which does not comply with the absolute maximum ratings and the instructions included in these specification sheets.
5. These specification sheets include materials protected under copyright of EVERLIGHT. Reproduction in any form is prohibited without obtaining EVERLIGHT's prior consent.
6. This product is not intended to be used for military,aircraft,automotive,medical.

EVERLIGHT

Revision History

Current version: 2024/08/20
Device No: DHE-0002868
Version. 18

Page	Subjects (major change in previous version)	Date of change
10、22	Add Neutral-White Bin Structure & Modify Product Label	2016/2/1
8	Add High Luminous Series	2016/4/1
9	Modify Luminous Flux Bins	2016/5/4
13	Modify 2700K & 3000K CIE data & add 3500K CIE	2016/7/25
28	Add DS disclaimer	2016/12/08
9、10	Add New P/N.	2017/12/11
4、5、9、11	Modify New P/N.& Product Binning	2018/01/09
5、6、9、11	Modify New P/N.& Product Binning	2018/02/08
5、6、9、10	Modify Super High Luminous Series	2018/06/01
9	Modify Luminous Flux Bins	2018/06/26
9	Modify Luminous Flux Bins	2018/08/06
9、10、18	Modify Forward Voltage Bins & Modify Luminous Flux Bins	2018/09/13
11、12、13	Modify Super High Luminous Series VF Spec.	2019/06/03
27	Add Typical Relative Luminous Flux V.S. Forward Current	2019/06/03
15	Modify Radiometric Power Bins	2019/08/28
27	Modify the x-axis coordinates	2020/06/18
29	Modify Current Derating Curves	2023/01/03
20	Add Color Bins	2023/03/09
10、21	Modify Vf 2.65~2.95 & Removal of BINs except U4	2024/08/20