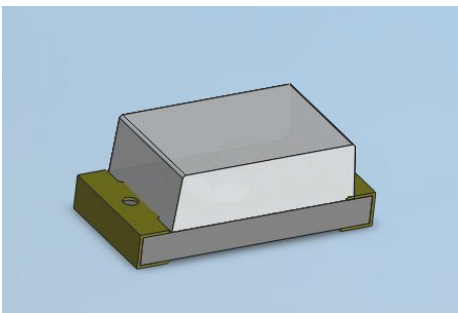

## SMD ■ B

## 19-213-R7C-A0R1S2B0C-3T-AM

**Features**

- RoHS compliant
- Chip LED package.
- Colorless clear resin.
- Wide viewing angle 120°
- Brightness:112.0 to 280.0mcd at 10mA.
- Qualification according to AEC-Q101.
- Precondition: Bases on JEDEC J-STD 020 Level 3.
- Automotive reflow profile (IR reflow or wave soldering)
- Compliance with EU REACH
- Compliance Halogen Free .(Br <900 ppm ,Cl <900 ppm , Br+Cl < 1500 ppm).

**Applications**

- Automotive backlighting or indicator: Dashboard, switch, audio and video equipments...etc.
- Backlight: LCD, switches, symbol, mobile phone and illuminated advertising.
- Display for indoor and outdoor application.
- Ideal for coupling into light guides.
- Substitution of traditional light.
- Optical indicator.
- General applications.

## Device Selection Guide

Chip Materials	Emitted Color	Resin Color
AlGaInP	Dark Red	Water Clear

## Absolute Maximum Ratings (Ta=25°C)

Parameter	Symbol	Rating	Unit
Reverse Voltage	$V_R$	12	V
Forward Current	$I_F$	30	mA
Peak Forward Current (Duty 1/10 @1KHz)	$I_{FP}$	60	mA
Power Dissipation	$P_d$	70.5	mW
Junction Temperature	$T_j$	125	°C
Operating Temperature	$T_{opr}$	-40 ~ +100	°C
Storage Temperature	$T_{stg}$	-40 ~ +110	°C
Thermal Resistance	$R_{th\ J-A}$	800	K/W
	$R_{th\ J-S}$	450	K/W
ESD (Classification acc. AEC Q101)	$ESD_{HBM}$	2000	V
	$ESD_{MM}$	200	V
Soldering Temperature	$T_{sol}$	Reflow Soldering : 260 °C for 30 sec.	
		Hand Soldering : 350 °C for 3 sec.	

## Electro-Optical Characteristics (Ta=25°C)

Parameter	Symbol	Min.	Typ.	Max.	Unit	Condition
Luminous Intensity	$I_v$	112.0	-----	280.0	mcd	$I_F=10mA$
Viewing Angle	$2\theta_{1/2}$	-----	120	-----	deg	
Peak Wavelength	$\lambda_p$	-----	639	-----	nm	
Dominant Wavelength	$\lambda_d$	625.5	----	637.5	nm	
Spectrum Radiation Bandwidth	$\Delta\lambda$	-----	20	-----	nm	
Forward Voltage	$V_F$	1.75	----	2.35	V	$V_R=12V$
Reverse Current	$I_R$	-----	-----	10	μA	
Temperature coefficient of $\lambda_p$	$TC_{\lambda_p}$	-----	0.13	-----	nm/K	$I_F=10mA$
Temperature coefficient of $\lambda_d$	$TC_{\lambda_d}$	-----	0.08	-----	nm/K	
Temperature coefficient of $V_F$	$TC_V$	-----	-4.3	-----	mV/K	

### Note:

1. Tolerance of Luminous Intensity: ±11%
2. Tolerance of Dominant Wavelength: ±1nm
3. Tolerance of Forward Voltage: ±0.05V
4. Reverse Voltage(VR) Condition is applied to IR test only The device is not designed for reverse operation

### Bin Range of Luminous Intensity

Bin Code	Min.	Max.	Unit	Condition
R1	112.0	140.0	mcd	I <sub>F</sub> =10mA
R2	140.0	180.0		
S1	180.0	224.0		
S2	224.0	280.0		

Note:  
 Tolerance of Luminous Intensity: ±11%

### Bin Range of Dominant Wavelength

Bin Code	Min.	Max.	Unit	Condition
E6	625.5	629.5	nm	I <sub>F</sub> =10mA
E7	629.5	633.5		
E8	633.5	637.5		

Note:  
 Tolerance of Dominant Wavelength: ±1nm

### Typical Electro-Optical Characteristics Curves

#### Typical Curve of Spectral Distribution

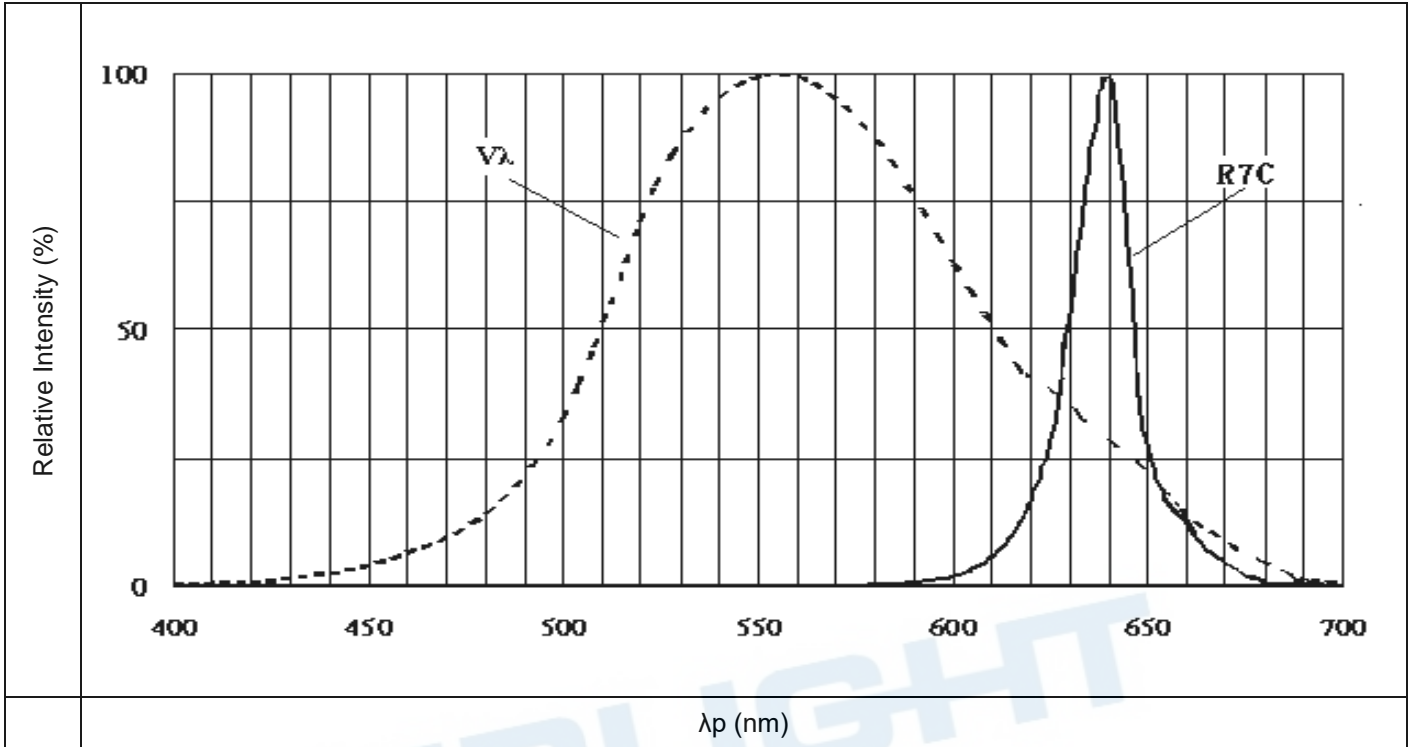

Note:  $V(\lambda)$ =Standard eye response curve;  $I_f = 20\text{mA}$

#### Diagram Characteristics of Radiation

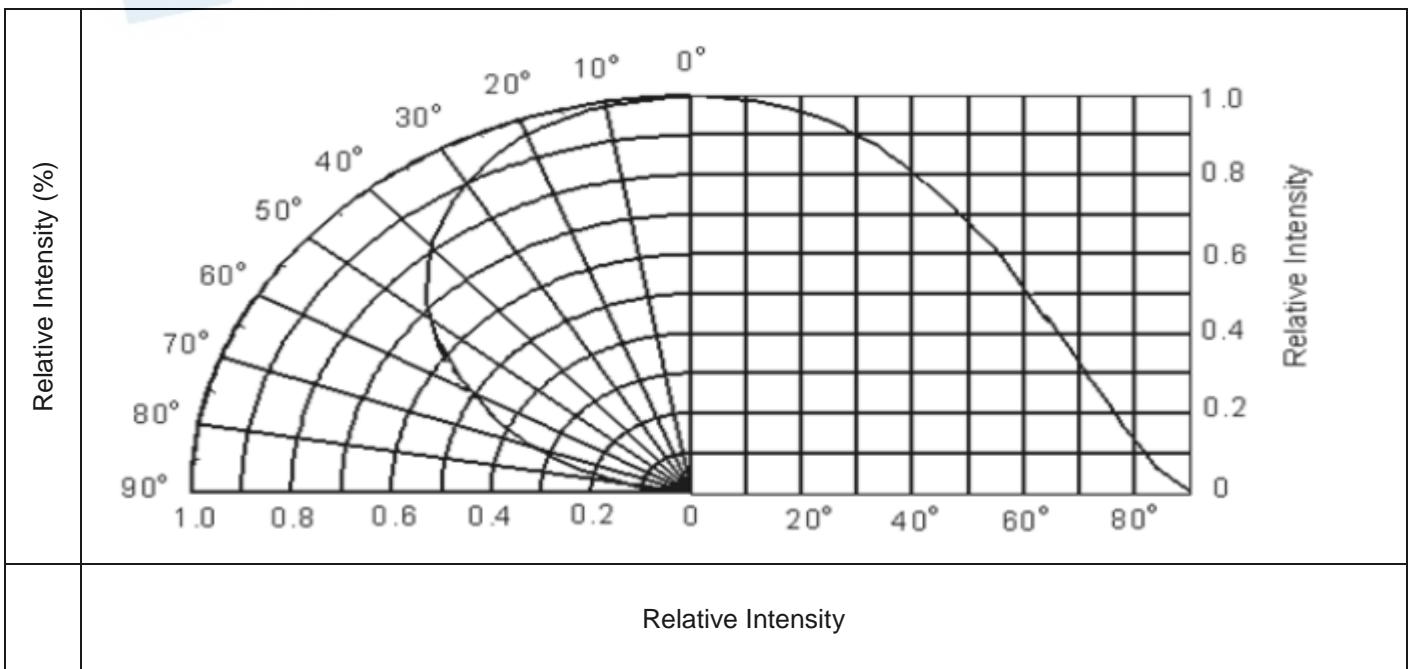

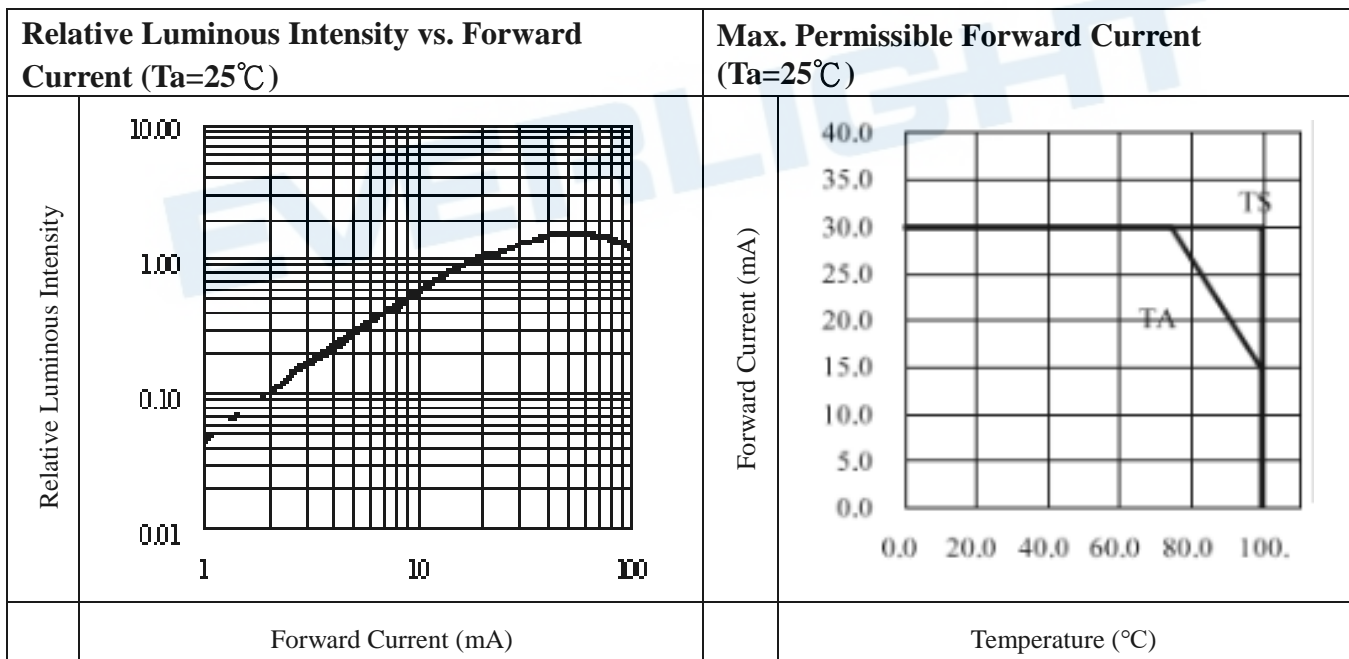
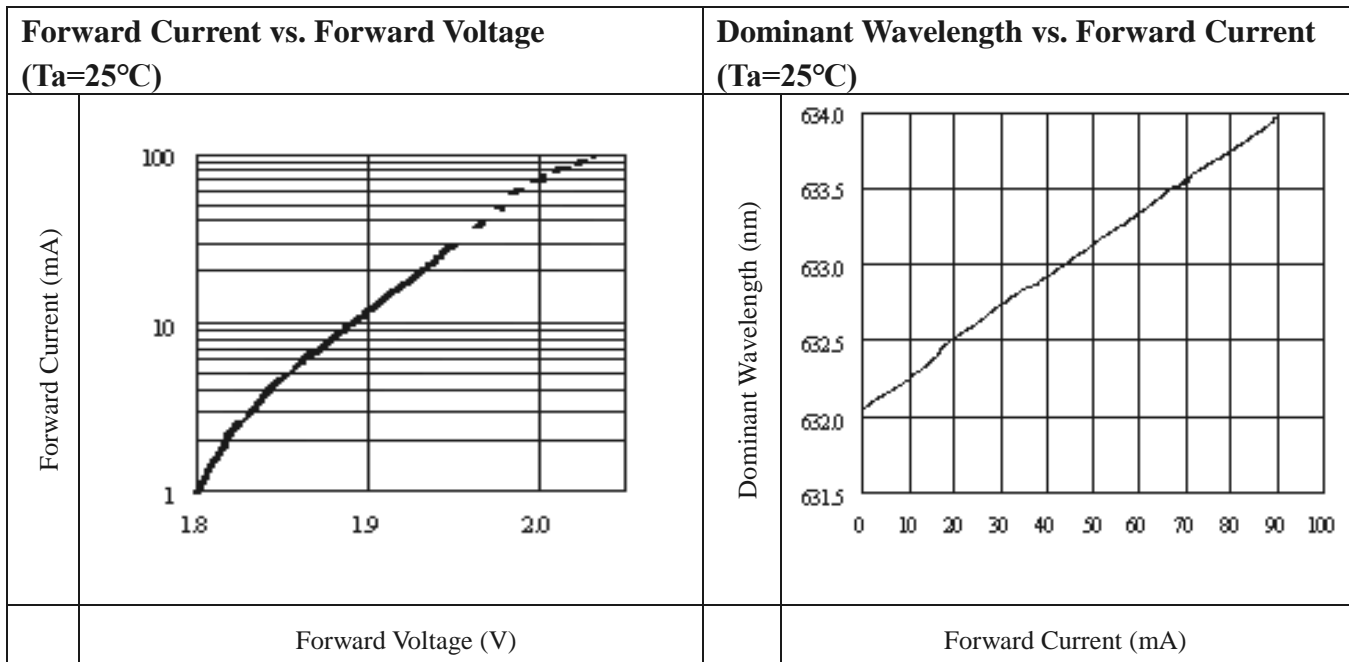

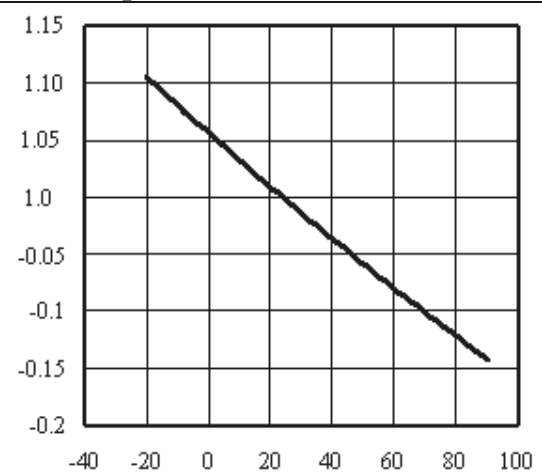
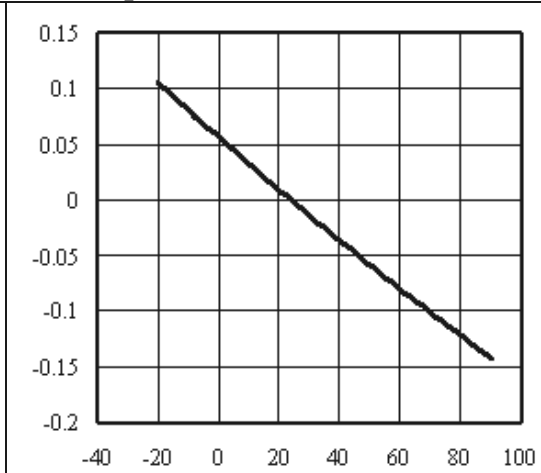
Relative Luminous Intensity vs. Junction Temperature		Relative Forward Voltage vs. Junction Temperature	
Relative Luminous Intensity		Relative Forward Voltage	
	Junction Temperature (°C)		Junction Temperature (°C)
Note: $f(T_j) = I_v / I_v(25^\circ\text{C}); I_F = 10\text{mA}$		Note: $\Delta V_F = V_F - V_F(25^\circ\text{C}) = f(T_j); I_F = 10\text{mA}$	

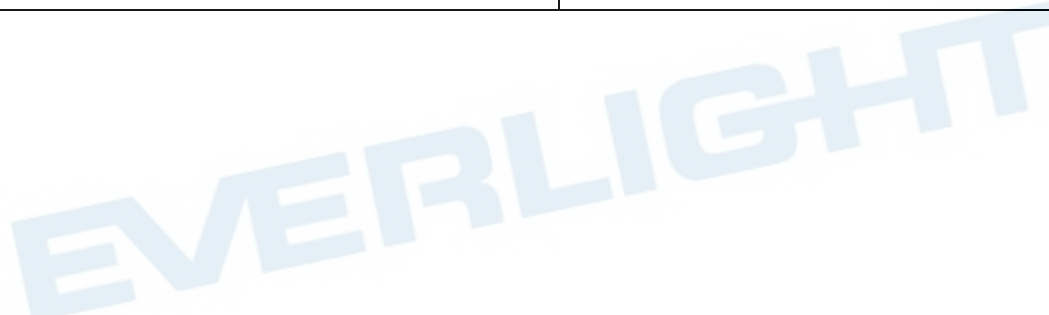

### Package Dimension

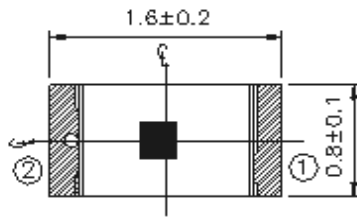

Top



Polarity

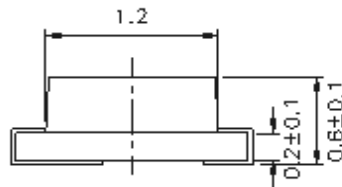

Side

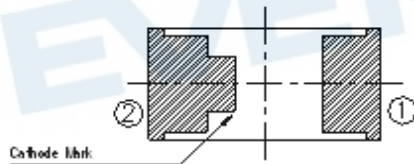

Bottom

Recommend Soldering Pad

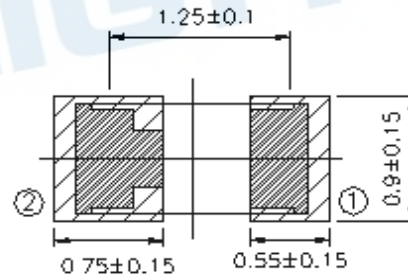

Suggested pad dimension is just for reference only.  
Please modify the pad dimension based on individual need.

Note: Tolerances unless mentioned  $\pm 0.1$ mm. Unit = mm

Moisture Resistant Packing Materials

Label Explanation



Label Explanation

- .CPN: Customer's Product Number
- .P/N: Product Number
- .QTY: Packing Quantity
- .CAT: Luminous Intensity Rank
- .HUE: Dom. Wavelength Rank
- .REF: Forward Voltage Rank
- .LOT No: Lot Number

Reel Dimensions

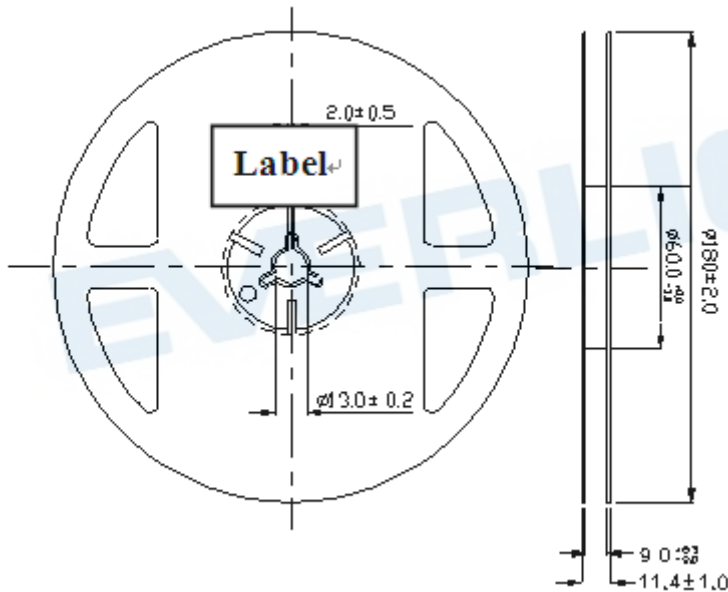

**Note:** The tolerances unless mentioned is  $\pm 0.1\text{mm}$ , Unit = mm

**Carrier Tape Dimensions: Loaded Quantity 3000 pcs Per Reel**

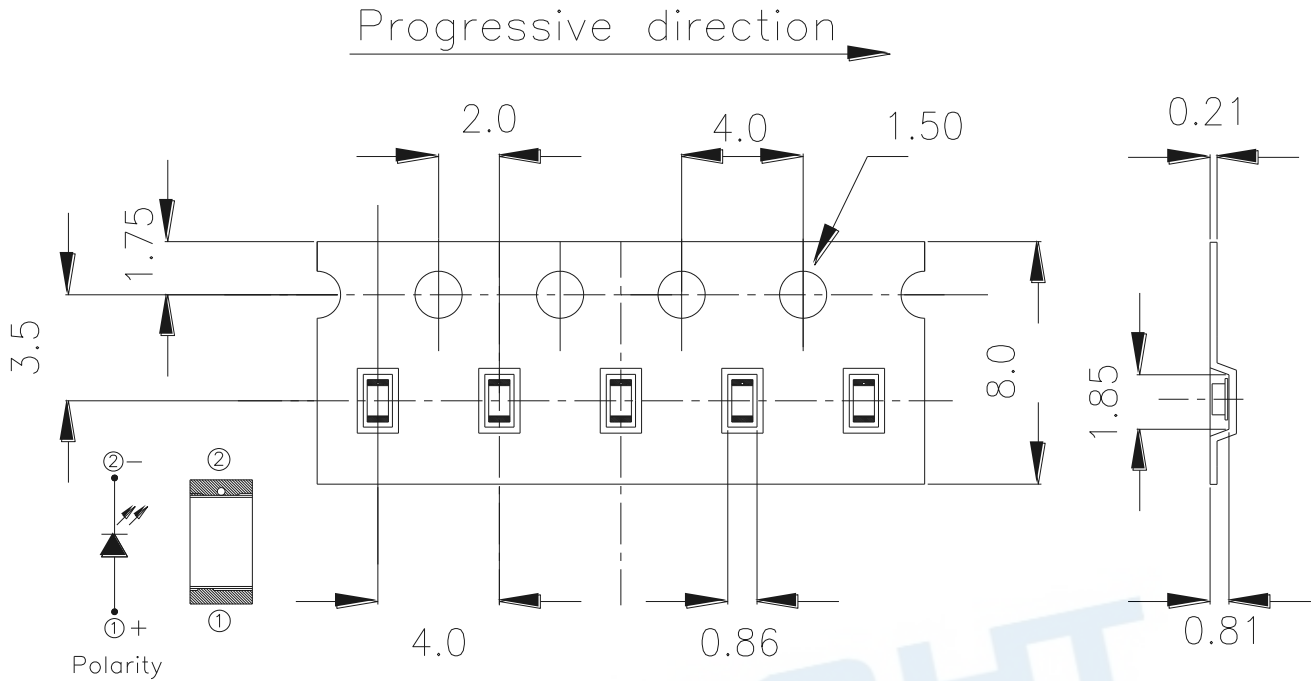

Note: Tolerances unless mentioned  $\pm 0.1\text{mm}$ . Unit = mm

**Moisture Resistant Packing Process**

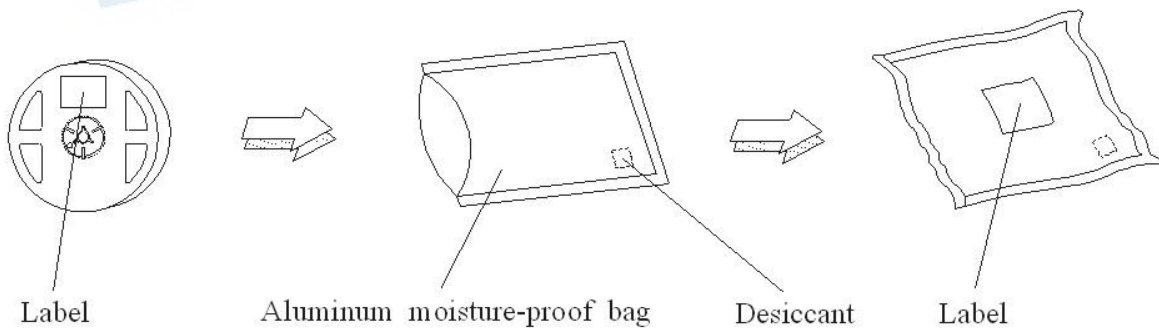

Note: Tolerances unless mentioned  $\pm 0.1\text{mm}$ . Unit = mm

## Precautions for Use

### 1. Soldering Condition (Reference: IPC/JEDEC J-STD-020D)

#### a. IR reflow

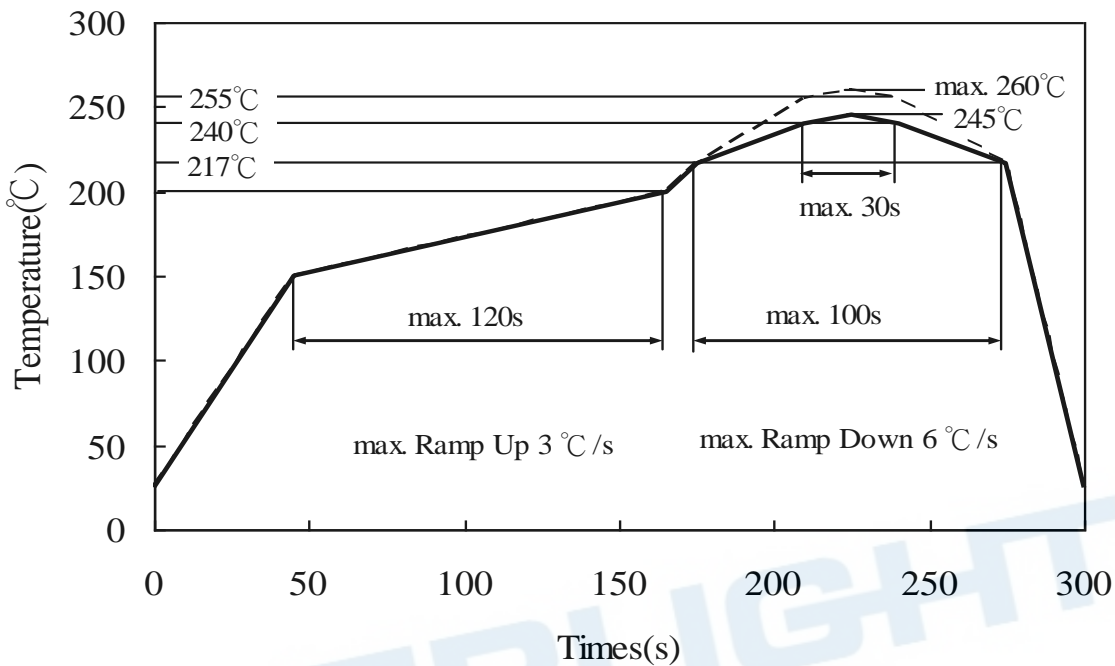

#### (B) Recommend soldering pad

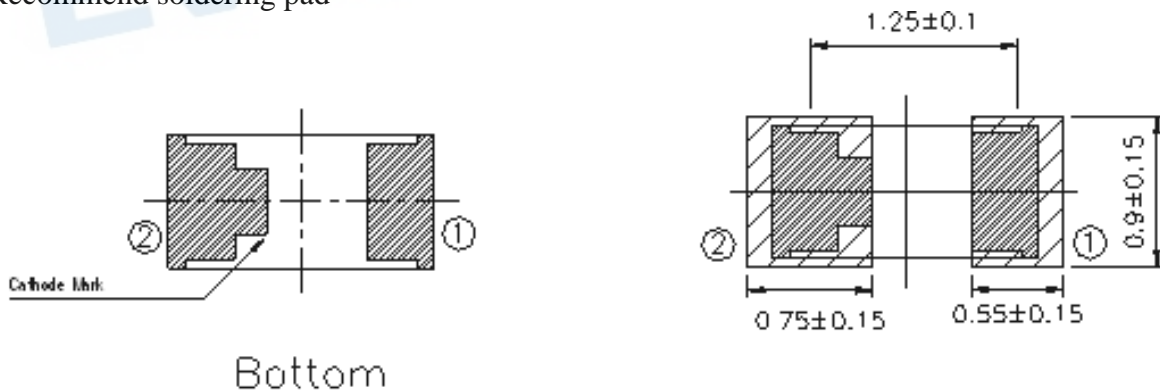

Bottom

Note: Tolerances unless mentioned  $\pm 0.1$ mm. Unit = mm

### 2. Current limiting

A resistor should be used to limit current spikes that can be caused by voltage fluctuations. Otherwise damage could occur.

### 3. Storage

3.1 Moisture proof bag should only be opened immediately prior to usage.

3.2 Environment should be less than 30°C and 60% RH when moisture proof bag is opened.

3.3 After opening the package MSL Conditions stated on page 1 of this spec should not be exceeded.

3.4 If the moisture sensitivity card indicates higher than acceptable moisture, the component should be baked at min. 60deg +/-5deg for 24 hours.

#### 4. Iron Soldering

Hand soldering is not recommended for regular production. These guidelines are for rework only. Soldering iron tip should contact each terminal no more than 3 sec at 350°C, using soldering iron with nominal power less than 25W. Allow min. 2 sec. between soldering intervals.

#### 5. Usage

Do not exceed the values given in this specification.

### Application Restrictions

1. High reliability applications such as military/aerospace, automotive safety/security systems, and medical equipment may require different product. If you have any concerns, please contact Everlight before using this product in your application. This specification guarantees the quality and performance of the product as an individual component. Do not use this product beyond the specification described in this document.

### Revision History:

Rev.	Modified date	File modified contents
1	2010/7/22	New Spec
2	2015/7/10	Reject
3	2021/3/26	Release
4		
5		