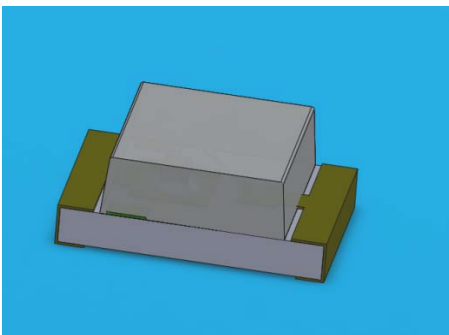

## SMD ■ B

## 17-215-GPC-R7L1M2L0E-3T-AM

**Features**

- RoHS compliant
- Chip LED package.
- Colorless clear resin.
- Wide viewing angle 130°.
- Brightness:11.20 to 28.00 mcd at 20mA.
- Qualification according to AEC-Q101.
- Precondition: Bases on JEDEC J-STD 020 Level 3.
- Automotive reflow profile (IR reflow or wave soldering)

**Applications**

- Automotive backlighting or indicator: Dashboard, switch, audio and video equipments...etc.
- Backlight: LCD, switches, symbol, mobile phone and illuminated advertising.
- Display for indoor and outdoor application.
- Ideal for coupling into light guides.
- Substitution of traditional light.
- Optical indicator.
- General applications.

## Device Selection Guide

Chip Materials	Emitted Color	Resin Color
AlGaInP	Pure Green	Water Clear

## Absolute Maximum Ratings (Ta=25°C)

Parameter	Symbol	Rating	Unit
Reverse Voltage	$V_R$	12	V
Forward Current	$I_F$	30	mA
Peak Forward Current (Duty 1/10 @1KHz)	$I_{FP}$	60	mA
Power Dissipation	$P_d$	60	mW
Junction Temperature	$T_j$	125	°C
Operating Temperature	$T_{opr}$	-40 ~ +100	°C
Storage Temperature	$T_{stg}$	-40 ~ +110	°C
Thermal Resistance	$R_{th\ J-A}$	800	K/W
	$R_{th\ J-S}$	450	K/W
ESD (Classification acc. AEC Q101)	$ESD_{HBM}$	2000	V
	$ESD_{MM}$	200	V
Soldering Temperature	$T_{sol}$	Reflow Soldering : 260 °C for 30 sec. Hand Soldering : 350 °C for 3 sec.	

Reverse Voltage(VR) Condition is applied to IR test only The device is not designed for reverse operation

## Electro-Optical Characteristics (Ta=25°C)

Parameter	Symbol	Min.	Typ.	Max.	Unit	Condition
Luminous Intensity	I <sub>v</sub>	11.20	-----	28.00	mcd	I <sub>F</sub> =20mA
Viewing Angle	2θ <sub>1/2</sub>	-----	130	-----	deg	I <sub>F</sub> =20mA
Peak Wavelength	λ <sub>p</sub>	-----	561	-----	nm	I <sub>F</sub> =20mA
Dominant Wavelength	λ <sub>d</sub>	557	-----	564	nm	I <sub>F</sub> =20mA
Spectrum Radiation Bandwidth	Δλ	-----	20	-----	nm	I <sub>F</sub> =20mA
Forward Voltage	V <sub>F</sub>	1.70	-----	2.30	V	I <sub>F</sub> =20mA
Reverse Current	I <sub>R</sub>	-----	-----	10	μA	V <sub>R</sub> =12V
Temperature coefficient of λ <sub>p</sub>	TC <sub>λ<sub>p</sub></sub>	-----	0.06	-----	nm/K	I <sub>F</sub> =20mA
Temperature coefficient of λ <sub>d</sub>	TC <sub>λ<sub>d</sub></sub>	-----	0.4	-----	nm/K	I <sub>F</sub> =20mA
Temperature coefficient of V <sub>F</sub>	TC <sub>V</sub>	-----	-2.3	-----	mV/K	I <sub>F</sub> =20mA

Note:

- 1.Tolerance of Luminous Intensity: ±11%
- 2.Tolerance of Dominant Wavelength ±1nm
- 3.Tolerance of Forward Voltage: ±0.05V
- 4.Reverse Voltage(VR) Condition is applied to IR test only The device is not designed for reverse operation

## Bin Range of Luminous Intensity

Bin Code	Min.	Max.	Unit	Condition
L1	11.20	14.00	mcd	I <sub>F</sub> =20mA
L2	14.00	18.00		
M1	18.00	22.40		
M2	22.40	28.00		

Note: Tolerance of Luminous Intensity: ±11%

## Bin Range of Dominant Wavelength

Bin Code	Min.	Max.	Unit	Condition
1	557	561	nm	I <sub>F</sub> =20mA
2	561	564		

Note: Tolerance of Dominant Wavelength: ±1nm

## Typical Electro-Optical Characteristics Curves

### Typical Curve of Spectral Distribution

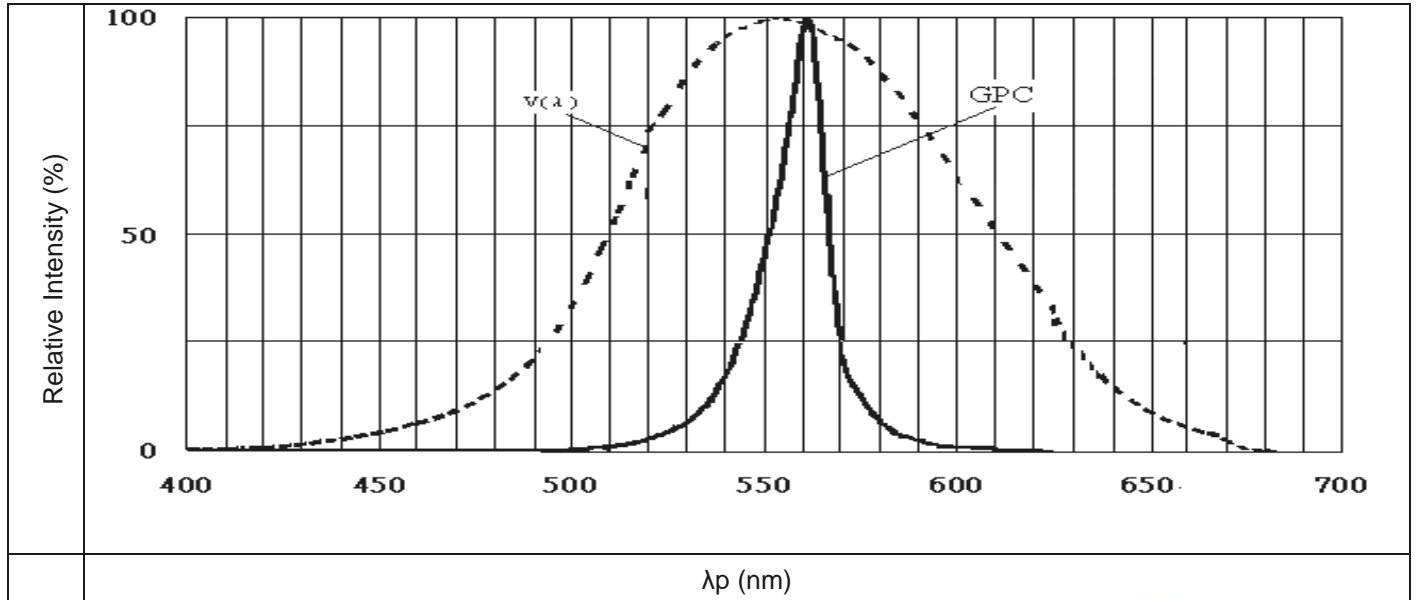

Note:  $V(\lambda)$ =Standard eye response curve;  $I_F = 20\text{mA}$

### Diagram Characteristics of Radiation

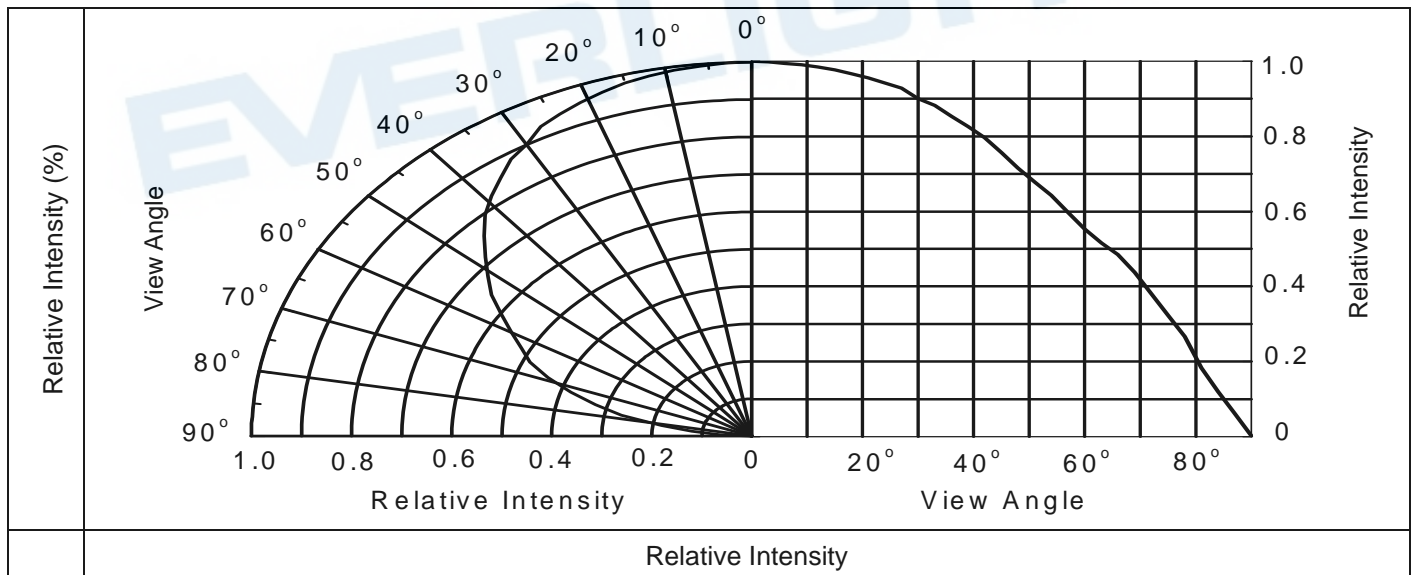

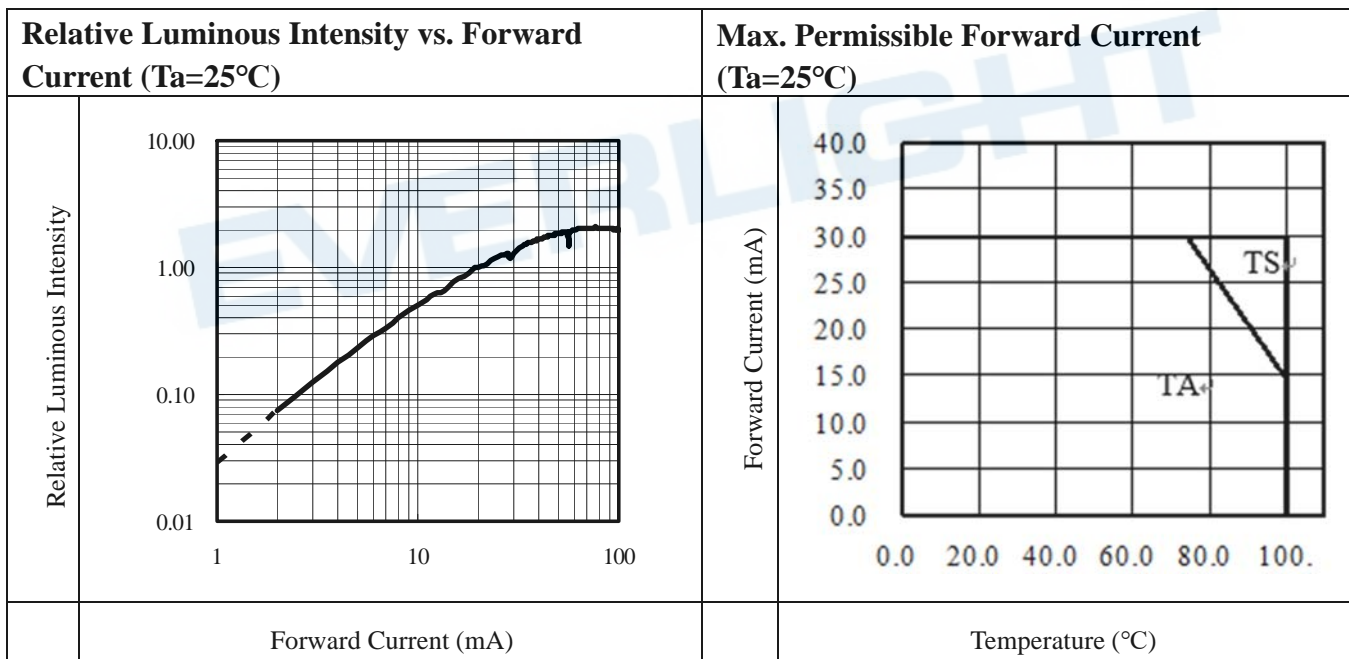
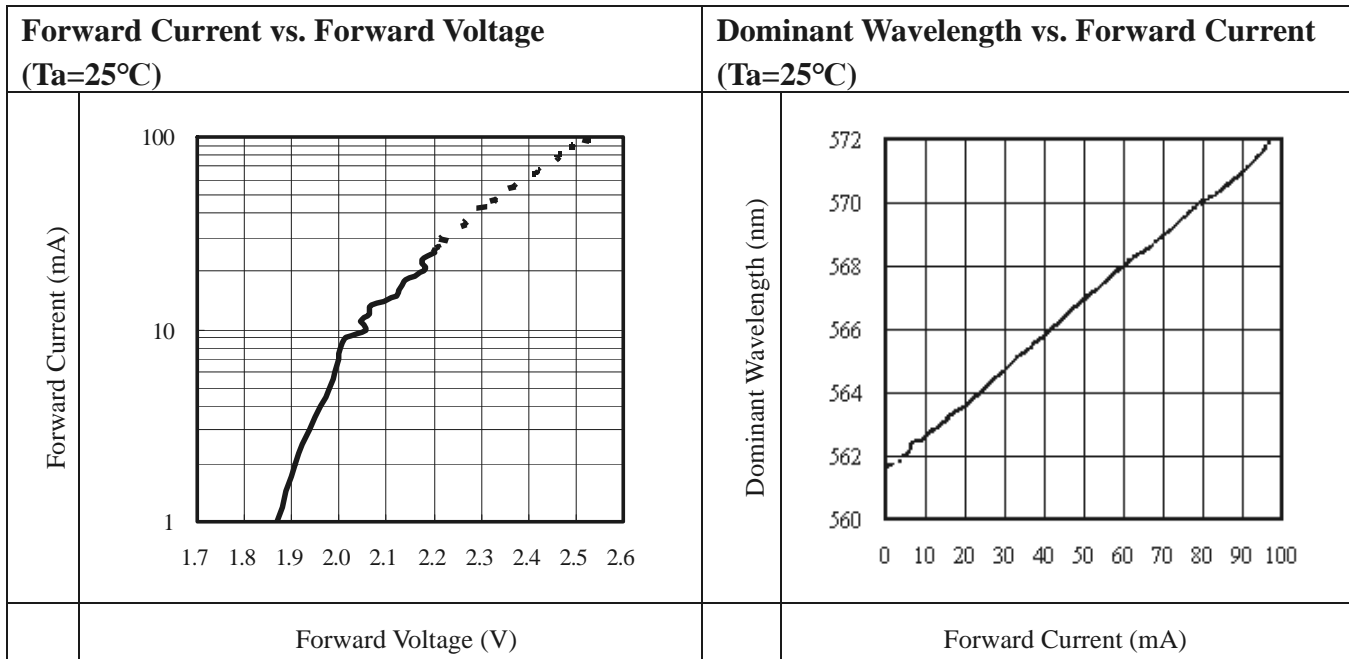

Relative Luminous Intensity vs. Junction Temperature		Relative Forward Voltage vs. Junction Temperature	
Relative Luminous Intensity		Relative Forward Voltage	
	Junction Temperature (°C)		Junction Temperature (°C)
Note: $f(T_j) = I_v / I_v(25^\circ\text{C})$ ; $I_F = 20\text{mA}$		Note: $\Delta V_F = V_F - V_F(25^\circ\text{C}) = f(T_j)$ ; $I_F = 20\text{mA}$	

Note: The graphs shown in this datasheet are representing typical data only and do not show guaranteed values.

EVERLIGHT

### Package Dimension

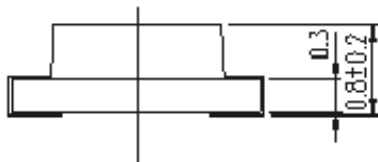
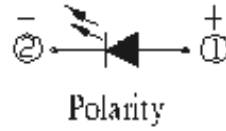
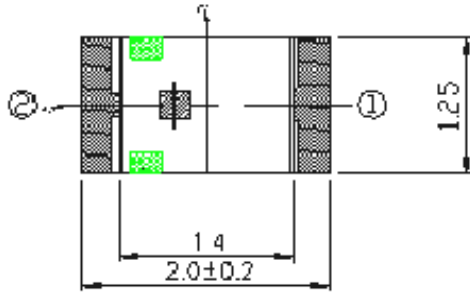

Recommend Soldering Pad

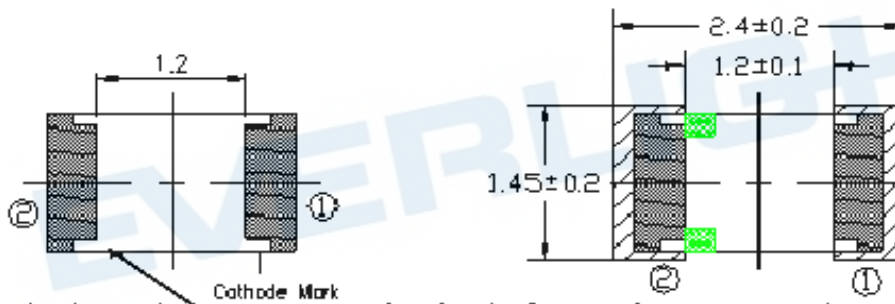

Suggested pad dimension is just for reference only.  
Please modify the pad dimension based on individual need.

Note: Tolerances unless mentioned  $\pm 0.1$ mm. Unit = mm

Moisture Resistant Packing Materials

Label Explanation

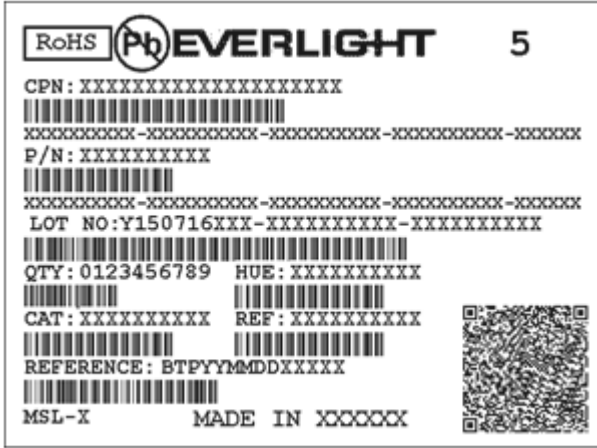

- .CPN: Customer's Product Number
- .P/N: Product Number
- .QTY: Packing Quantity
- .CAT: Luminous Intensity Rank
- .HUE: Dom. Wavelength Rank
- .REF: Forward Voltage Rank
- .LOT No: Lot Number

Reel Dimensions

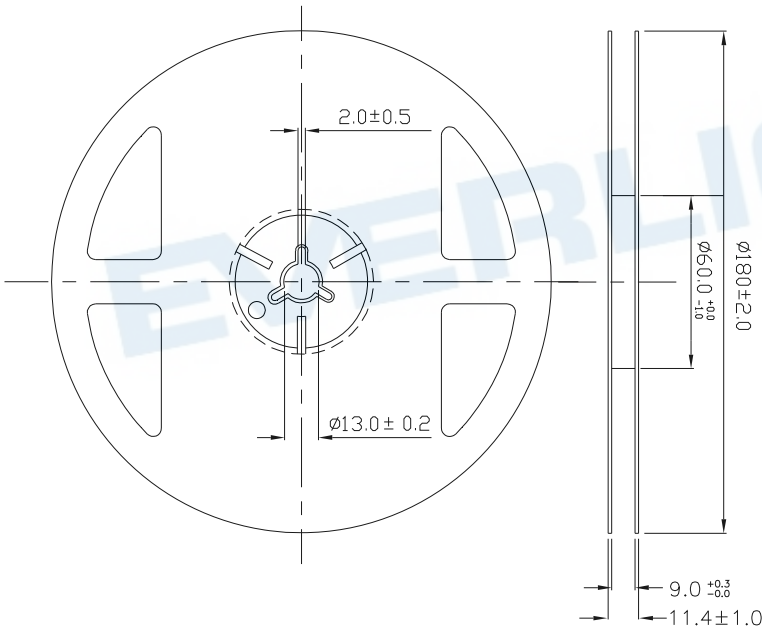

Note: The tolerances unless mentioned is  $\pm 0.1\text{mm}$  ,Unit = mm

**Carrier Tape Dimensions: Loaded Quantity 3000 pcs Per Reel**

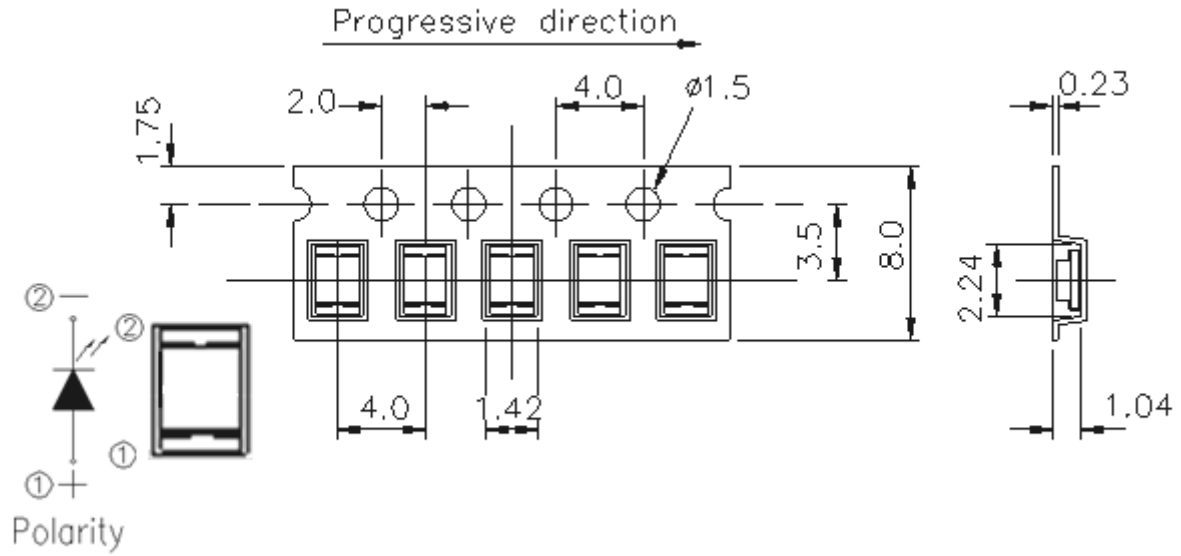

Note: Tolerances unless mentioned  $\pm 0.1\text{mm}$ . Unit = mm

**Moisture Resistant Packing Process**

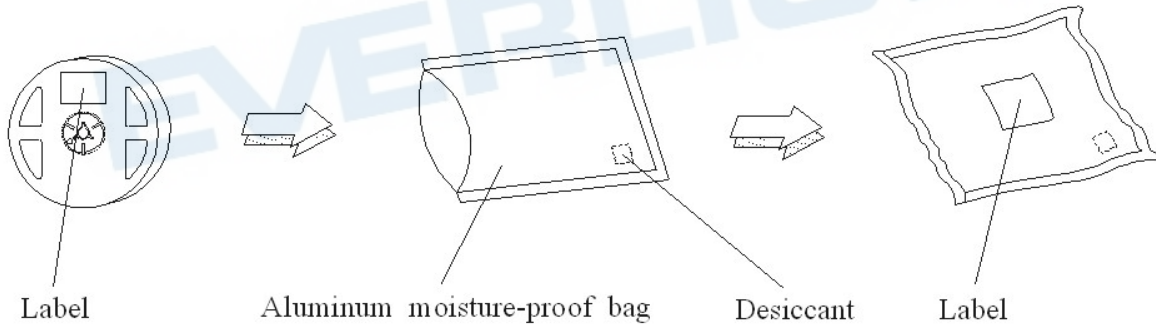

Note: Tolerances unless mentioned  $\pm 0.1\text{mm}$ . Unit = mm

**Precautions for Use**

**1. Soldering Condition (Reference: IPC/JEDEC J-STD-020D)**

**a. IR reflow**

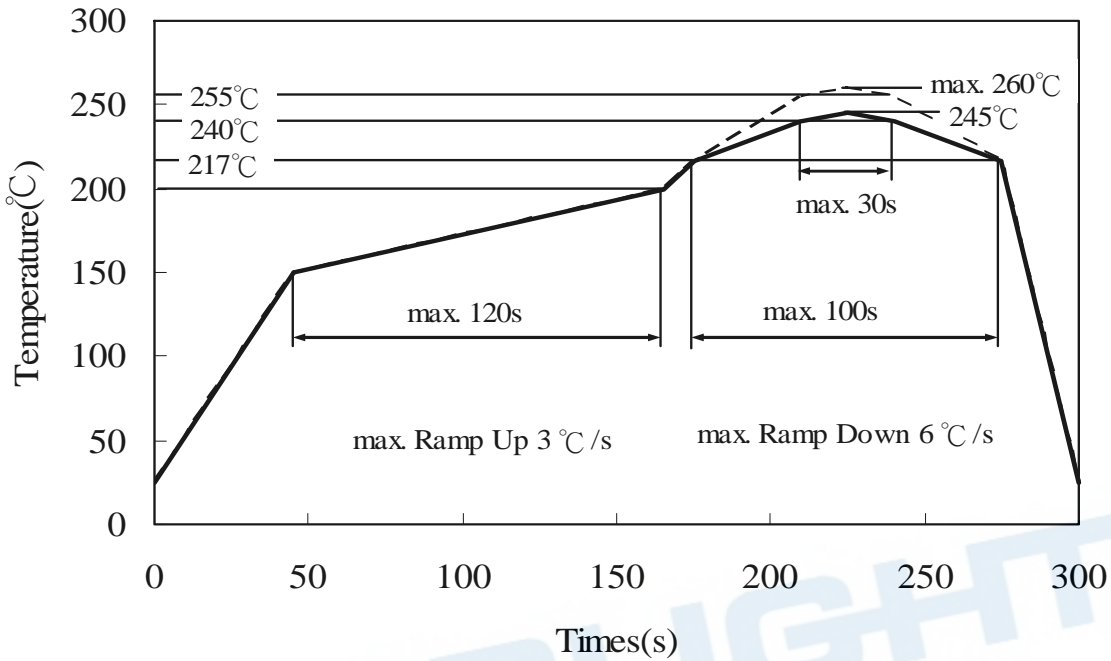

**b. Wave soldering reflow**

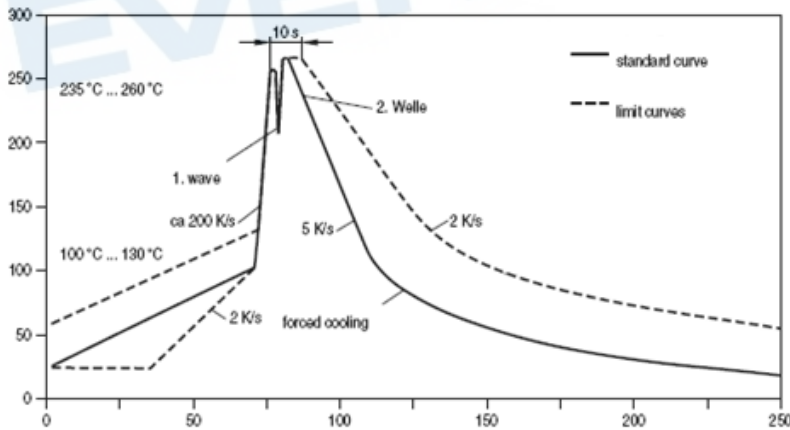

(B) Recommend soldering pad

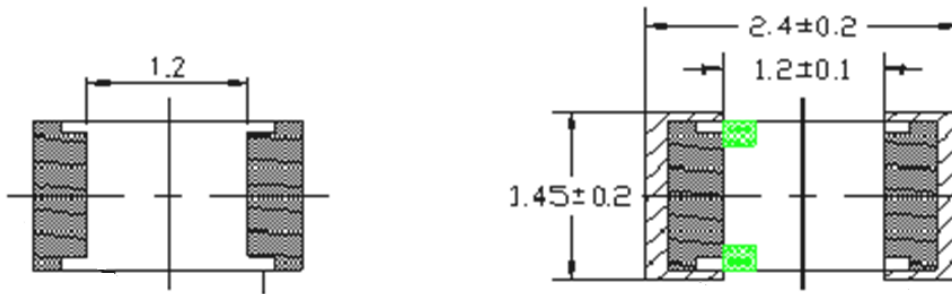

Note: Tolerances unless mentioned  $\pm 0.1$ mm. Unit = mm

## 2. Current limiting

A resistor should be used to limit current spikes that can be caused by voltage fluctuations. Otherwise damage could occur.

## 3. Storage

3.1 Moisture proof bag should only be opened immediately prior to usage.

3.2 Environment should be less than  $30^{\circ}\text{C}$  and 60% RH when moisture proof bag is opened.

3.3 After opening the package MSL Conditions stated on page 1 of this spec should not be exceeded.

3.4 If the moisture sensitivity card indicates higher than acceptable moisture, the component should be baked at min.  $60^{\circ}\text{deg}$   $\pm 5^{\circ}\text{deg}$  for 24 hours.

## 4. Soldering Iron

Each terminal is to go to the tip of soldering iron temperature less than  $350^{\circ}\text{C}$  for 3 seconds. Leave two seconds and more intervals, and do soldering of each terminal. Be careful because the damage of the product is often started at the time of the hand solder.

## 5. Usage

Do not exceed the values given in this specification.

## Application Restrictions

High reliability applications such as military/aerospace, automotive safety/security systems, and medical equipment may require different product. If you have any concerns, please contact Everlight before using this product in your application. This specification guarantees the quality and performance of the product as an individual component. Do not use this product beyond the specification described in this document.

EVERLIGHT

## DISCLAIMER

1. EVERLIGHT reserves the right(s) on the adjustment of product material mix for the specification.
2. The product meets EVERLIGHT published specification for a period of twelve (12) months from date of shipment.
3. The graphs shown in this datasheet are representing typical data only and do not show guaranteed values.
4. When using this product, please observe the absolute maximum ratings and the instructions for using outlined in these specification sheets. EVERLIGHT assumes no responsibility for any damage resulting from the use of the product which does not comply with the absolute maximum ratings and the instructions included in these specification sheets.
5. These specification sheets include materials protected under copyright of EVERLIGHT. Reproduction in any form is prohibited without obtaining EVERLIGHT's prior consent.
6. This product is not intended to be used for military, aircraft,, medical, life sustaining or life saving applications or any other application which can result in human injury or death. Please contact authorized Everlight sales agent for special application request.

## Revision History:

Rev.	Modified date	File modified contents
1	2009/8/18	New Spec
2	2024/5/4	Add 6 affirmations